

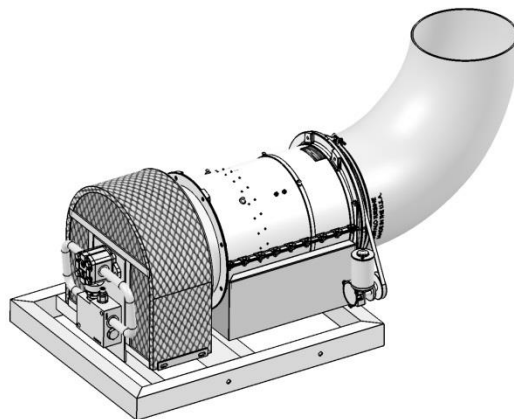

Buffalo Turbine LLC  
180 Zoar Valley Road  
Springville, NY 14141  
Tel: 716-592-2700  
Fax: 716-592-2460

## Hydraulic Debris Blower Model # BT-HY3



Warranty	One Year Buffalo Turbine Warranty
Motor Warranty	1 Year Warranty
Input Power:	Hydraulic motor
Input RPM:	Up to 3600 RPM*
Outlet Size:	12"
Frame Length	39"
Overall Length with Nozzle	64"
Width:	46"
Max Height with nozzle in upright position	32"
Weight:	300 lbs
Nozzle Rotation:	360 Degrees
Hydraulic Motor Displacement size	.915 cu.in./Rev
Required minimum hydraulic pressure (to operate @ stated values)	2900 psi
Maximum Hydraulic flow rate	25 GPM
Mounting (any position)	SAE "A" size, 2 bolt
Shaft Seal Max. Pressure	250 psi
Port location	Side ports

(\* Flow Rates below 16 gpm will reduce the Blower output (RPM) please contact Buffalo Turbine for More information.

\*\*It is necessary to warm up the hydraulic vehicle for 5 minutes to get the hydraulic oil up to operating temperature\*\*