

KDI 3404 TCR - SCR

OWNER MANUAL



KOHLER[®]
IN POWER. SINCE 1920.

REGISTRATION OF MODIFICATIONS TO THE DOCUMENT

Any modifications to this document must be registered by the drafting body, by completing the following table.

Released by	Document code	Model N°	Edition	Revision	Issue date	Review date	Edited by	Endorsed
Technical Documentation	ED0053032140	51534	01	00	06/2017	11/2017	Technical Documentation	

Translated from the original manual in Italian language.

Data reported in this issue can be modified at any time by KOHLER.



Important

Connect to <http://iservice.lombardini.it> > **KDI KOHLER DIESEL** section > login as a guest "**Enter as a guest**" > "**TECHNICAL DOCUMENTATION**" > select "**KDI 3404 TCR-SCR**" and download the latest version of this manual onto your device.

NOTE: you can select the desired language before downloading the manual, as shown in the figure below.

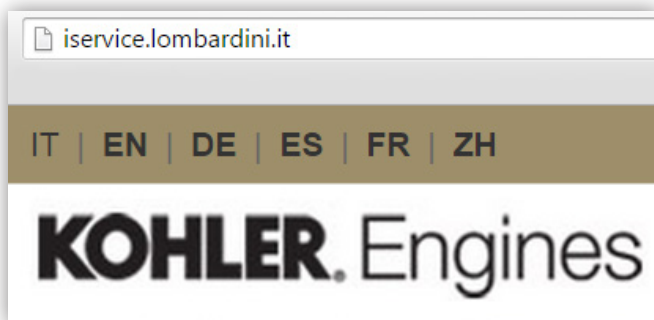

The online manuals are provided with hyperlinks which direct you to each individual chapter. By clicking on;

- The analytic index titles you can go directly to the selected subject.
- The blue underlined words you can go directly to a paragraph, a table or a picture.
- The chapter titles (headings) you come back automatically to the chapter initial page.
- Clicking next to the bottom page number you come back to the analytic index.

1 - GENERAL INFORMATION

1.1 Manual's Purpose.....	6
1.2 Glossary and Definitions.....	6
1.3 Emission-Related Installation Instructions.....	6
1.4 Service request.....	6
1.5 Manufacturer and engine identification.....	7
1.6 Engine component identification.....	8
1.7 Cooling circuit.....	10
1.8 AdBlue circuit.....	11
1.9 Intake and exhaust circuit.....	12
1.10 Homologation labels.....	13
1.10.1 Label for EPA rules.....	13
1.10.2 Label for China Standards.....	14
1.10.3 Label for Korea Standards.....	15

2 - TECHNICAL INFORMATION

2.1 General description of the engine.....	16
2.2 Engine specifications.....	16
2.3 Engine dimensions (mm).....	16
2.4 Oil.....	17
2.5 Fuel.....	18
2.5.1 Fuel for low temperatures.....	19
2.5.2 Biodiesel fuel.....	19
2.5.3 Synthetic fuels: GTL, CTL, BTL, HV.....	19
2.5.4 Emission-Related Installation Instructions.....	19
2.6 AdBlue.....	20
2.7 Coolant recommendation.....	21
2.8 Battery recommendation.....	21
2.9 Inducement strategy of SCR system.....	22

3 - SAFETY INFORMATION

3.1 Safety information.....	24
3.2 General remarks.....	24
3.2.1 Note for OEM.....	24
3.2.2 Note for end user.....	24
3.3 Safety signal description.....	26
3.3.1 Adhesive safety plates.....	26
3.3.3 Warnings.....	26
3.3.2 Safety guards.....	26
3.4 Information and safety signals.....	27
3.5 Safety and environmental impact.....	27
3.6 Location of safety labels on engine.....	28

4 - INFORMATION ABOUT USE

4.1 Pre-start check.....	29
4.2 Running-in period.....	29
4.3 Starting and turning off.....	29
4.3.1 Starting.....	29
4.3.2 After starting.....	29
4.3.3 Turning off.....	29
4.4 Refuelling.....	30
4.5 Oil filling.....	30
4.6 Coolant filling.....	31
4.7 AdBlue® filling.....	31

5 - INFORMATION ABOUT MAINTENANCE

5.1 Useful information about maintenance.....	32
5.2 Periodic maintenance.....	32
5.3 Oil level check.....	33
5.4 Air filter check.....	33
5.5 5.5 Check of the radiator heat - exchanger surface.....	34
5.6 Rubber hoses check.....	34
5.7 Check coolant level.....	34
5.8 Check Poly-V alternator belt.....	35
5.9 Filter cartridge and fuel pre-filter check.....	35
5.10 Product preservation.....	36
5.11 Engine storage up to 6 months.....	36
5.12 Engine storage over 6 months.....	36
5.13 Engine starting after storage.....	36

6 - INFORMATION ABOUT REPLACEMENTS

6.1 Engine oil replacement.....	37
6.2 Oil filter cartridge replacement.....	38
6.3 Filter cartridge and fuel pre-filter check.....	39
6.4 Air filter cartridge replacement.....	39
6.5 Disposal and scrapping.....	40

7 - INFORMATION ABOUT FAILURES

7.1 Useful information about failures.....	41
--	----

8- INFORMATION ABOUT WARRANTY

8.1 Info.....	42
---------------	----

9- GLOSSARY

Glossary.....	45
Symbols and units of measurement.....	47

1.1 Manual's purpose

- This manual contains the instructions needed to carry out proper use and maintenance of the engine, therefore it must always be available, for future reference when required.
- This manual is an integral part of the engine, in the event of transfer or sale, it must be attached to it.
- Safety pictograms can be found on the engine and it is the operator's responsibility to keep them in a perfectly visible place and replace them when they are no longer legible.
- Information, description and pictures in this manual reflect the state of the art at the time of the marketing of engine.
- However, development on the engines is continuous. Therefore, the information within this manual is subject to change without notice and without obligation.
- KOHLER reserves the right to make, at any time, changes in the engines for technical or commercial reasons.
- These changes do not require KOHLER to intervene on the marketed production up to that time and not to consider this manual as inappropriate.
- Any additional section that KOHLER will deem necessary to supply some time after the main text shall be kept together with the manual and considered as an integral part of it.
- The information contained within this manual is the sole property of KOHLER. As such, no reproduction or replication in whole or part is allowed without the express written permission of KOHLER.

1.2 Glossary and Definitions

The paragraphs, tables and figure are divided into chapter with their progressive numbers.

- Ex: Par. 2.3 - chapter 2 paragraph 3.
Tab. 3.4 - chapter 3 table 4.
Fig. 5.5 - chapter 5 figure 5.

The references of the objects described in the text and in figure and number are indicated by letters, which are always and only related to the paragraph you are reading unless there are specific references to other figures or paragraphs.

NOTE: *All data, measurements and relevant symbols are shown in the glossary section.*

1.3 Emission-Related Installation Instructions

Failing to follow the instructions in the applications guidebook when installing a certified engine in a piece of nonroad equipment violates federal law (40 CFR 1068.105(b)), subject to fines or other penalties as described in the Clean Air Act.

OEM must apply a separate label with the following statement: "ULTRA LOW SULFUR FUEL ONLY" near the fuel inlet.

Ensure you are installing an engine appropriately certified for your application. Constant speed engines may only be installed on constant speed equipment for constant speed operation.

If you install the engine in a way that makes the engine's emission control information label hard to read during normal engine maintenance, you must place a duplicate label on the equipment, as described in 40 CFR 1068.105.

1.4 Service request

- The complete and updated list of authorized Kohler Co. service centers can be found on websites: www.kohlerengines.com & www.lombardinigroup.it/dealer-locator.
- If you have any questions regarding your warranty rights and responsibilities or the location of the nearest Kohler Co. authorized service location, you should contact Kohler Co. at 1-800-544-2444 or access our website at www.kohlerengines.com (USA and North American).

1.5 Manufacturer and motor identification data

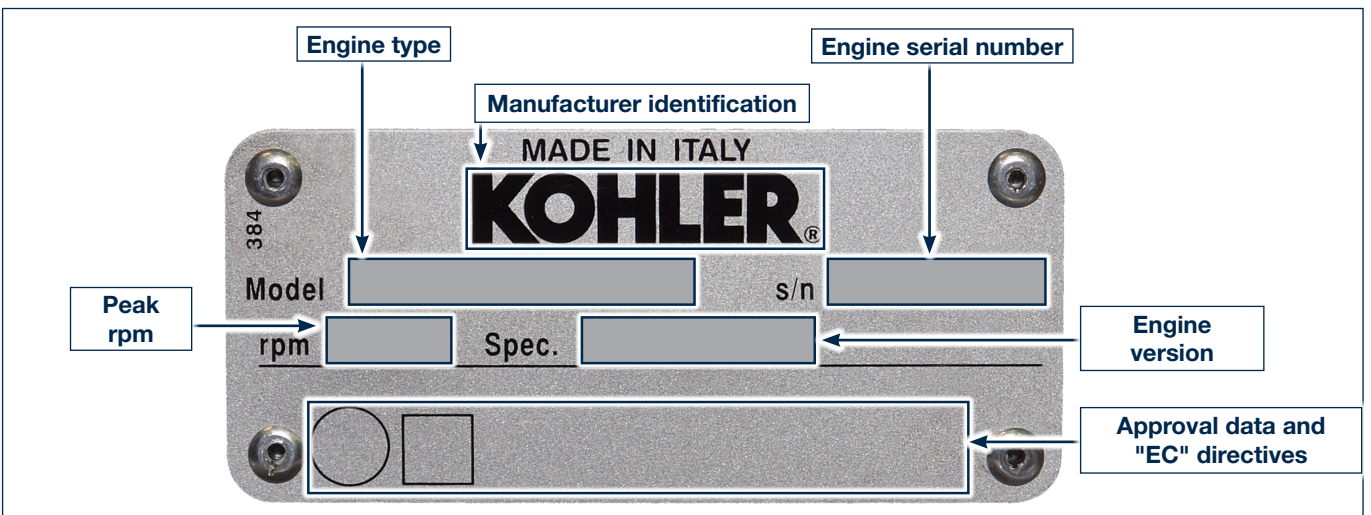
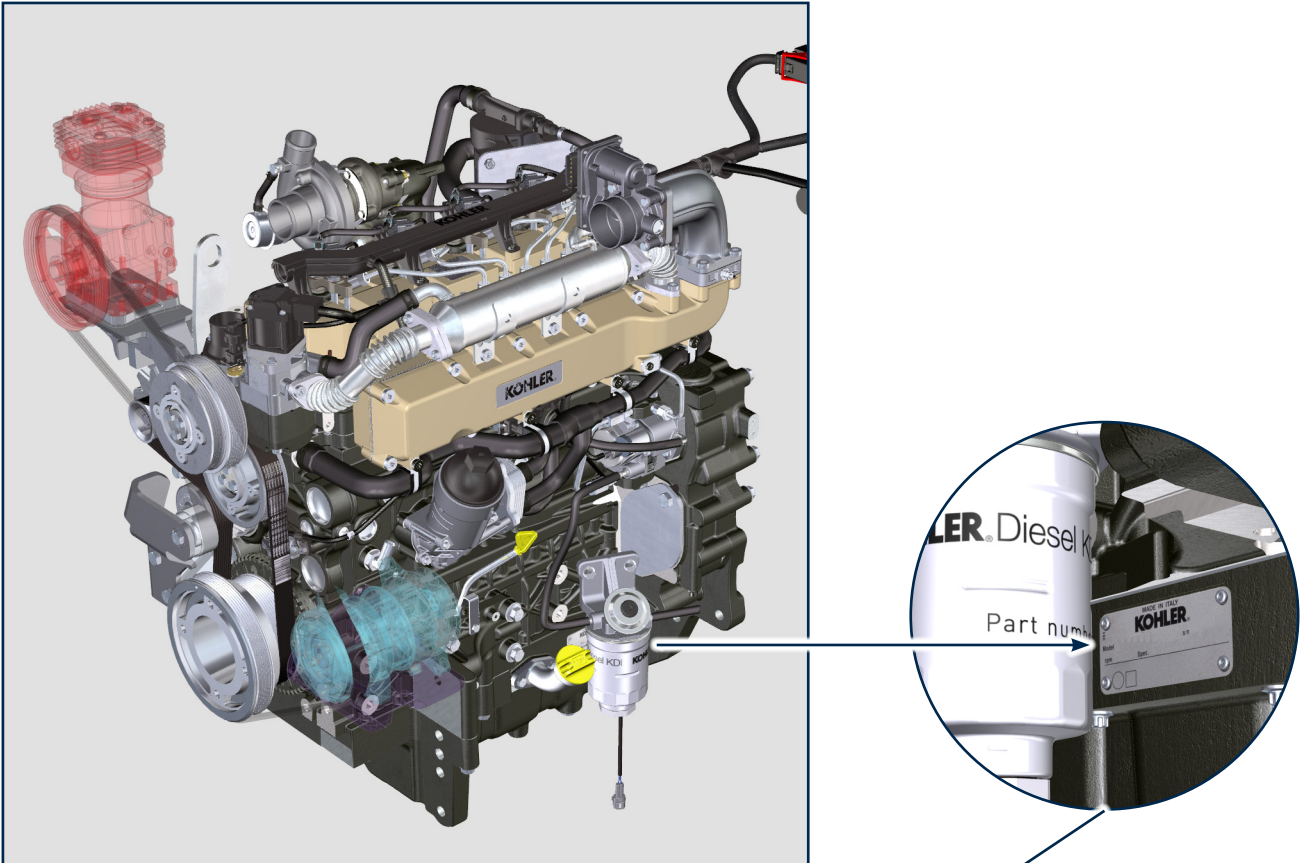

1.6 Engine component identification

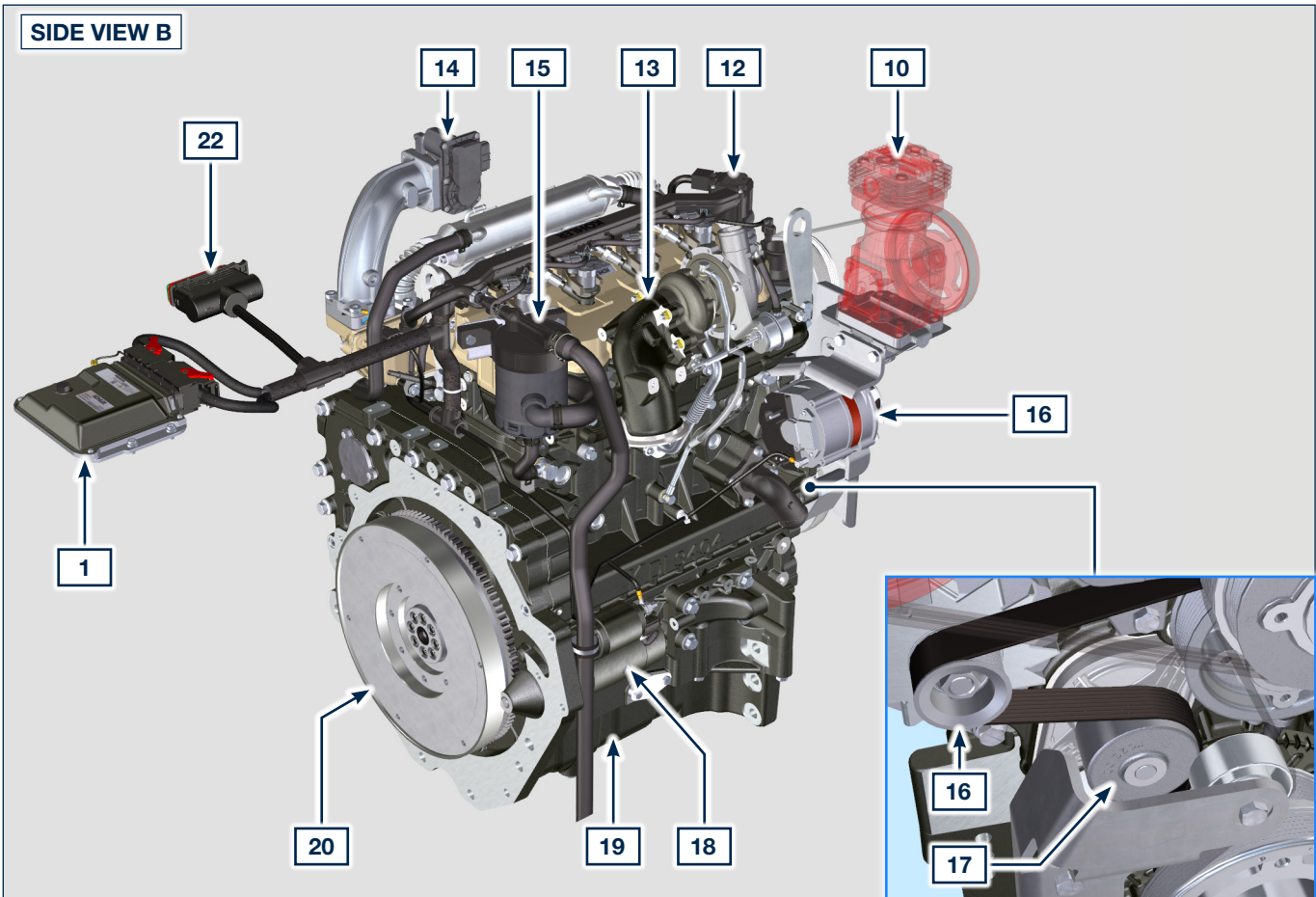
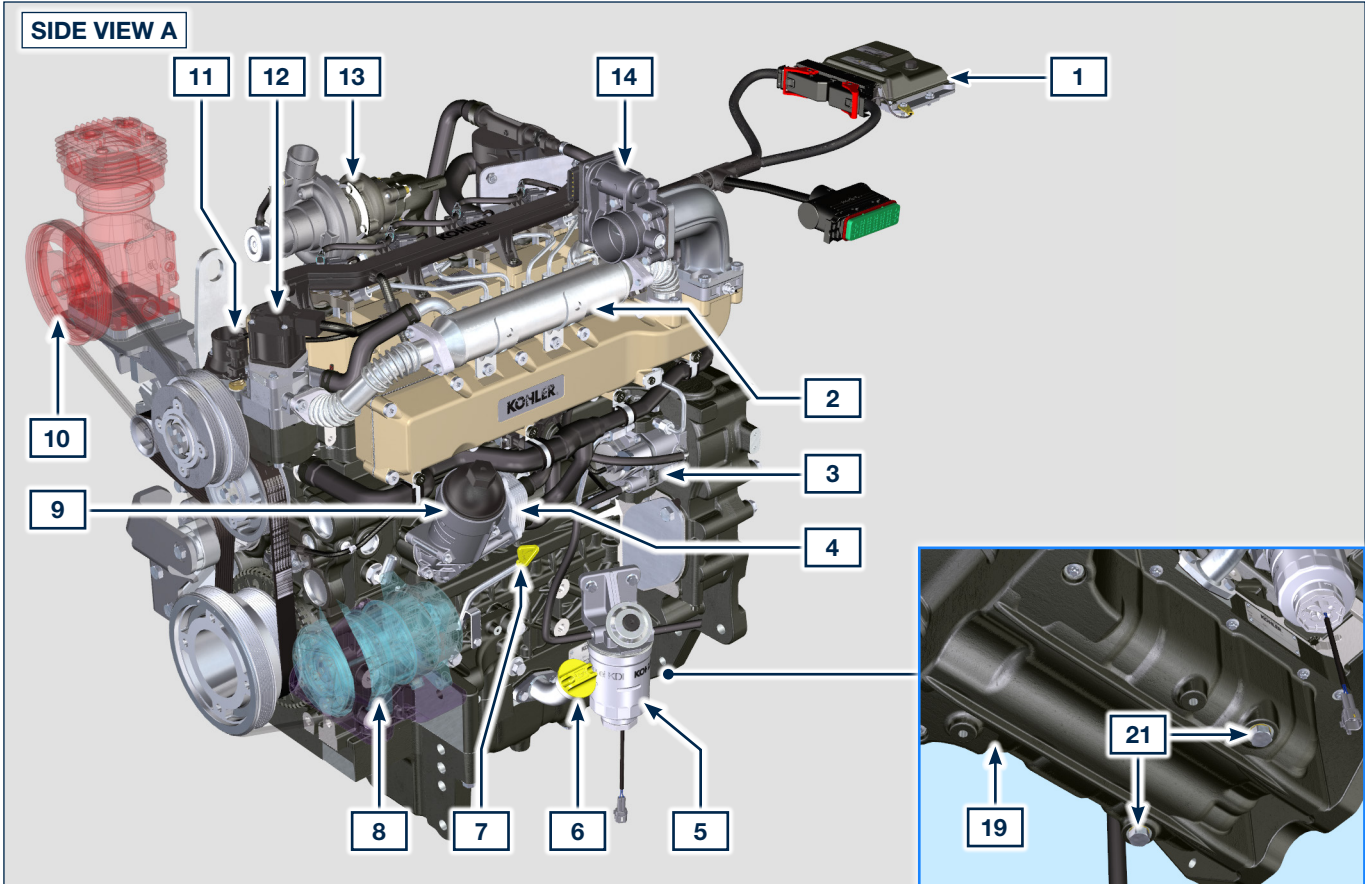

1.1	POS.	DESCRIPTION
	1	ECU
	2	EGR Cooler
	3	High-pressure fuel injection pump
	4	Oil cooler
	5	Fuel filter
	6	Oil filler side cap
	7	Oil dipstick
	8	AC compressor
	9	Lub. oil filter
	10	Brake compressor
	11	Thermostatic valve
	12	EGR valve
	13	Turbocharger
	14	Air inlet valve
	15	Oil steam separator
	16	Alternator
	17	Coolant pump
	18	Starter motor
	19	Oil sump
	20	Flywheel
	21	Oil drain plug
	22	Wiring
	23	Oil filler cap

Some components are for illustrative purposes only and may vary.

NOTE: *Components in Pos. 8, 10 are not supplied by Kohler*

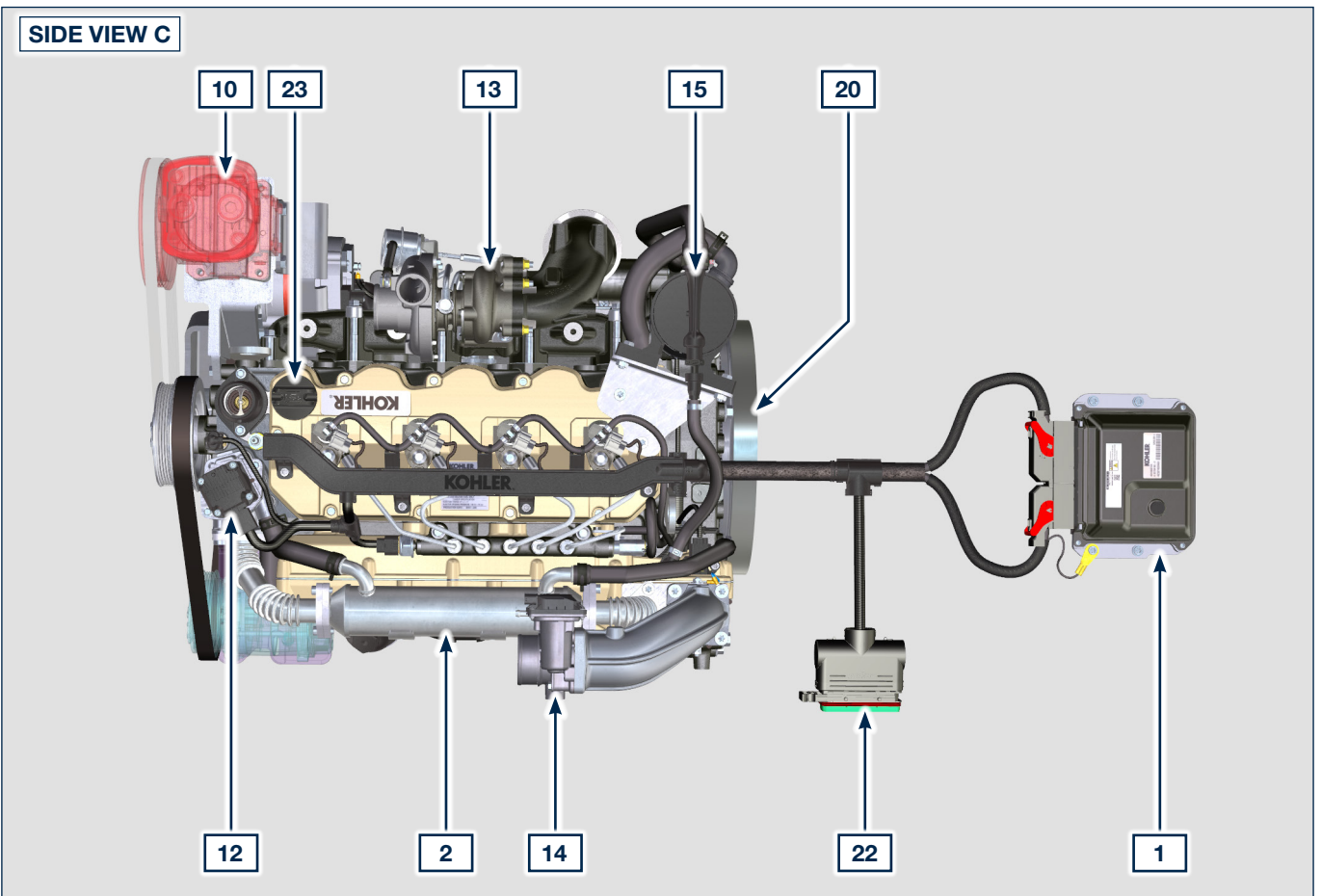

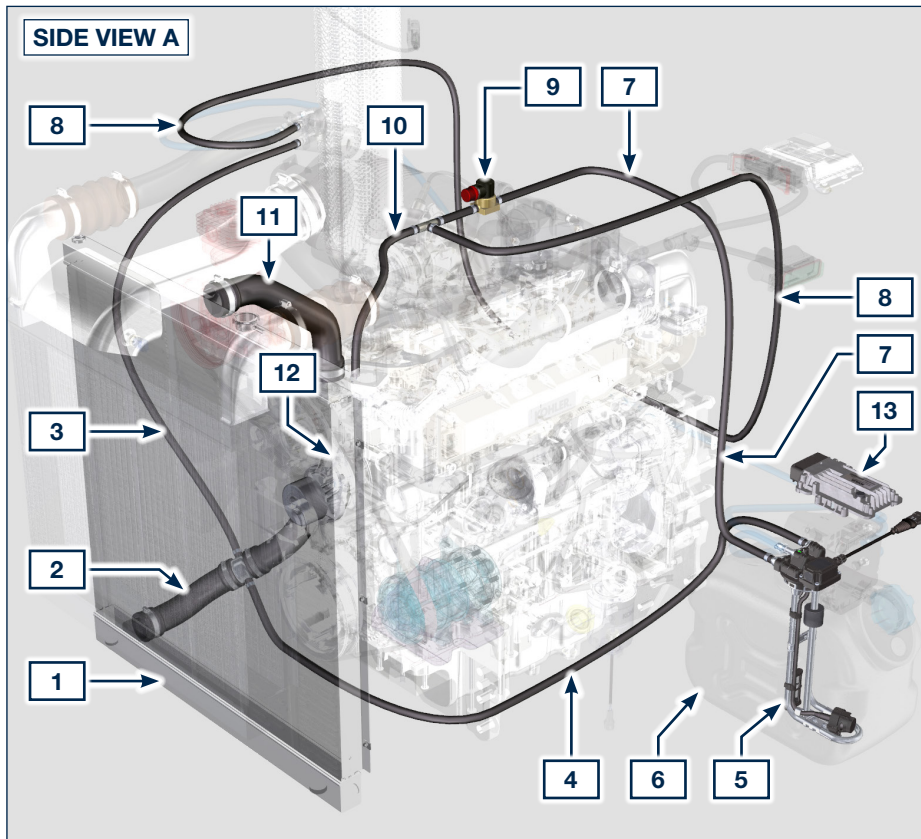
1.7 Cooling circuit

1.2

POS.	DESCRIPTION
1	Radiator
2	Intake sleeve
3	Intake return tube
4	Intake return tube
5	Circuit for AdBlue heating
6	AdBlue tank
7	Coolant delivery tube in AdBlue tank
8	Coolant delivery tube to AdBlue injector
9	Electronic valve for coolant delivery to AdBlue tank
10	Coolant delivery tube to SCR system
11	Coolant to radiator return sleeve
12	Coolant pump
13	SCR system control unit

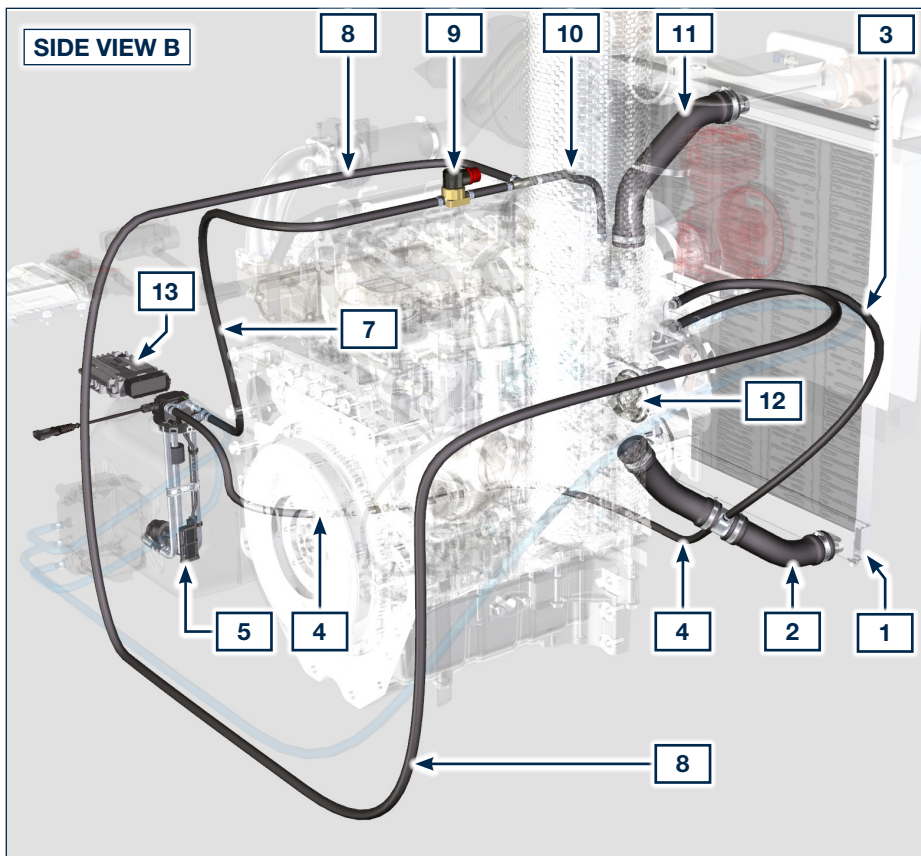

Some components are for illustrative purposes only and may vary.

NOTE: Components in Pos. 1, 2, 3, 4, 7, 8, 10, 11 are not supplied by Kohler

1.8 AdBlue circuit

1.3

POS.	DESCRIPTION
1	SCR system control unit
2	AdBlue tank
3	AdBlue pump
4	AdBlue intake tube
5	AdBlue delivery tube to AdBlue injector
6	Return tube in AdBlue tank
7	AdBlue injector

SIDE VIEW A

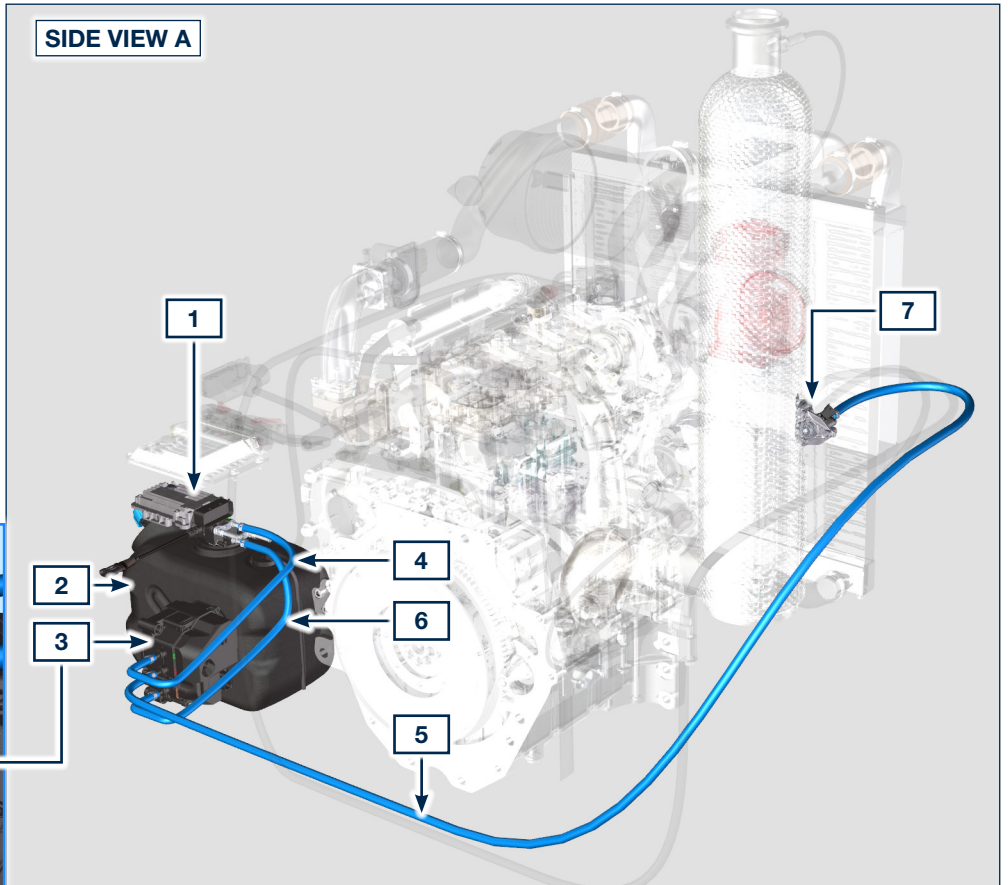
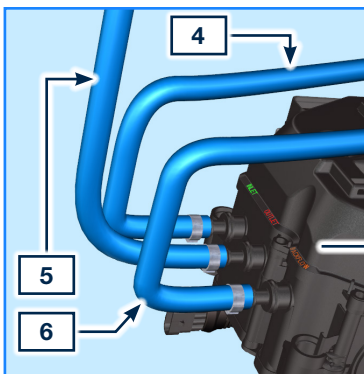

SIDE VIEW B

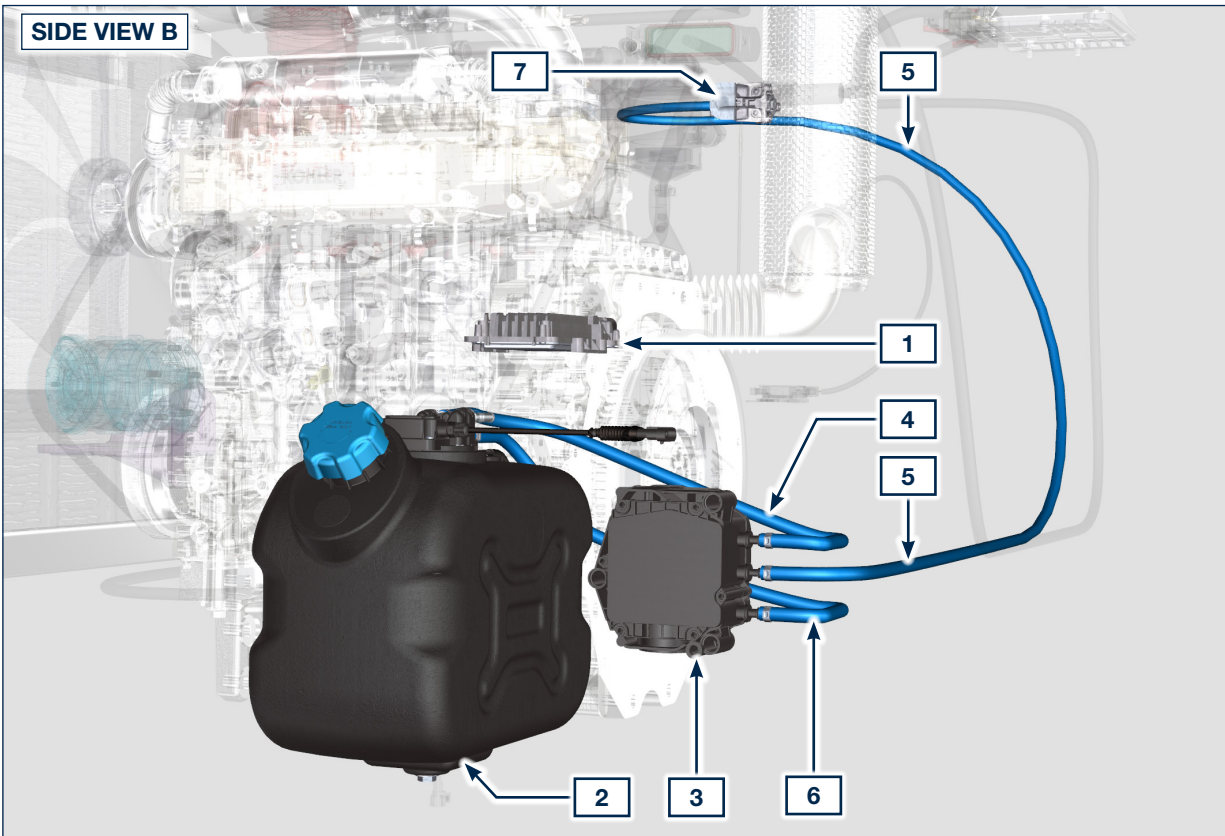

Some components are for illustrative purposes only and may vary.

NOTE: Components in Pos. 4, 5, 6 are not supplied by Kohler

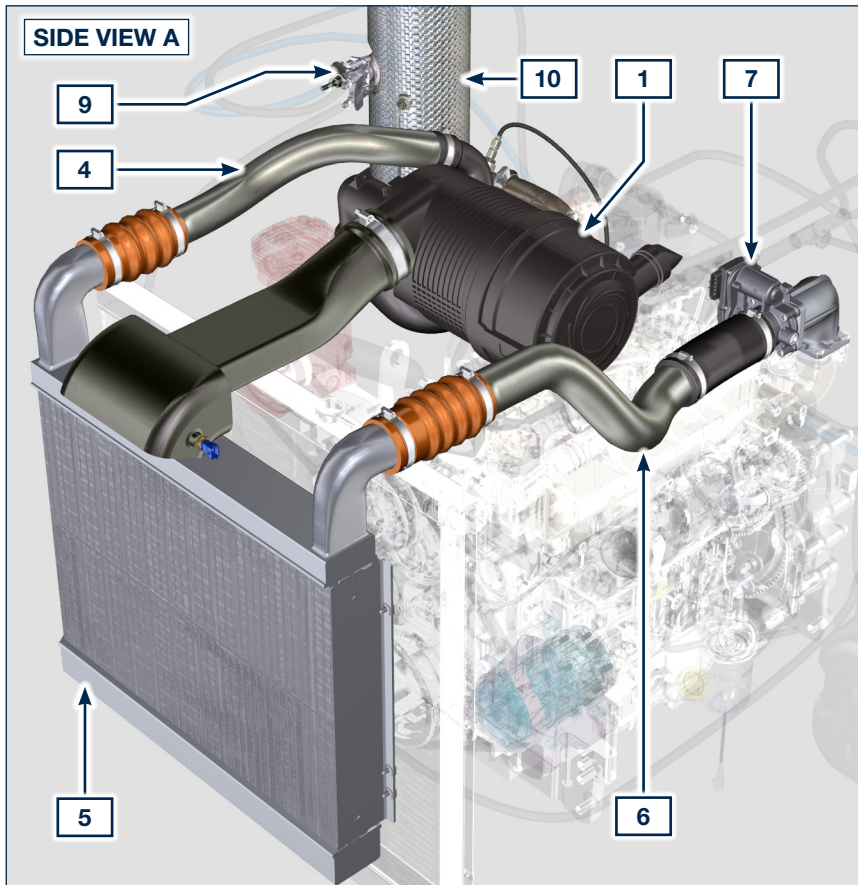
1.9 Intake and exhaust circuit

1.4

POS.	DESCRIPTION
1	Air filter
2	Air intake sleeve
3	Turbocharger
4	Air delivery tube to Intercooler
5	Intercooler
6	Air delivery tube to intake manifold
7	Air inlet valve
8	Exhaust gas delivery hose to SCR
9	AdBlue injector
10	SCR

Some components are for illustrative purposes only and may vary.

NOTE: *Components in Pos. 1, 2, 4, 5, 6 are not supplied by Kohler*

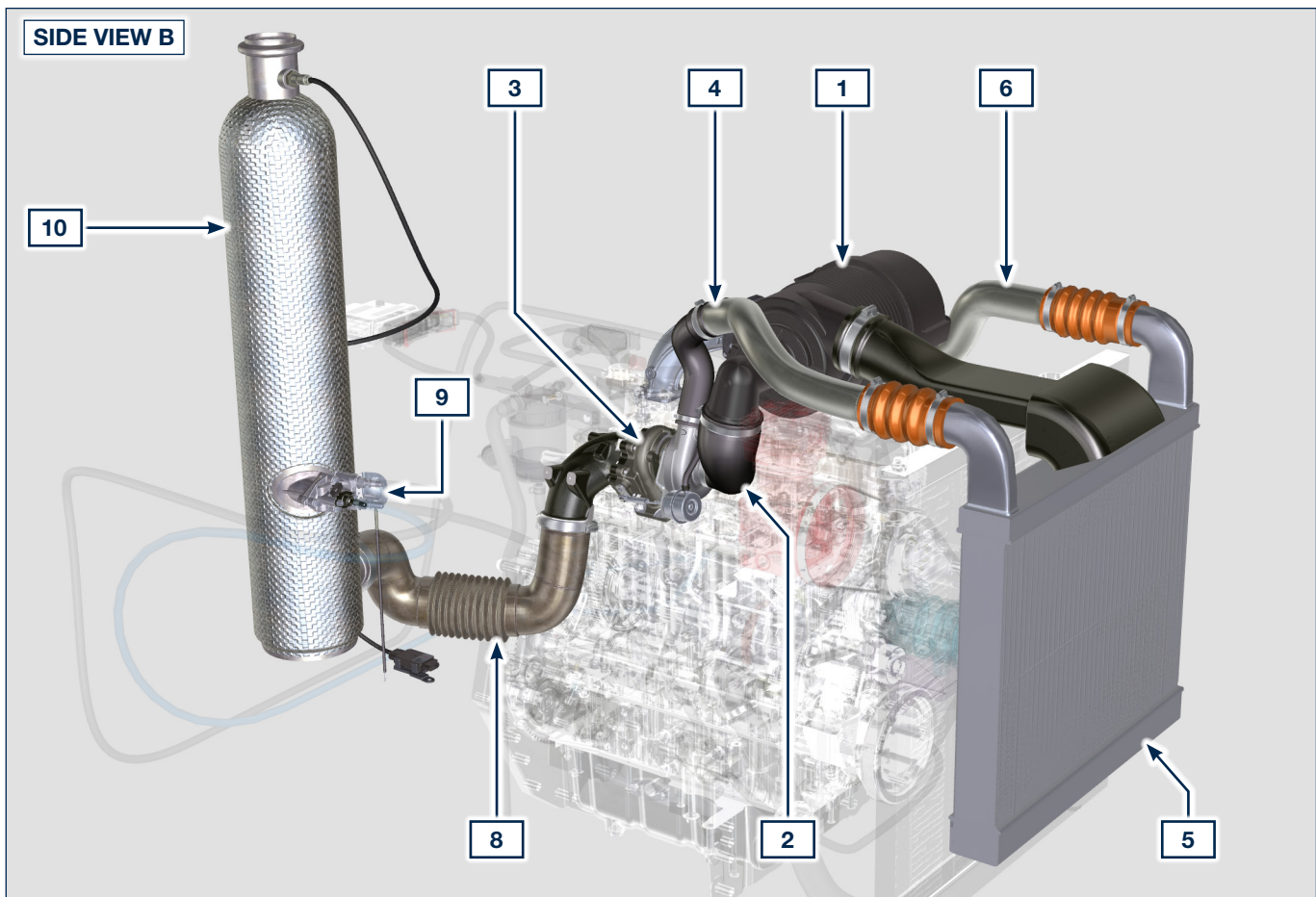

1.10 Homologation labels

1.10.1 Label for EPA rules

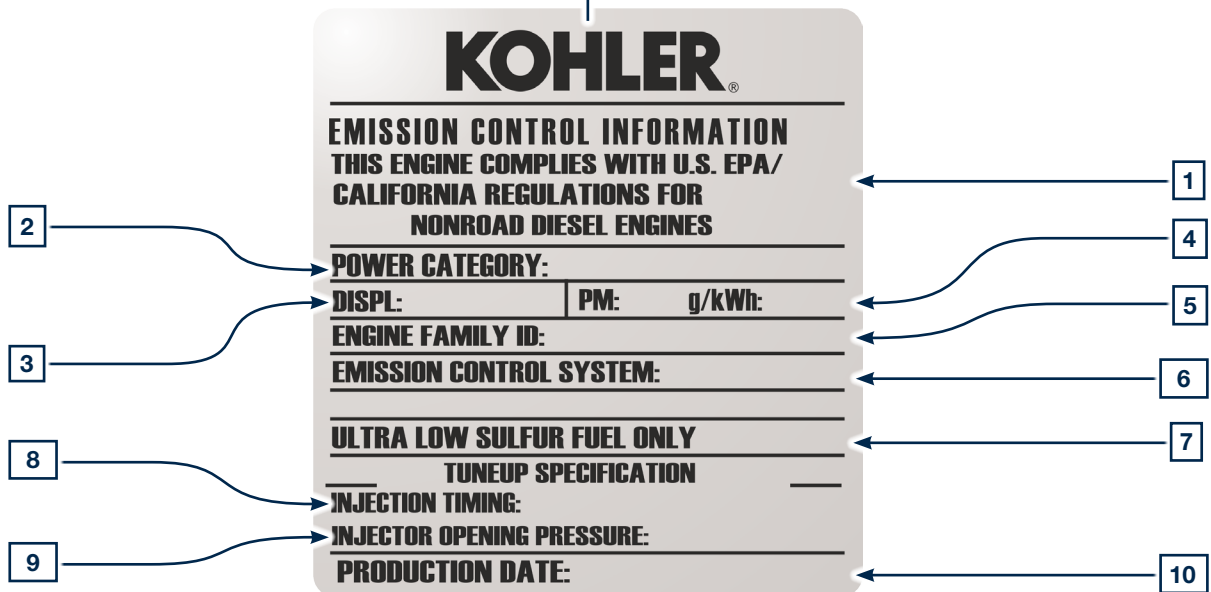
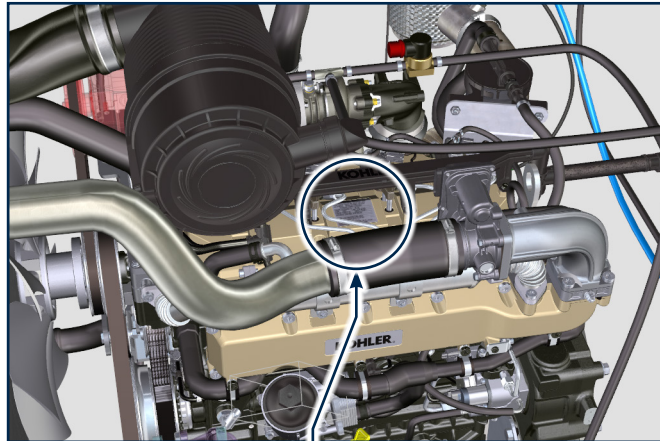

POS.	DESCRIPTION
1	Model year in compliance with the rules
2	Power category (kW)
3	Engine displacement (L)
4	Particulate emission limit (g/kWh)
5	Engine family ID
6	Emission Control System = ECS
7	Fuel with low sulphur content
8	Injection timing (*BTDC)
9	Injector opening pressure (bar)
10	Production date (example: 2013.JAN)

1.10.2 Label for China Standards

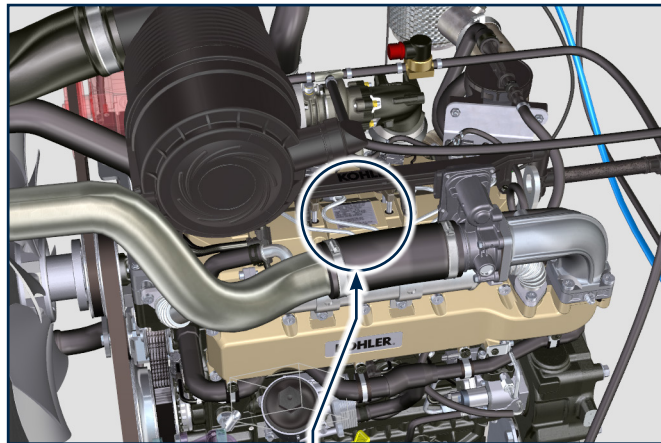

KOHLER®	
此发动机符合中国非道路移动式机械用柴油国3标准 This engine compliant with Stage 3 of China Off-road Mobile Machinery Standard GB20891-2014.	
1 → 制造商 \ Manufacturer	← 2 机型 \ Engine model
3 →	←
生产日期 \ Manufacturing date	
信息公开 \ Information Disclosure No. CN FC G3 00 0G92000005 000001	
5 →	← 4
← 6	← 6
7 →	← 8
所属功率范围 \ Power Range 75kW — 100kW	排放阶段 \ Emission Level 国3
额定功率 \ Rated Power 100.0kW/2200rpm	后处理系统 \ Aftertreat system 不适用

POS.	DESCRIPTION
1	Manufacturer
2	Engine model
3	Manufacturing date
4	Certificate N°
5	Power range (kW)
6	Emission level
7	Rated power
8	Aftertreat system

1.10.3 Label for Korea Standards

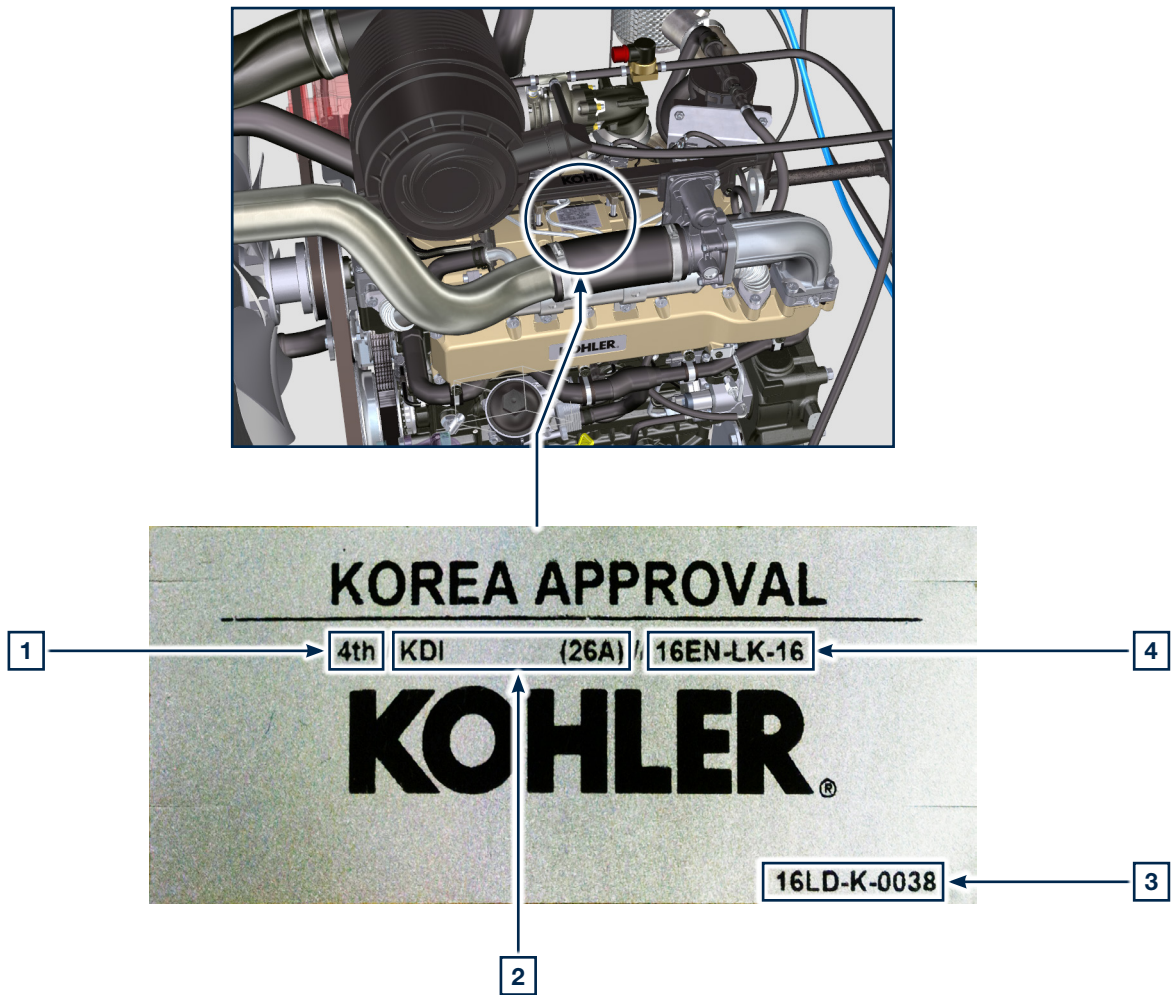

POS.	DESCRIPTION
1	Tier 4 Final
2	Engine model
3	Manufacturing date and manufacturer code
4	N° Korea emission certificate

2.1 General description of the engine

- 4-stroke, in-line cylinders Diesel engine;
- Liquid-cooling system;
- 4 valves per cylinder with hydraulic tappets;
- Turbocharger with Waste-gate valve;
- Common Rail - Direct injection.

2.2 Engine specifications

2.1

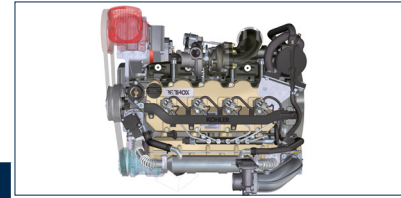

TECHNICAL DATA		UNIT OF MEASURE	KDI 340 TCR-SCR
ENGINE TYPE			KDI 340 TCR-SCR
CYLINDERS		n.	4
BORE		mm	96
STROKE		mm	116
DISPLACEMENT		cm ³	3359
MAX INCLINATION DURING OPERATION (even in combined)		α	40° max. 30 minutes
		α	45° max.1 minute
OIL CAPACITY (MAX LEVEL.) including oil filter	standard version	lt.	15.6
DRY WEIGHT		kg	394

2.3 Engine dimensions (mm)

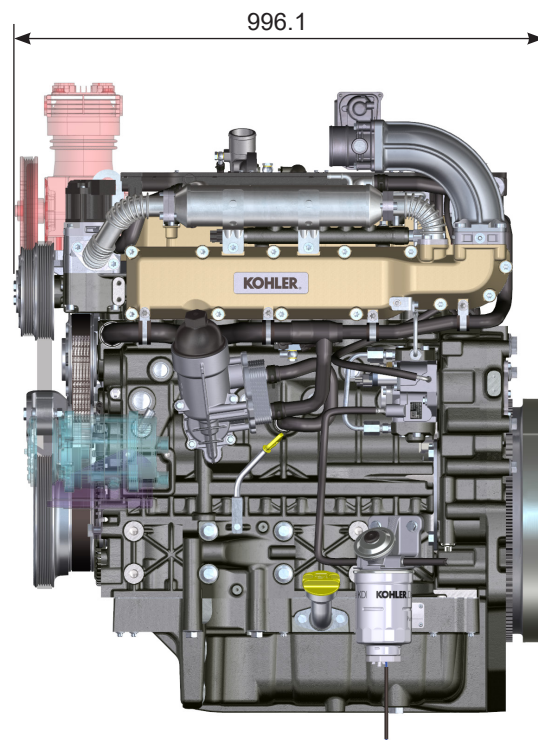
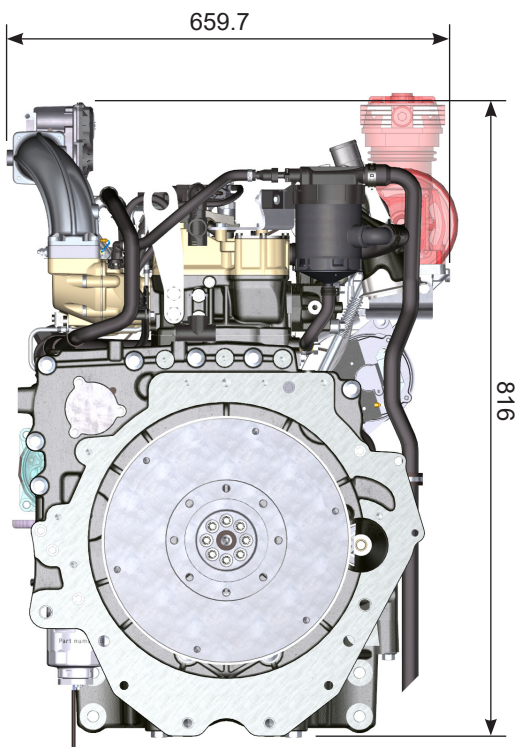

2.4 Oil



Important

- The engine may be damaged if operated with improper oil level.
- Do not exceed the MAX level because a sudden increase in engine rpm could be caused by its combustion.
- Use only the recommended oil to ensure adequate protection, efficiency and service life of the engine.
- The use of lubricants other than recommended may shorten the engine life.
- Viscosity must be appropriate to the ambient temperature to which the engine is to be exposed (Par. 2.4.1).



Danger

- Prolonged skin contact with the exhausted engine oil can cause cancer of the skin.
- If contact with oil cannot be avoided, thoroughly wash your hands with soap and water as soon as possible.
- For the exhausted oil disposal, refer to [Par. 6.5 DISPOSAL and SCRAPPING.](#)

2.4.1 SAE oil classification

- In the SAE classification, oils are identified according to viscosity without considering any other qualitative characteristic.
- The code is made up of two numbers. The first number refers to the viscosity when cold, for use during winter ("W"= winter), while the second number is for viscosity at high temperatures.

2.2

RECOMMENDED OIL

VISCOSITY	SAE	15W-40 (-15°C ÷ +50°C) 10W-30 (-25°C ÷ +40°C) 10W-40 (-25°C ÷ +50°C) 5W-30 (-30°C ÷ +40°C) 0W-40 (-40°C ÷ +50°C)
	API	CJ-4 Low S.A.P.S
WITH SPECIFICATIONS	ACEA	E9 Mid S.A.P.S. E6 Low S.A.P.S.

- Low S.A.P.S. technology (fuel with low Sulfated Ash, Phosphorus, Sulfur content) keeps catalyst in good working conditions. The presence of sulfated ash, phosphorus and sulfur causes with time the catalyst clogging and its consequent inefficiency.
- For Mid S.A.P.S oil sequence the sulfated ash level is the same as API CJ-4 $\leq 1.0\%$ but as per ACEA standardization those oils are referenced as mid SAPS.
- Filtration of oils is critical to proper operation and lubrication; always change filters regularly as specified in this manual.

2.5 Fuel



Important

- Use of other types of fuel could damage the engine. Do not use dirty diesel fuel or mixtures of diesel fuel and water since this will cause serious engine faults.
- Any failures resulting from the use of fuels other than recommended will not be warranted.



Warning

- Clean fuel prevents the fuel injectors from clogging. Immediately clean up any spillage during refuelling.
- Never store diesel fuel in galvanized containers (i.e. coated with zinc). Diesel fuel and the galvanized coating react chemically to each other, producing flaking that quickly clogs filters or causes fuel pump and/or injector failure.

2.3

FUEL COMPATIBILITY

EN 590 (biodiesel content max. 7% (V/V))
ASTM D 975 Grade 1-D S15
ASTM D 975 Grade 2-D S15
NATO F-54, equivalent to diesel fuel in accordance with EN 590
EN 590 or ASTM D 975 Grade 1, 2 -D S15 Arctic Diesel
JIS K 2204 No. 1, No. 2

NOTE: *In a warranty case the customer must prove by a certificate from the fuel supplier that an allowed fuel was used.*

KDI Electronic Injection Tier 4 final – Stage IIIB – Stage IV- Stage V certified Engines

Those engines are designed for fuels in accordance with EN 590 and ASTM D975 for a cetane number of at least 45. Since those engines are equipped with exhaust gas after-treatment such as Diesel Oxidation Catalyst (DOC), Diesel Particulate Filter (DPF), Selective Catalytic Reduction (SCR), they may only be operated with sulfur-free diesel fuels (EN 590, DIN 5168, ASTM D975 Grade 2-D S15, ASTM D975 Grade 1-D S15). Otherwise, compliance with the emission requirements and durability are not guaranteed.

Insufficient lubricating capacity can lead to serious wear problems above all in common rail injection systems. Too low a lubricating capacity is particularly a problem in fuels with a low sulfur content (and in this respect sulfur contents <500 mg/kg can already be considered low). An adequate lubricating capacity is guaranteed by the appropriate additives in low-sulfur (<50 mg/kg) or sulfur-free (<10 mg/kg or <15 mg/kg) diesel fuels according to EN 590 and ASTM D 975. In low-sulfur and sulfur-free diesel fuels which do not comply with this standard, the lubricating capacity may have to be guaranteed by additives. The parameter for sufficient lubricating capacity is a maximum wear spot of 460 micrometers in the HFRR test (EN ISO 12156-1).

2.5.1 Fuel for low temperatures

- When operating the engine in ambient temperatures lower than 0 degrees C, use suitable low temperature fuel normally available from fuel distributors and corresponding to the specifications of [Tab. 2.3](#).
- These fuels reduce the formation of paraffin in diesel at low temperatures.
- When paraffin forms in the diesel, the fuel filter becomes blocked interrupting the flow of fuel.

2.5.2 Biodiesel fuel

- Fuels containing 10% methyl ester or B10, are suitable for use in this engine provided that they meet the specifications listed in the [Tab. 2.3](#).
- DO NOT USE vegetable oil as a biofuel for this engine.

2.4

BIODIESEL COMPATIBILITY

Biodiesel according to EN 14214 (only permissible for mixture with diesel fuel at max. 10% (V/V))

US biodiesel according to ASTM D6751 – 09a (B100) (only permissible for mixtures with diesel fuel at 10% (V/V))

2.5.3 Synthetic fuels: GTL, CTL, BTL, HV

It is a well-known fact that engines which are operated for longer periods with conventional diesel fuel and then converted to synthetic fuels suffer shrinkage of polymer seals in the injection system and thus fuel leaks. The reason for this behavior is that the aromatic-free synthetic fuels can lead to a change in the swelling behavior of polymer seals.

Therefore, conversion from diesel fuel to synthetic fuel may only be done after changing the critical seals. The problem of shrinkage does not occur when an engine was operated with synthetic fuel from the start.

2.5.4 Emission-Related Installation Instructions

Failing to follow the instructions in the applications guidebook when installing a certified engine in a piece of nonroad equipment violates federal law (40 CFR 1068.105(b)), subject to fines or other penalties as described in the Clean Air Act.

OEM must apply a separate label with the following statement: "ULTRA LOW SULFUR FUEL ONLY" near the fuel inlet.

Ensure you are installing an engine appropriately certified for your application. Constant speed engines may only be installed on constant speed equipment for constant speed operation.

If you install the engine in a way that makes the engine's emission control information label hard to read during normal engine maintenance, you must place a duplicate label on the equipment, as described in 40 CFR 1068.105.

2.6 AdBlue

- Also known as "AUS 32" in Europe, "DEF" or "Urea Solution" in the USA, it is registered with the "AdBlue®" brand at the Verband der Automobilindustrie (VDA), and must comply with the following ISO standards:
 - ISO 22241-1 Quality requirements
 - ISO 22241-2 Test Methods
 - ISO 22241-3 Handling, transportation and Storing
 - ISO 22241-4 Refilling Interface
- The AdBlue® tank must be filled by means of the specific automatic filling nozzle at the authorised distributors, refer to the car manual for refilling operations.
- Upon refilling, comply with the MAX level indicated on the tank.
- During the refilling operations prevent any impurity from entering the tank.
- At tank inlet there is a filter that must be periodically cleaned or replaced (see maintenance and replacement table - for tank supplied by Kohler only).
- AdBlue® quality must comply with the specifications described in Table 2.5.



Warning

- Do not mix AdBlue® with fuel or other liquids (including water) and do not fill the fuel tank with AdBlue®.
- The presence of AdBlue® inside the specific tank is required to start the engine.
- Purchase in containers: the container, even if opened, can be stocked with the same conditions of a sealed container.
- Do not stock the container with a temperature higher than 35°C as this could alter the AdBlue®.
- In case of AdBlue® freezing inside the container (< 11°C | 51.8°F), AdBlue® can be used when it returns to its liquid state.
- Do not expose AdBlue® to direct sunlight.
- In case of opening and closing of the original purchase container, AdBlue® must be checked through a spectrometer to check its quality before use.
- Do not insert altered AdBlue® in the tank as the engine could not respect the emission parameters, generate DCU errors and as a consequence turn off or fail to start the engine.

2.5

PARAMETERS	UNIT OF MEASUREMENT	VALUE
Title	Weight %	31,8 ÷ 33,2
Density at 20°C	kg/m ³	1.087 ÷ 1.093
Refraction index at 20°C	°C	1,3814 ÷ 1,3843
Alkalinity like NH ₃	Weight %	< 0,2
Biuret	Weight %	< 0,3
Aldehyde	mg/kg	< 5
Insoluble	mg/kg	< 20
Phosphates like PO ₄	mg/kg	< 0,5
Calcium	mg/kg	< 0,5
Iron	mg/kg	< 0,5
Copper	mg/kg	< 0,2
Zinc	mg/kg	< 0,2
Chrome	mg/kg	< 0,2
Nickel	mg/kg	< 0,2
Aluminium	mg/kg	< 0,5
Magnesium	mg/kg	< 0,5
Sodium	mg/kg	< 0,5
Potassium	mg/kg	< 0,5
Freezing point	°C	11

2.6 Coolant recommendation

A mixture of 50% demineralized water and 50% low silicate ethylene glycol based coolant liquid must be used. Use a Long Life or Extended Life Heavy Duty OAT coolant free of: silicates, phosphates, borates, nitrites and amines. The following ethylene-glycol based engine coolant for all models within KDI engine family may be used:

- OAT (Organic Acid Technology) Low Silicate: **ASTM D-3306 D-6210**
- HOAT (Hybrid Organic Acid Technology) Low Silicate: **ASTM D-3306 D-6210**

The above coolants in concentrated formulation must be mixed with distilled, deionized, or demineralized water. A pre-mixed formulation (40-60% or 50-50%) can be used directly when available.



Important

- Do not mix ethylene glycol and propylene glycol based coolants. Do not mix OAT and HOAT based coolant. OAT performance life can be drastically reduced if contaminated with nitrite-containing coolants.
- Never use automotive-type coolants. These coolants do not contain the correct additives to protect heavy – duty diesel engines.

OAT coolants are maintenance free up to 6 years or 6000hrs of operation , provided that the cooling system is topped up using the same type of coolant. Do not mix different coolant types. Test the coolant condition annually with coolant test strips. HOAT are not all maintenance free and it is recommended to have SCA (Supplemental Coolant Additives) added at the first maintenance interval

2.8 Battery recommendation

Battery not supplied by Kohler

2.6

RECOMMENDED BATTERIES	
AMBIENT TEMPERATURE	BATTERY TYPE
≥ - 15°C	120 Ah/20 h - 1000 CCA/SAE
< -15°C	130 Ah/20 h - 1100 CCA/SAE

2.9 Inducement strategy of SCR system

The inducement is the operation aimed at reducing the engine performance due to a malfunction or tampering with the SCR system detected by the DCU.

The inducement degree is decided by the ECU according to the error detected by the DCU.

The inducement can have the following 2 levels:

- Level 1: 25% reduction of the MAX available torque.
- Level 2: 50% reduction of the MAX available torque and 40% reduction of MAX rpm available.

Before activating the inducement (level 1 or level 2) the ECU activates a warning or a warning light on the car panel (refer to the car documentation for the warning type).

The information on the car panel or the activation of the inducement can occur for the following reasons:

- Low AdBlue® level
- Poor AdBlue® quality
- Interruption of AdBlue® supply
- EGR valve malfunctioning
- Tampering with the monitoring systems of the SCR system.

The inducement strategy is applied according to:

- detected problem
- hours passed.

NOTE: *Hours are reset after 40h if the DCU does not detect any fault, otherwise the hours are added to those already counted. For low AdBlue® level, activation depends on the percentage of liquid inside the AdBlue® tank, and the fault hours are not counted.*

The strategy for the different faults is listed below:

Low AdBlue® level

- information activation on car panel: <10% of MAX level
- Level 1 inducement: <2.5% of MAX level
- Level 2 inducement: 0% of MAX level

Poor AdBlue® quality

- information activation on car panel: upon fault detection
- Level 1 inducement: after 10h from fault detection
- Level 2 inducement: after 20h from fault detection

Interruption of AdBlue® supply

- information activation on car panel: upon fault detection
- Level 1 inducement: after 10h from fault detection
- Level 2 inducement: after 20h from fault detection

EGR valve malfunctioning

- information activation on car panel: upon fault detection
- Level 1 inducement: after 36h from fault detection
- Level 2 inducement: after 100h from fault detection

Tampering with the monitoring systems of the SCR system

- information activation on car panel: upon fault detection
- Level 1 inducement: after 36h from fault detection
- Level 2 inducement: after 100h from fault detection

3.1 Safety information

- The intended use of the engine is in conformity with the machine on which it is mounted.
- Any use of the machine other than that described cannot be considered as complying with its intended purpose as specified by KOHLER .
- KOHLER declines all responsibility for any change to the engine not described in this manual made by unauthorized KOHLER personnel.
- A proper use of the engine, a strict observance of the rules listed below and the rigorous application of all these precautions will avoid the risk of accidents or injuries.
- Those who carry out the use and maintenance on the engine must wear the safety equipment and the accident-prevention guards.
- KOHLER declines all direct and indirect liability for failure to comply with the standards of conduct contained in this manual.
- KOHLER cannot consider every reasonably unforeseeable misuse that may cause a potential danger.

3.2 General remarks

3.2.1 Note for OEM

- When installing the KDI engines, always bear in mind that any variation to the functional systems may result in serious failures to the engine.
- Any improvement must be verified at KOHLER testing laboratories before application of the engine.
- In case the approval to a modification is not granted, KOHLER shall not be deemed responsible for any consequential failures or damages to the engine.
- The engine may only be assembled on a machine by personnel specifically trained by KOHLER and who work in compliance with the existing documentation.
- The engine has been built to the specifications of a machine manufacturer, and it is his responsibility to ensure that all necessary action is taken to meet the essential and legally prescribed health and safety requirements. Any use of the machine other than that described cannot be considered as complying with its intended purpose as specified by KOHLER, which therefore declines all responsibility for accidents caused by such operations.

3.2.2 Note for end user

- The following indications are dedicated to the user of the machine in order to reduce or eliminate risks concerning engine operation and the relative routine maintenance work.
- The user must read these instructions carefully. Failure to do this could lead to serious danger for his personal safety and health and that of any persons who may be in the vicinity of the machine.
- On starting, make sure that the engine is as horizontal as possible, unless the machine specifications differ.
- Make sure that the machine is stable to prevent the risk of overturning.
- The engine must not operate in places containing inflammable materials, in explosive atmospheres, where there is dust that can easily catch fire unless specific, adequate and clearly indicated precautions have been taken and have been certified for the machine.
- To prevent fire hazards, always keep the machine at least one meter from buildings or from other machinery.
- Children and animals must be kept at a due distance from operating machines in order to prevent hazards deriving from their operation.
- Thoroughly wash and clean all the external parts of the engine before performing any operation, in order to avoid the accidental introduction of impurities/foreign bodies. Use only water and/or appropriate products to clean the engine. If cleaning engine with a pressure washer or steam cleaner, it is important to maintain a minimum distance of at least 200mm between the surface to be washed and the nozzle. Avoid directing the nozzle on electrical components, cable connections and sealed rings (oil seals etc).
- Thoroughly wash and clean the area surrounding the engine following the instructions provided by machine manufacturer.
- Fuel and oil are inflammable. The tank must only be filled when the engine is off. Before starting, dry any spilt fuel.
- Make sure that no soundproofing panels and the ground or floor on which the machine is standing have not soaked up any fuel.
- Fuel vapour is highly toxic. Only refuel outdoors or in a well ventilated place.
- Do not smoke or use open flames when refuelling.
- During operation, the surface of the engine can become dangerously hot. Avoid touching the exhaust system in particular.
- Before proceeding with any operation on the engine, stop it and allow it to cool.
- Always open the radiator plug or expansion chamber with the utmost caution, wearing protective garments and goggles.
- The coolant fluid is under pressure. Never carry out any inspections until the engine has cooled.
- If there is an electric fan, do not approach the engine when it is still hot as the fan could also start operating when the engine is at a standstill.



Important

- The oil must be drained whilst the engine is hot. Particular care is required to prevent burns. Do not allow oil to come into contact with the skin because of the health hazards involved. It is recommended to use an oil intake pump.
- During operations that involve access to moving parts of the engine and/or removal of rotating guards, disconnect and insulate the negative wire (-) of the battery to prevent accidental short-circuits and to stop the starter motor from being energized.
- Check belt tension only when the engine is off.
- Fully tighten the tank cap each time after refuelling. Do not fill the tank right to the top but leave an adequate space for the fuel to expand.
- To start the engine follow the specific instructions provided in the engine and/or machine operating manual. Do not use auxiliary starting devices not originally installed on the machine (e.g. Startpilot).
- Before starting, remove any tools that were used to service the engine and/or machine. Make sure that all guards have been refitted.
- Do not mix fuel with elements such as oil or kerosene. Failure to comply with this prohibition will cause the non-operation of the catalyst and non-observance of the emissions declared by KOHLER.
- Pay attention to the temperature of the oil filter when the filter itself is replaced.

- Only check, top up and change the coolant fluid when the engine is off and reached the ambient temperature. Coolant fluid is polluting, it must therefore be disposed of in the correct way.
- Do not use air and water jets at high pressures on cables, connectors and injectors.



Important

- Only use the eyebolts A installed by KOHLER to move the engine (Fig. 3.1).
- The angle between each lifting chain and the eyebolts shall not exceed 15° inwards.
- The correct tightening of the lifting screws is 25Nm.
- Do not interpose spacers or washers between the eyebolts and engine head.
- Provided that the above requirements are met, if the lifting eyebolts are subject to permanent deformation (inwards), all subsequent lifting operations must be performed in order to prevent them from bending in the opposite direction.

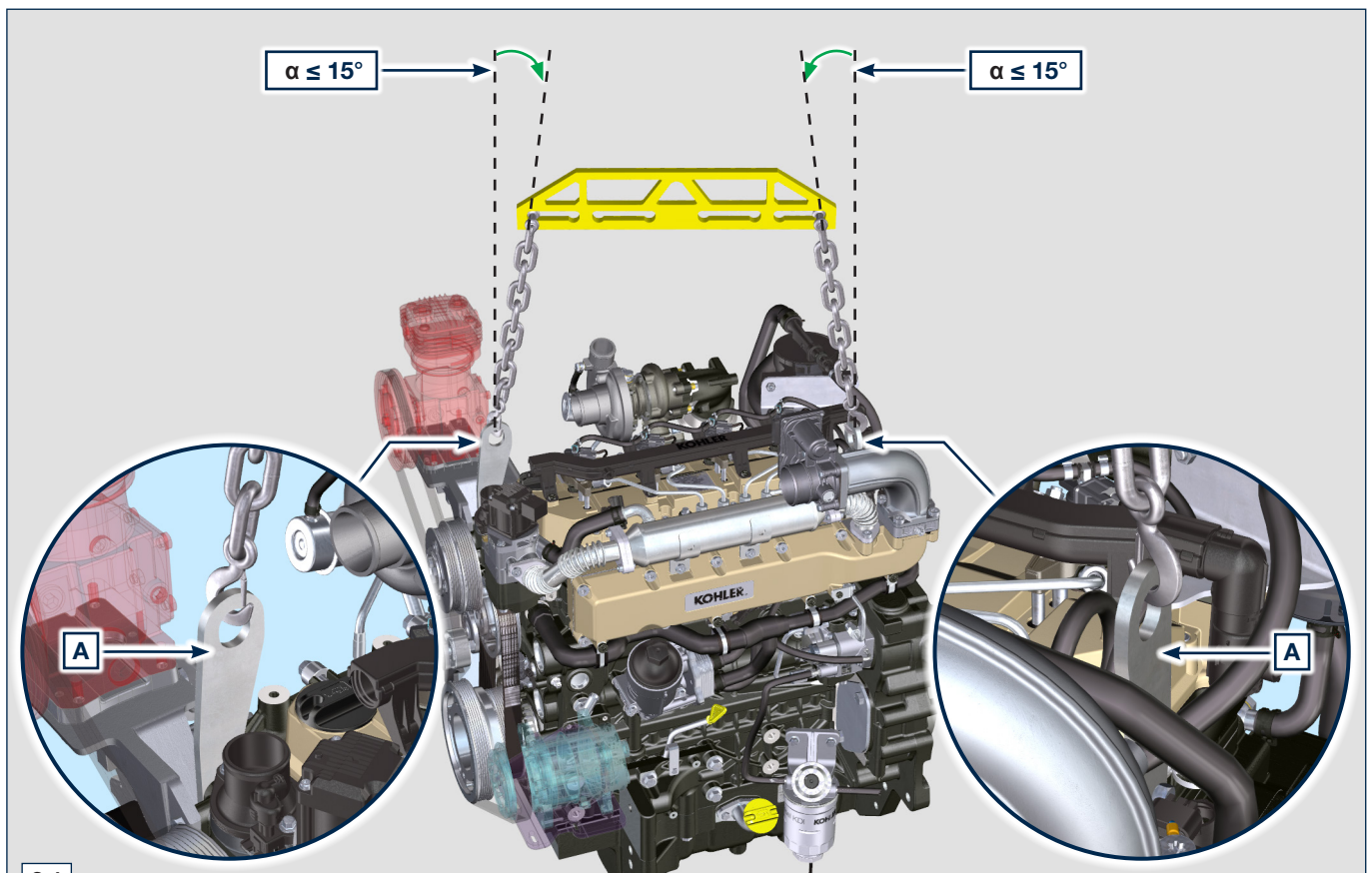

3.1

3.3 Safety signal description

- To ensure safe operation please read the following statements and understand their meaning.
- Also refer to your equipment manufacturer's manual for other important safety information.
- This manual contains safety precautions which are explained below.
- Please read them carefully.

3.3.1 Adhesive safety plates

The following is a list of the adhesive safety plates that may be found on the engine, which indicate potential points of danger to the operator ([Par. 3.6](#)).



Read the Operation and Maintenance handbook before performing any operation on the engine.



Hot Parts.
Danger of burns.



Presence of rotating parts.
Danger of jamming or cutting.



Presence of explosive fuel.
Danger of fire or explosion.



Presence of steam and pressurized coolant.
Danger of burns.



Lifting point.



Electrical shock.
Danger of severe scalding or death.



High pressure fluid.
Danger of fluid penetration.



Lethal Exhaust Gases.
Danger of poisoning or death.

3.3.2 Safety guards

Hereunder is a list of safety guards that must be worn prior to carrying out any type of operation and to avoid potential harm to the operator.



Use protective gloves before carrying out the operation.



Use protective glasses before carrying out the operation.



Use sound absorbing protections before carrying out the operation.

3.3.3 Warnings

Hereunder is a list of safety warnings that may be found in the manual, which advise you to pay attention when carrying out particular procedures that may be potentially dangerous to the operator or things.



Danger

- This indicates situations of grave danger which, if ignored, may seriously threaten the health and safety of individuals.



Important

- This indicates particularly important technical information that should not be ignored.



Warning

- This indicates that failure to comply with it can cause minor damage or injury.

3.4 Information and safety signals

	ACCIDENTAL START
 	Accidental Starts can cause severe injury or death.
<i>Before working on the engine or equipment, disconnect the battery negative (-) wire.</i>	

	HOT PARTS
	Hot Parts can cause severe burns.
<i>Engine components can get extremely hot from operation. Do not touch engine while operating or just after stopping. Never operate the engine with heat shields or guards removed.</i>	

	ROTATING PARTS
	Rotating Parts can cause severe injury.
<i>Stay away while engine is in operation. Keep hands, feet, hair, and clothing away from all moving parts to prevent injury. Never operate the engine with covers, shrouds, or guards removed.</i>	

LETHAL EXHAUST GASES	
 	Carbon Monoxide can cause severe nausea, fainting or death.
<i>Avoid inhaling exhaust fumes and never run the engine in a closed building or confined area. Carbon monoxide is toxic, odorless, colorless, and can cause death if inhaled.</i>	

ELECTRICAL SHOCK	
 	Electrical Shock can cause injury.
<i>Do not touch wires while engine is running.</i>	

	HIGH PRESSURE FLUID RISK OF PUNCTURE
	High Pressure Fluids can puncture skin and cause severe injury or death.
<i>Do not work on fuel system without proper training or safety equipment. Fluid puncture injuries are highly toxic and hazardous. If an injury occurs, seek immediate medical attention.</i>	

	EXPLOSIVE FUEL
	Explosive fuel can cause fires and severe burns.
<i>Fuel is flammable and its vapours can ignite. Store fuel only in approved containers, in well ventilated, unoccupied buildings. Do not fill the fuel tank while the engine is hot or running, since spilled fuel could ignite if it comes in contact with hot parts or sparks from ignition. Do not start the engine near spilled fuel. Never use fuel as a cleaning agent.</i>	

	EXPLOSIVE GAS
	Explosive Gas can cause fires and severe acid burns.
<i>Charge battery only in a well ventilated area. Keep sparks, open flames, and other sources of ignition away from the battery at all times. Batteries produce explosive hydrogen gas while being charged. Keep batteries out of the reach of children. Remove all jewelry when servicing batteries. Before disconnecting the negative (-) ground cable, make sure all switches are OFF. If ON, a spark will occur at the ground cable terminal which could cause an explosion.</i>	

CALIFORNIA WARNING - DECLARATION 65	
<i>Engine exhaust from this product contains chemicals known to the State of California to cause cancer, birth defects, or other reproductive harm.</i>	

3.5 Safety and environmental impact

Every organisation has a duty to implement procedures to identify, assess and monitor the influence of its own activities (products, services, etc.) on the environment. Procedures for identifying the extent of the impact on the environment must consider the following factors:

- Liquid waste.
- Waste management.
- Soil contamination.
- Atmospheric emission.
- Use of raw materials and natural resources.
- Regulations and directives regarding environmental impact.

In order to minimise the impact on the environment, KOHLER now provides a number of indications to be followed by all persons handling the engine, for any reason, during its expected lifetime.

- All components and fluids must be disposed of in accordance with the laws of the country in which disposal is taking place.
- Keep the fuel and engine control systems and the exhaust pipes in efficient working order to limit environmental and noise pollution.
- When discontinuing use of the engine, select all components according to their chemical characteristics and dispose of them separately.

3.6 Location of safety labels on engine

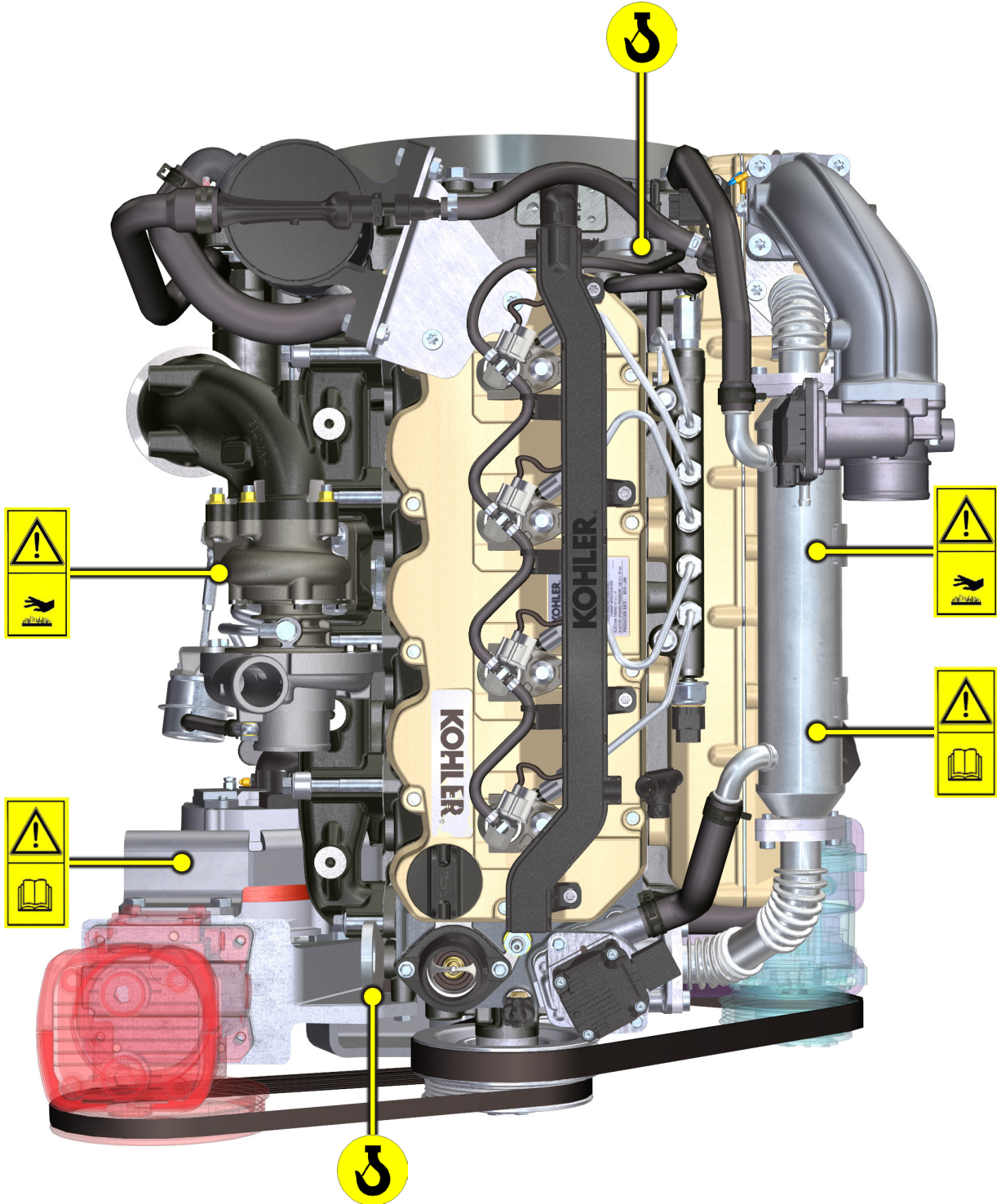

4.1 Pre-start check



Important

- Read carefully the following pages and carry out the operations described below in accordance with the instructions specified.
- Non compliance with the operations described in the following pages involves the risk of damages to the engine and vehicle on which it is installed as well as personal and/or property damage.
- Increase the frequency of maintenance operations in heavy working conditions (engine starts but stops, very dusty and hot environments, etc...).
- Check that the minimum required AdBlue® quantity is present inside the AdBlue® tank. Refer also to the car documentation to check the AdBlue® level required for engine correct operation.

4.2 Running-in period

NOTE: For the first 50 hours of engine operation, it is advisable not to exceed 75% of the maximum power supplied.

4.3 Starting and turning off

4.3.1 Starting

1. Check the level of the engine oil, fuel, coolant and AdBlue®, fill if necessary ([Par. 4.5](#) and [Par. 4.6](#)).
2. Put the ignition key in the ignition switch (if supplied).
3. Turn the key to ON position.
4. Turn the key beyond the ON position and release it when the engine starts (the key will return into ON position automatically).



Important

- Do not actuate the starter for more than 15 seconds at a time. If the engine does not start, wait for one minute before repeating attempt.
 - If engine does not start after two attempts see [Tab. 7.1](#) and [Tab. 7.2](#), to locate the cause.

4.3.2 After starting



Warning

- Make sure that all the warning lights on the control panel are off when the engine is running.
- Run at minimum speed for a few minutes according to table (except constant speed engine).

AMBIENT TEMPERATURE	TIME
≤ -20°C	2 minutes
from -20° C to -10°C	1 minutes
from -10° C to -5° C	30 seconds
from -5° C to 5° C	20 seconds
≥ 5° C	15 seconds

4.3.3 Turning off

1. Do not turn off the engine when it is running at the maximum rotation speed (except constant speed engine).
2. Before turning it off, keep it idle at minimum speed for about 1 minute.
3. Turn the key to OFF position.

4.4 Refuelling



Important

- Before proceeding with operation, read [Par. 3.2.2](#).



Danger

- Fill the engine off.
- The only approved fuels are those listed in [Tab. 2.3](#).
- In those countries where diesel has a high sulphur content, it is advisable to lubricate the engine with a high alkaline oil or alternatively to replace the lubricating oil recommended by KOHLER more frequently.
- To avoid explosions or fire outbreaks, do not smoke or use open flames during the operations.
- Fuel vapours are highly toxic. Only carry out the operations outdoors or in a well ventilated place.
- Keep your face well away from the fuel fill to prevent harmful vapours from being inhaled.
- Dispose of fuel in the correct way and do not litter as it is highly polluting.
- When refuelling, it is advisable to use a funnel to prevent fuel from spilling out. The fuel should also be filtered to prevent dust or dirt from entering the tank.
- Do not overfill the fuel tank. Leave room for the fuel to expand.

NOTE: *At the first fuelling or if the tank was empty filling the fuel system ([Par. 6.3 point 8](#)).*

4.5 Oil filling



Important

- For safety precautions see [Par. 2.4](#).
- Before proceeding with operation, read [Par. 3.2.2](#).

1. Loosen the oil filler cap A.
2. Add the type oil recommended ([Tab. 2.1](#) and [Tab. 2.2](#)).

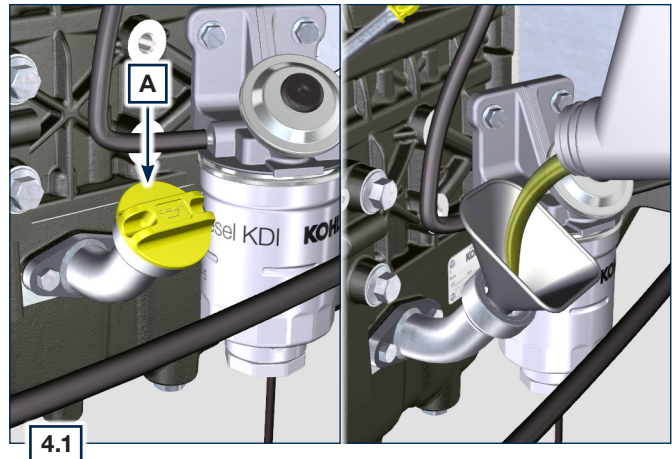

3. Before checking oil engine needs to be level.
4. Remove the oil dipstick B and check that the level is up to but does not exceed the MAX.
5. If level is not at the MAX. level, add additional oil.
6. Re-tighten the cap A.



Important

- Do not use the engine with the oil level below the minimum.

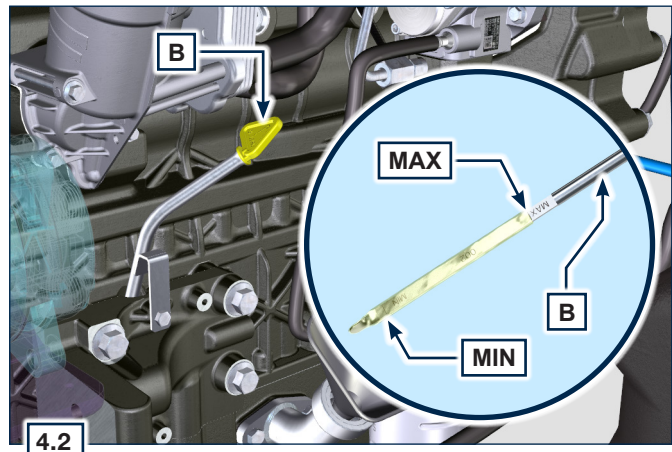

4.6 Coolant filling



Important

- Before proceeding with operation, read [Par. 3.2.2](#).

NOTE: *Refer to the technical documentation of the vehicle.*



Warning

- An anti-freeze protection liquid (ANTIFREEZE) - mixed with decalcified water - must be used.
- The freezing point of the refrigerant mixture depends on the amount concentration in water.
- As well as lowering the freezing point, the antifreeze also raises the boiling point.
- A 50% mixture is recommended to ensure a general level at protection prevents the formation of rust, galvanic currents and calcium deposits ([Par. 2.7](#)).

4.7 AdBlue® filling

NOTE: *Refer to the technical documentation of the vehicle.*

5.1 Useful information about maintenance

- This chapter shows all operations described in the Tab. 5.1 and Tab. 5.2 if you have the skills appropriate may be directly carried out by the user.
- Periodic inspection and maintenance operations must be carried out as indicated in this manual and are the responsibility of the user.
- Failure to comply with these service and maintenance intervals increases the risk of technical damage to the engine. Any non compliance makes the warranty become null and void.
- In order to prevent personal and property damage read carefully the instructions listed below before proceeding with any operation of the engine.



Important

- Before proceeding with operation, read [Par. 3.2.2](#).



Warning

- Inspections must be made when the engine is off and cold.
- Place engine on level surface to ensure accurate measurement of oil level.
- Before starting, to avoid spillages of oil make sure that:
 - the oil dipstick is inserted correctly;
 - also check that: oil drain plug and; oil filler cap are tightened firmly.

5.2 Periodic maintenance

The intervals of preventive maintenance in Tab. 5.1 and Tab. 5.2 refer to the engine operating under normal operating conditions with fuel and oil meeting the recommended specifications.

5.7

CLEANING AND CHECKING

OPERATION DESCRIPTION	PERIOD (HOURS)				PAR.
	100	250	500	5000	
Engine oil level ⁽⁸⁾					5.3
Coolant level ⁽⁹⁾	Components not supplied by KOHLER. Refer to the technical documentation of the vehicle				5.7
Cartridge dry-type air filter ⁽²⁾					5.4
Radiator heat-exchange surface and Intercooler ⁽²⁾					5.5
Alternator belt ⁽⁸⁾					5.8
Rubber hose (intake air / coolant)					5.6
Fuel hose					--
Starter Motor ⁽⁶⁾					--
Alternator ⁽⁶⁾					--

5.8

REPLACEMENT

OPERATION DESCRIPTION	PERIOD (HOURS)				PAR.
	500	1500	5000	6000	
Engine oil ⁽¹⁾					6.1
Oil filter cartridge ⁽¹⁾					6.2
Fuel filter and pre-filter cartridge ⁽¹⁾					6.3
AdBlue [®] filter cartridge ⁽⁶⁾					--
Coolant hoses ^{(6) (7)}					--
Fuel line hose ^{(6) (7)}					--
Intake manifold hose (air filter - intake manifold) ^{(6) (7)}					
Alternator belt	Poly-V belt heavy environmental condition ⁽⁶⁾				--
	Poly-V belt standard condition ⁽⁶⁾				
Coolant	OAT ⁽⁶⁾				--
	HOAT ^{(6) (10)}				
Cartridge dry-type air filter ⁽²⁾	Components not supplied by KOHLER. Refer to the technical documentation of the vehicle				6.4

1. In case of low use: 12 months.
2. The period of time that must elapse before checking the filter element depends on the environment in which the engine operates. The air filter must be cleaned and replaced more frequently under very dusty conditions.
6. Contact authorized KOHLER workshops.
7. The replacement interval is only an indication, it strongly depends from environmental condition and hose status detected during regular visual inspection.
8. The first check must be done after 10 hours.
9. Test the coolant condition annually with coolant test strips.
10. It is recommended to have SCA (Supplemental Coolant Additives) added at the first maintenance interval.

5.3 Oil level check

1. Loosen the oil filler cap A.
Remove the oil dipstick B and check that the level is up to MAX.
2. Pour in recommended oil until reaching the MAX level mark.
3. Reinstall the oil dipstick B completely.
4. Re-tighten the cap A (Fig. 5.2).



Important

- Do not use the engine with the oil level below the minimum.

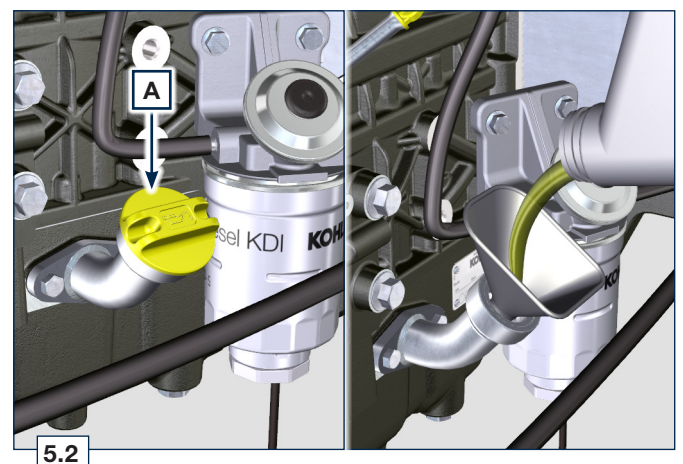
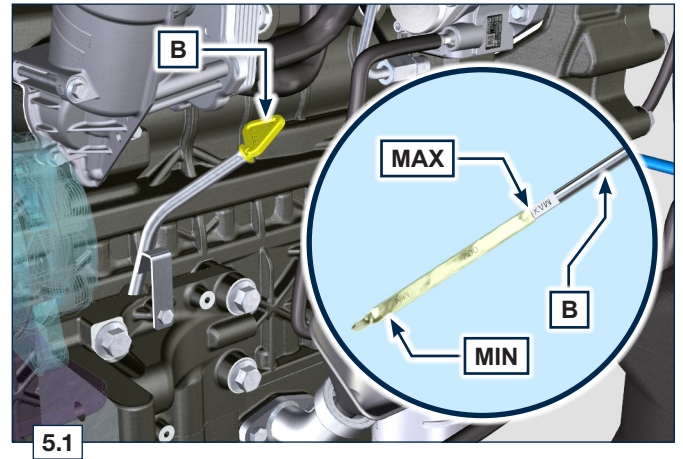

5.4 Air filter check

NOTE: *Component not supplied by KOHLER.
Refer to the technical documentation of the vehicle.*



Danger

- For safety precautions see [Cap. 3](#).

5.5 Check of the radiator heat-exchanger surface

NOTE: *Component not supplied by KOHLER.
Refer to the technical documentation of the vehicle*

5.6 Rubber hoses check

The check is carried out by exerting a slight deflection or bending along the pipe and near the hose clamps.

Components must be replaced if they have clear signs of cracks, tears, cuts, leaks and do not retain a certain degree of elasticity.



Important

- Before proceeding with operation, read [Par. 3.2.2](#).
- If hoses are damaged contact an authorized KOHLER workshop.
- For other pipes not illustrated refer to the technical documentation of the vehicle.

1. Check that the:

- Fuel system hoses A are intact.
-
- Cooling circuit hoses B.
-
- Vent system pipes C.

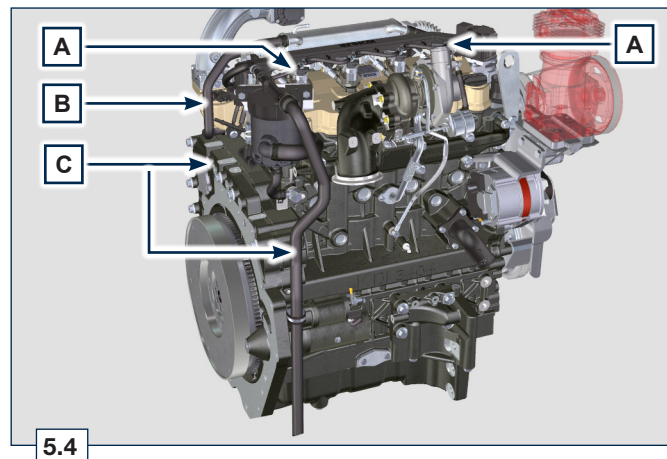
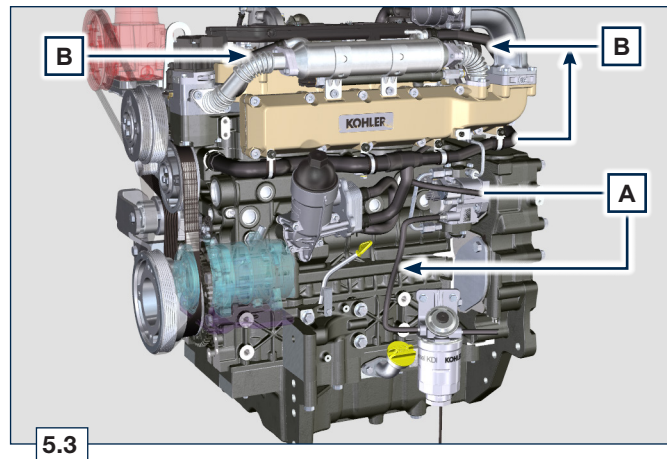

5.7 Check coolant level

NOTE: *Component not supplied by KOHLER.
Refer to the technical documentation of the vehicle.*

5.8 Check Poly-V alternator belt

NOTE: The poly-v belt is not adjustable.

1. Check the belt A condition, if worn out or deteriorated, replace it.

NOTE: Make sure that the ribs of the belt A are inserted correctly into the grooves of the pulleys B (as shown in D1 and D2).

2. Start the engine and run it for some minutes, then turn off it, and let it cool down at ambient temperature. Check by the appropriate tool that at point p the tension value is between 135 and 178 Hz.

NOTE: If the poly-v belt tension results out of the above mentioned values contact KOHLER authorised workshops for replacement.

NOTE: Belts A2, A3 are not supplied by KOHLER. Refer to the technical documentation of the vehicle.

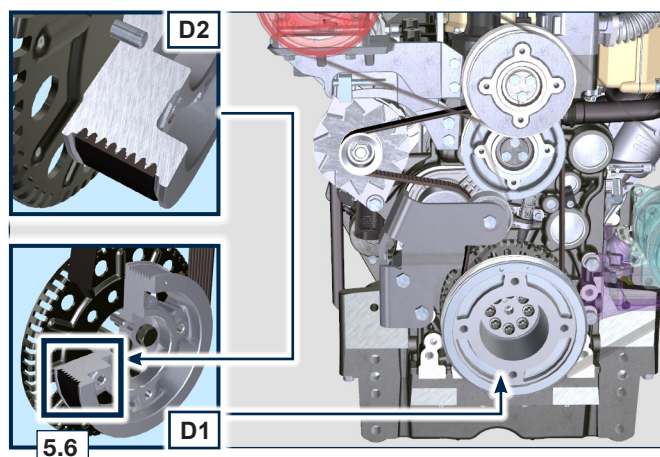
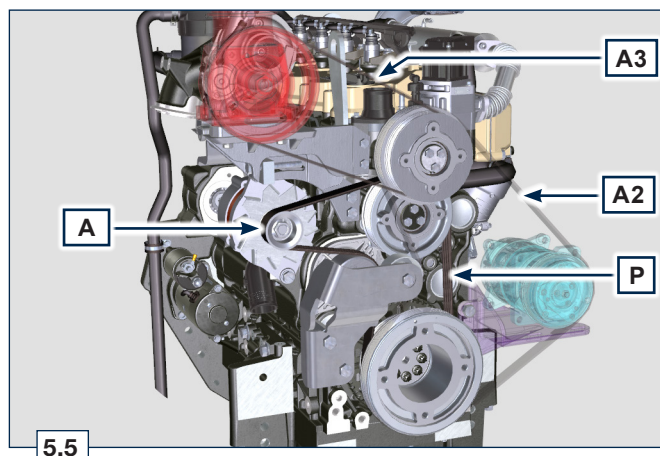

5.9 Check fuel filter cartridge

When turn on lights on control water filter cartridge fuel:

1. Gently loosen the wing screw A without removing it.
2. Drain the water if present.
3. Re-tighten the wing screw A as soon as the fuel begins to flow.

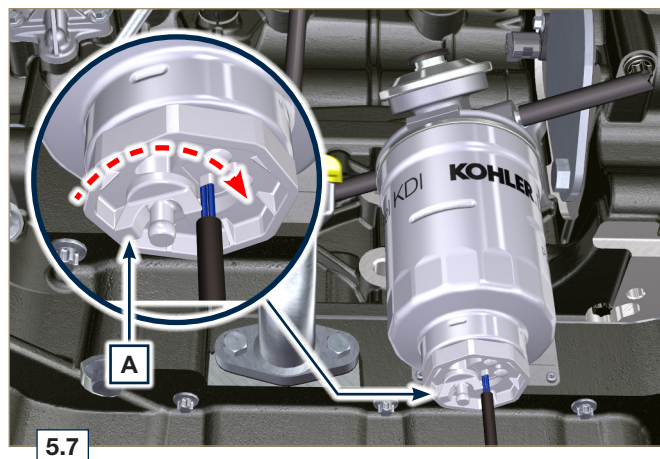

5.10 Product preservation



Important

- If the engines are not to be used for 6 months, they must be protected by carrying out the operations described in Engine storage (up to 6 months) (Par. 5.11).
- If the engine is still not in use after the first 6 months, it is necessary to carry out a further operation to extend the protection period (more than 6 months) (Par. 5.12).
- If the engine is not to be used for an extended period, the protective treatment procedure must be repeated within 24 months of the previous one.

5.11 Engine storage up to 6 months

Before storing the engine check that:

- The environments are not humid or exposed to bad weather. Cover the engine with a proper protective sheet against dampness and atmospheric contaminants.
- The place is not near electric panel.
- Avoid storing the engine in direct contact with the ground.

5.12 Engine storage over 6 months

Follow the steps described in Par. 5.11.

1. Engine oil replacement ([Par. 6.1](#)).
2. Refuel with fuel additives for long storage. The following additives are recommended: DEFA Fluid Plus (Pakelo Lubricants), Diesel Treatment (Green Star), Top Diesel (Bardhal), STP® Diesel Fuel Injector Treatment.
3. With expansion tank: make sure that the coolant is up to the MAX level.
4. Without expansion tank: Top liquid up until the pipes inside the radiator are covered by about 5 mm. Do not overfill the radiator, but leave room for the fuel to expand.
5. Start the engine and keep it idle at minimum speed for 2 minutes.
6. Bring the engine to 3/4 of the MAX speed for 5÷10 minutes.
7. Turn off the engine.
8. Completely empty the fuel tank.
9. Spray SAE 10W-40 on the exhaust and intake manifolds.
10. Seal the exhaust and intake ducts to prevent foreign bodies from entering.

11. When cleaning the engine, if using a pressure washer or steam cleaning device, avoid directing the nozzle on electrical components, cable connections and sealed rings (oil seals etc). If cleaning engine with a pressure washer or steam cleaner, it is important to maintain a minimum distance of at least 200mm between the surface to be washed and the nozzle - avoiding absolutely electrical components such as alternators, starter motors and engine control units (ECU).

12. Treat non-painted parts with protective products.

13. Fill the AdBlue tank to the MAX level allowed.

If the engine protection is performed according to the suggestions indicated no corrosion damage should occur.

5.13 Engine starting after storage

1. Remove the protective sheet.
2. Use a cloth soaked in degreasing product to remove the protective treatment from the external parts.
3. Inject lubricating oil (no more than 2 cm³) into the intake ducts.
4. Refill the tank with fresh fuel.
5. Make sure that the oil and the coolant are up to the MAX level.
6. Proceed with the disposal of the AdBlue contained in the tank; replace the AdBlue pump filter and wash the AdBlue tank/circuit with hot distilled water.
7. Check the AdBlue injector at an authorized **KOHLER** workshop.
8. Start the engine and keep it idle at minimum speed for a two about minutes.
9. Bring the engine to 75% of MAX rated speed for 5 to 10 minute.
10. Stop the engine while the oil is still hot ([Par. 6.1](#)), discharge the protective oil in a suitable container.



Warning

- Over time, lubricants and filters lose their properties, so it is important consider whether they need replacing, also based on the criteria described in [Tab. 5.2](#).
11. Replace the filters (air, oil, fuel) with original spare parts.
 12. Pour new oil ([Par. 4.5](#)) up to the MAX level.
 13. Empty the cooling circuit completely and pour in the new coolant up to the MAX level ([Par. 4.6](#)).



Danger

- Disconnect the negative wire (-) from the battery to avoid accidental engine starting.



Important

- Before proceeding with operation, read [Par. 3.3.2.](#)

6.1 Engine oil replacement



Important

- Place engine on level surface to ensure accurate measurement of oil level.
- Before proceeding, perform the operation described in [Par. 6.2](#) - Point 1.

NOTE: *Perform this operation with warm engine, to get a better fluidity of the oil and get a full discharge of oil and impurities contained in it.*

1. Loosen the oil filler cap A (Fig. 6.1).
2. Remove the oil dipstick B.
3. Remove the oil drain plug D and the gasket E (the oil drain plug is on both sides of the oil sump).
4. Drain oil in an appropriate container (For the exhausted oil disposal, refer to [\(Par. 6.5 DISPOSAL and SCRAPPING\)](#)).
5. Replace gasket E.
6. Tighten the drain oil plug D (tightening torque at 50 Nm).
7. Perform the operation described in [Par. 6.2](#) - point 2 to 5.
8. Add the type oil recommended ([Tab. 2.1 and Tab. 2.2](#)).

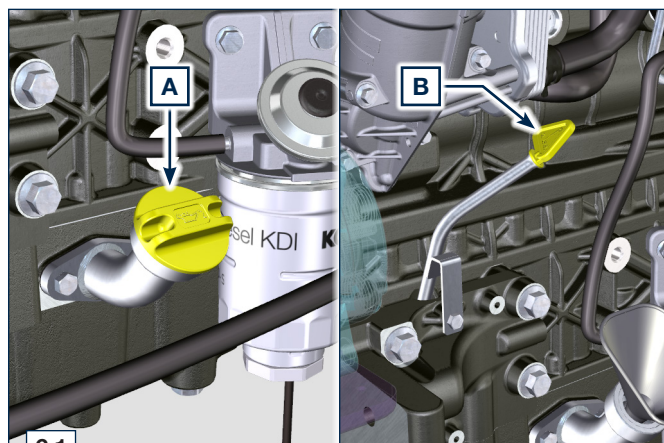

6.1

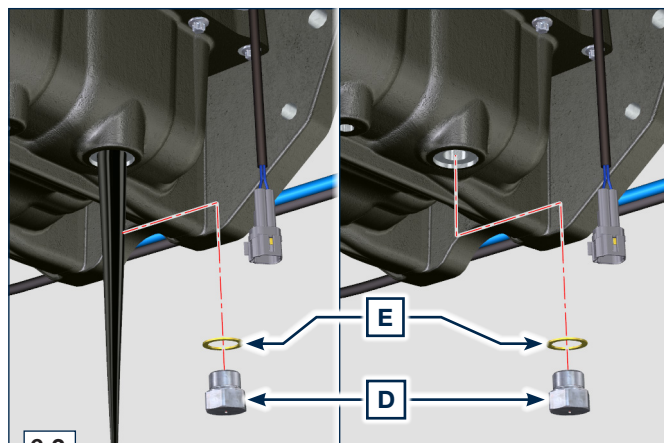

6.2



Important

- Do not exceed the MAX level on the dipstick.
 - Do not use the engine with the oil level below the MIN.
9. Fit and remove the oil dipstick B to check the level. Pour in fluid until reaching the MAX level mark.
 10. Upon completion, reinstall the oil dipstick B completely.
 11. Tighten the cap A.

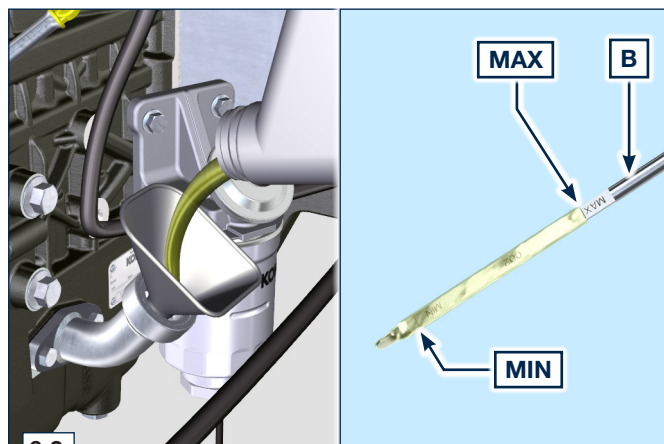

6.3



Warning

- Oil filter cartridge replacement ([Par. 6.2](#)) and fuel filter replacement ([Par. 6.3](#))
 - In case of low use replace it 12 months.
- For disposal of oil filter cartridge and fuel filter refer to [Par. 6.5 DISPOSAL and SCRAPPING.](#)

6.2 Oil filter cartridge replacement



Important

- Electric/pneumatic screwdrivers are forbidden.

1. Unscrew cartridge holder cover A by performing three complete turns and wait 1 minute.

NOTE: *This operation allows to oil contained in the support F to flow into the oil sump in the correct way.*

2. Unscrew cartridge holder cover A and check that the oil in the lub. oil filter support F has flowed towards the oil sump.
3. Remove the cap A as well as the oil cartridge B from the oil filter support.
4. Remove and replace the oil cartridge B with a new one. Remove and replace the gaskets C, D and E with new ones.
5. Fit and tighten the cover A on the oil filter support F, tightening it with a torque wrench G (tightening torque of 25 Nm).

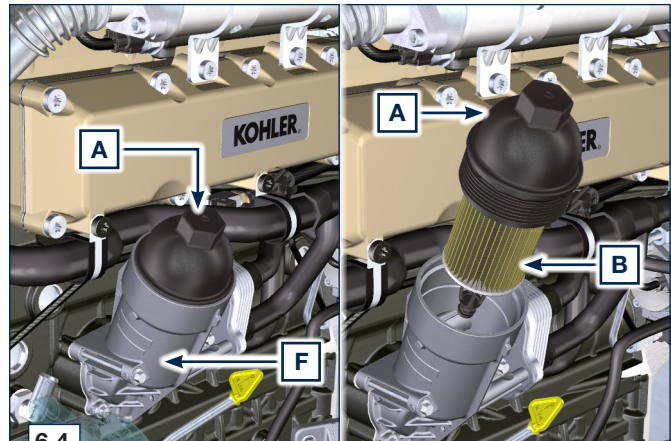

6.4

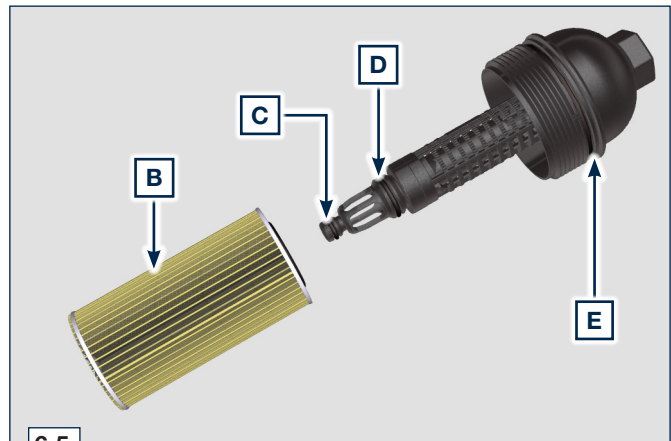

6.5

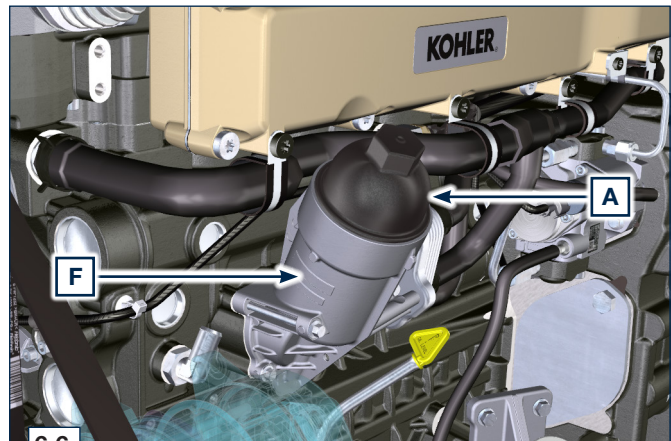

6.6

6.3 Fuel filter cartridge replacement

NOTE: *The fuel filter is situated on the crankcase of the engine or it may be assembled on the frame of the vehicle.*

1. Disconnect the cable A of the water presence sensor C.
2. Remove the water presence sensor C from its cartridge B.
3. Loosen the cartridge B using the appropriate wrench (Fig. 6.9).
4. Lubricate the gasket D of the new cartridge B.



Important

- Do not fill the new cartridge B with fuel.

5. Tighten the new empty cartridge B (Fig. 6.9) on the diesel fuel filter support E using the special wrench (tightening torque of 17 Nm).
6. Tighten the water presence sensor C on the new cartridge B (tightening torque of 5 Nm).
7. Reconnect the cable A of the water presence sensor C.

NOTE: *Bleeding.*

8. Push repeatedly the button G in order to fill the circuit.

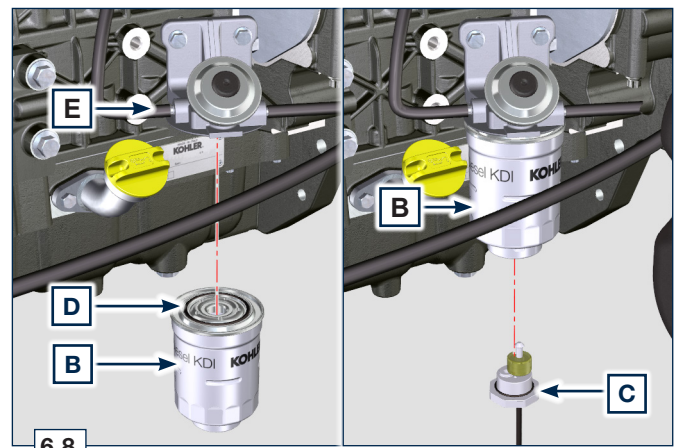
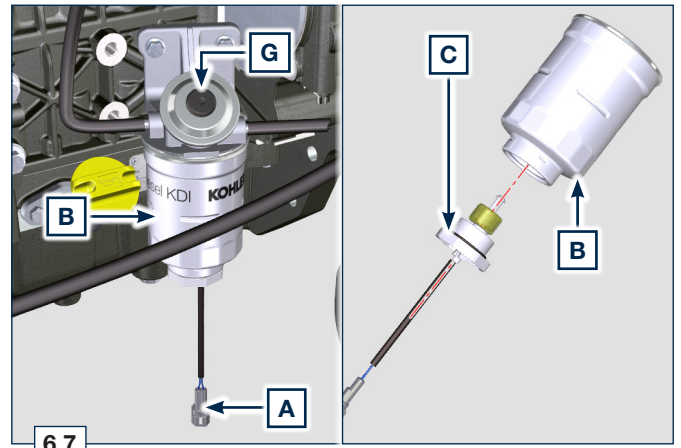

6.4 Air filter cartridge replacement

NOTE: *Component not supplied by KOHLER. Refer to the technical documentation of the vehicle.*

6.5 Disposal and scrapping

- In case of scrapping, the engine shall be disposed of in appropriate locations, in conformity with the law in force.
- Before scrapping, it is necessary to separate the rubber or plastic parts from the rest of the components.
- The parts only composed of plastic material, aluminium and steel can be recycled if collected by the appropriate centers.
- Waste oil must properly be recycled and disposed of in the correct way to safeguard the environment. According to the laws in force, it is classified as hazardous waste, therefore it must be collected by the appropriate centers.

7.1 Useful information about failures

- This chapter contains information about the problems that may appear during engine operation with its causes and trouble shooting Tab. 7.2.
- In some cases, you shall turn off the engine immediately to avoid further damage Tab. 7.1.

7.1	THE ENGINE MUST BE IMMEDIATELY TURNED OFF WHEN
1	Warning RED light turn on
2	The oil pressure indicator light turns on while running
3	The engine rpms suddenly increase and decrease
4	A sudden and/or unusual noise is heard
5	Colour the exhaust fumes suddenly darkens

7.2	TROUBLES	POSSIBLE CAUSE	SOLUTION	PAR.
	Warning YELLOW light turn on	Engine ECU has detect a malfunctions	Contact KOHLER authorised workshops	--
	The engine does not start	Sulphated battery terminals corroded	Clean the battery terminals	--
		Battery voltage too low	Recharge the battery or replace it	--
		Low fuel level	Refuel	4.4
		Frozen fuel	Contact KOHLER authorised workshops	--
		Clogged fuel filter	Replace with a new filter	6.3
		Air suction in fuel system	Contact KOHLER authorised workshops	--
		Clogged air filter	Replace with a new filter	6.4
		Clogged pipes	Contact KOHLER authorised workshops	--
		Open fuse	Replace with a new fuse	--
		Intake or exhaust system clogged	Contact KOHLER authorised workshops	--
	Engine starts but stops	Inefficient electrical connections	Clean the electrical contacts	--
		Sulphated battery terminals	Clean the battery terminals	--
		Clogged fuel filter	Replace with a new filter and clean the tank	--
	Engine doesn't rev up	Clogged fuel pipes	Contact KOHLER authorised workshops	--
		Safety protocol in starting	Wait some seconds	--
	RPM instability at idle speed	Throttle to MAX in starting	Release the throttle and wait some seconds	--
		Clogged fuel pipes	Contact KOHLER authorised workshops	--
	Low idle speed	Clogged fuel pipes	Contact KOHLER authorised workshops	--
		Poor quality fuel	Clean the tank and refuel with quality fuel	2.5
	Blue smoke	High oil sump level	Replace the engine oil	--
		Clogged air filter	Replace with a new filter	6.4
	Excessive fuel consumption	Clogged air filter	Replace with a new filter	6.4
		High oil sump level	Replace the engine oil	--
	Engine lost its initial performance	Clogged air filter	Replace with a new filter	6.3
		Clogged fuel pipes	Contact KOHLER authorised workshops	--
		Cheap fuel	Clean the tank and refuel with quality fuel	--
		High oil sump level	Replace the engine oil	--
	Slow acceleration	Clogged fuel filter	Replace the fuel filter	6.3
	Engine jerking	Clogged fuel pipes	Contact KOHLER authorised workshops	--
	Engine overheats	Insufficient coolant level	Fill up to the level	4.6
		High oil sump level	Replace the engine oil	--
		Clogged radiator	Clean the radiator	--

- In the event that the solutions proposed in Tab. 7.2 do not eliminate the trouble, contact a KOHLER authorized workshop.

WARRANTY INTERNATIONAL
3 YEAR LIMITED WARRANTY - KOHLER DIESEL ENGINES

Kohler Co. warrants to the original retail consumer that each new Diesel engine will be free from manufacturing defects in materials or workmanship in normal service for the applicable coverage period set forth below beginning on the date of purchase; provided the engine is operated and maintained in accordance with Kohler Co.'s instructions and manuals. If no hour meter is installed as original equipment then 4 hours of use per day and 5 days per week will be used to calculate hours used.

ENGINE SERIES	WARRANTY PERIOD	OPERATING HOURS	WARRANTY COVERAGE
Diesel (non KDI)	3 Years	0 – 2.000	100% Parts & Labor
KDI	3 Years	0 – 2.000	100% Parts & Labor
		2.001 – 6.000	Major Components Only *

* Major component defects are failures related to a crankcase casting, cylinder head casting, crankshaft, crankshaft pulley, camshaft, connecting rod, flywheel, and oil pump.

Kohler Co.'s obligation under this warranty is expressly limited, at its option, to an appropriate adjustment, repair or replacement of such part or parts as found to be defective following an inspection by Kohler Co. or an authorized service facility designated by Kohler Co.

EXCLUSIONS

The following items are not covered by this warranty.

- Damage caused by: (i) an accident or casualty; (ii) unreasonable use or neglect; (iii) normal wear; (iv) premature wear from improper maintenance; (v) improper storage; (vi) old or contaminated fuel left within the fuel system, which includes but is not limited to tanks, fuel lines, or fuel injection components.
- Failures caused by: (i) faulty repairs made by any party other than Kohler Co. or an authorized service facility designated by Kohler Co.; (ii) use of non-Kohler replacement service parts; or (iii) an act beyond the control of Kohler Co., which includes but is not limited to theft, vandalism, fire, lightning, earthquake, windstorm, hail, volcanic eruption, flood or tornado.
- Transportation charges in connection with the repair or replacement of defective parts.
- Engine accessories such as fuel tanks, clutches, transmissions, power drive assemblies, and batteries, unless supplied or installed by Kohler Co.
- Rental of equipment during performance of warranty repairs.
- Fuel, lubricating oil, air filters, oil filters, or coolant/antifreeze

IMPLIED OR STATUTORY WARRANTIES, INCLUDING THOSE OF MERCHANTABILITY AND FITNESS FOR A PARTICULAR PURPOSE, ARE EXPRESSLY LIMITED TO THE DURATION OF THIS WRITTEN WARRANTY. KOHLER CO. MAKES NO OTHER EXPRESS WARRANTY, NOR IS ANYONE AUTHORIZED TO MAKE ANY ON KOHLER CO.'S BEHALF. KOHLER CO. AND/OR THE SELLER SHALL NOT BE LIABLE FOR SPECIAL, INDIRECT, INCIDENTAL, OR CONSEQUENTIAL DAMAGES OF ANY KIND.

Some states or countries do not allow limitations on how long an implied warranty lasts, or the exclusion or limitation of incidental or consequential damages, so the above limitation or exclusion may not apply to you. This warranty gives you specific legal rights, and you may also have other rights which vary from country to country (www.kohlerengines.com), or state to state within U.S.A.

TO OBTAIN WARRANTY SERVICE

Original retail purchaser must bring the engine to an authorized service facility designated by Kohler Co. found by visiting www.kohlerengines.com or telephone 1-800-544-2444 (U.S.A. and Canada).

ENGINE DIVISION, Kohler Co., Kohler Wisconsin

WARRANTY NORMS EPA

KOHLER CO.

CALIFORNIA AND FEDERAL EMISSION CONTROL WARRANTY STATEMENT YOUR WARRANTY RIGHTS AND OBLIGATIONS

The California Air Resources Board, U.S. Environmental Protection Agency (“EPA”) and Kohler Co. are pleased to explain the emission control system warranty on your MY2014-2016 engine. In California (“the State”) and US EPA regulated applications, new heavy-duty off-road engines must be designed, built and equipped to meet the State's and U.S EPA’s stringent anti-smog standards. Kohler Co. must warrant the emission control system on your engine for the periods of time listed below provided there has been no abuse, neglect or improper maintenance of your engine.

Your emission control system may include parts such as the fuel injection system and the air induction system. Also included may be hoses, belts, connectors and other emission-related assemblies.

Where a warrantable condition exists, Kohler Co. will repair your heavy-duty off-road engine at no cost to you including diagnosis, parts and labor.

MANUFACTURER'S WARRANTY COVERAGE

The MY2014-2016 heavy-duty off-road engines are warranted for the periods listed below. If any emission-related part on your engine is defective, the part will be repaired or replaced by Kohler Co.

MY2014-2016 KD, KDW AND ALL TPEM ENGINES	
ENGINE POWER	DURATION
kW < 19 (hp < 25)	3 years or 2,000 hours
kW ≥ 19 (hp ≥ 25)	5 years or 3,000 hours

MY2014-2016 KDI ENGINES	
ENGINE POWER	DURATION
kW < 19 (hp < 25)	3 years or 6,000 hours
kW ≥ 19 (hp ≥ 25)	5 years or 6,000 hours

OWNER'S WARRANTY RESPONSIBILITIES

1. As the off-road engine owner, you are responsible for the performance of the required maintenance listed in your owner's manual. Kohler Co. recommends that you retain all receipts covering maintenance on your off-road engine, but Kohler Co. cannot deny warranty solely for the lack of receipts or for your failure to ensure the performance of all scheduled maintenance.
2. As the off-road engine owner, you should however be aware that Kohler Co. may deny you warranty coverage if your off-road engine or a part has failed due to abuse, neglect, improper maintenance or unapproved modifications.
3. Your engine is designed to operate on diesel fuel only. Use of any other fuel may result in your engine no longer operating in compliance with California's emissions requirements.
4. You are responsible for initiating the warranty process. The ARB suggests that you present your off-road engine to a Kohler Co. dealer as soon as a problem exists. The warranty repairs should be completed by the dealer as expeditiously as possible.

If you have any questions regarding your warranty rights and responsibilities, you should contact Kohler Co., by visiting www.kohlerengines.com or telephone 1-800-544-2444 (U.S.A. and Canada).

COVERAGE

Kohler Co. will repair or replace emission control system parts, components and sub-assemblies found to be defective with respect to materials or workmanship at no cost to you including engine exhaust system related diagnosis, labor and parts. The choice and responsibility of the decision to repair or replace an emission control system defect will be solely that of Kohler Co. Emission control system parts/ components covered by the Federal and California Emission Control Systems Limited Warranty are listed below

- Fuel injector(s)
- Injection pump(s)
- Exhaust manifold
- Intake manifold
- Exhaust gas recirculation (EGR) tube
- Crankcase ventilation valve
- Electronic control unit (ECU) if equipped
- Sensors associated with ECU operation
- Emission control information labels
- Turbocharger (if equipped)
- Fuel limiting device

Parts/components that are scheduled to be replaced as part of the required maintenance schedule will be covered under the warranty provisions for a period of time up to the first scheduled replacement point for the subject parts/ components. Subsequent damage to other engine components as a direct result of a warrantable failure an exhaust emission part/ component will be covered under the warranty provisions described herein.

As the heavy-duty off-road engine owner, you should however be aware that Kohler may deny you warranty coverage if your heavy-duty off-road engine or a part has failed due to abuse, neglect, improper maintenance or unapproved modifications. Only due to the above reasons, the manufacturer may deny the warranty coverage.

A	Alternator:	A component that transforms mechanical energy into AC electrical energy.
	Authorised workshop:	Kohler authorised service centre.
B	Bore:	Internal diameter of the cylinder in combustion engines.
C	Catalyst:	A device in charge of filtering exhausted gas.
	Combustion:	Chemical reaction of a mixture composed of fuel and fuel (air) inside a combustion chamber.
	Common Rail:	A high-pressure "Common Duct" that produces a constant supply of fuel directly to the injectors.
D	DCU:	Dosing Control Unit - It is a control unit that checks the SCR system adjusting the AdBlue dosage inside the SCR catalytic converter according to the parameters detected by the different sensors.
E	EC:	European Community.
	ECS:	Emission Control System
	ECU:	Electronic Control Unit; an electronic device in charge of electronically detecting and controlling other electronic control devices.
	EGR Cooler:	Recirculated exhaust gas cooling; a system that is able to cool recirculated gas (EGR) from the exhaust. This enables the temperature to remain constant inside the intake manifold, thus improving combustion inside the cylinders and breaking down pollutants further.
	EGR:	Exhaust Gas Recirculation, in internal combustion engines; a system that enables recirculation of combusted gas by means of taking it in once again, which enables it to break down a part of the pollutants present in the exhaust gas.
	Electronic injector:	An electronically activated component able to inject jets of atomised fuel inside the cylinders.
	EPA:	Environmental Protection Agency. The United States' authority that safeguards the environment; its duty is to govern and control polluting emissions.
F	Fig.:	Figure.
G	Galvanised:	Material that has undergone surface protection treatment.
H	Heavy conditions:	Type of extreme condition referred to the work environment in which the engine is used (very dusty - dirty area, or in a contaminated environment due to various types of gas).
I	Intercooler:	Air-cooling element under pressure from the turbo situated between the turbine and intake manifold.
K	KDI:	Kohler Direct Injection
M	Maintenance - periodic:	A group of maintenance actions that have the sole objective to control and replace elements on their expiry, without modifying or improving the functions carried out by the system, neither increasing the value nor improving performance.
	MAX:	Maximum.
	Methyl ester	It is a mixture of products by means of a chemical conversion of oils and animal and/or vegetable fat, which is used to produce Biofuel.
	Min.:	Minutes.
	MIN:	Minimum.
	Model:	Model, engine identification plate, which indicates the engine's model.
O	Oil Cooler:	Small radiator used to cool the oil.
P	Par.:	Paragraph.
	Paraffin:	Fatty and solid substance that may form inside the diesel.
	Poly-V:	Poly-V, the name associated with a service belt, which derives from the profile of its section that is constructed with joined Vs.

R	Ref.:	Reference.
S	SCR:	Selective Catalytic Reduction
	s/n:	Serial number (engine identification name plate) indicating the engine identification series/chassis number.
	Spec.:	Specification, (engine identification name plate) indicating the engine version.
T	Tab.:	Table.
	TCR:	Turbo Common Rail.
	Tightening torque:	A term indicated for installation of threaded components and which is determined by means of a unit of measurement Nm.
	T-MAP:	T-MAP (sensor), measures the temperature and absolute pressure inside the intake collector.
	Turbocharger:	Device that compresses air intake by sending it to the intake manifold by means of a turbine.
U	Used oil:	Oil altered by operation or time, which is no longer compliant for correct lubrication of the components.
W	Waste-Gate valve:	A device, which is directly or automatically controlled, used to limit the pressure of exhaust gas inside the turbine.

SYMBOLS AND UNITS OF MEASUREMENT			
SYMBOL	UNIT OF MEASUREMENT	DESCRIPTION	EXAMPLE
α	degree	Rotation/inclination angle	1°
cm ²	square centimetre	Area	1 cm ²
∅	millimetre	Circumference	∅ 1 mm
Nm	newton-metre	Torque	1 Nm
mm	millimetre	Length	1 mm
µm	1/1000 of a millimetre (micron)		1 µm
h	hour	Time	1 h
g/kWh	grammes per kilowatt per hour	Specific consumption	1 g/kWh
kg/h	kilogramme per hour	Max. flow rate	1 kg/h
Lt./min.	litres per minute	Flow rate	1 Lt./min.
Lt./h	litres per hour		1 Lt./h
ppm	parts per million	Percentage	1 ppm
N	newton	Force	1 N
A	Ampere	Intensity of electrical current	1 A
gr.	gramme	Weight	1 gr.
kg	kilogramme		1 kg
W	Watt	Power	1 W
kW	kiloWatt		1 kW
pa	pascal	Pressure	1 pa
KPa	Kilopascal		1 KPa
bar	barometric pressure		1 bar
mbar (1/1000 bar)	barometric pressure		1 mbar
R	Resistance	Resistance to electrical current (referred to a component)	1 Ω
Ω	ohm	Resistance of electrical current	1 Ω
Rpm	revs per minute	Rotation of an axis	1 Rpm
Ra	average roughness expressed in microns	Roughness	Ra = 1
°C	degree centigrade	Temperature	1°C
V	Volt	Electrical voltage	1 V
⬡	millimetre	Hex-head capscrew	⬡ 1 mm
cm ³	cubic centimetre	Volume	1 cm ³
Lt.	litre		1 Lt.

KOHLER[®]

IN POWER. SINCE 1920.

Lombardini s.r.l. is a part of Kohler Group. Lombardini has manufacturing facilities in Italy, Slovakia and India and sales subsidiaries in France, Germany, UK, Spain and Singapore. Kohler/Lombardini reserves the right to make modifications without prior notice.
www.lombardini.it

DEUTSCHLAND

Lombardini Motoren GmbH
Fritz-Klatte-Str. 6, Bürogebäude 2
D – 65933 Frankfurt
Hessen, DEUTSCHLAND
T. +49-(0)69-9508160
F. +49-(0)69-950816-30

EUROPE

Lombardini Srl
Via Cav. del lavoro
A. Lombardini n° 2
42124 Reggio Emilia, ITALY
T. +39-(0)522-389-1
F. +39-(0)522-389-503

UK

Lombardini U.K. Ltd
1, Rochester Barn - Eynsham Road
OX2 9NH
Oxford, UK
T. +44-(0)1865-863858
F. +44-(0)1865-861754

USA & CANADA

Kohler Co.
444 Highland Drive,
Kohler - Wisconsin (53044), US
T. +1 920 457 4441
F. +1 920 459 1570

ESPAÑA

Lombardini ESPAÑA, S.L.
P.I. Cova Solera 1-9
08191 - Rubí (Barcelona)
ESPAÑA
T. +34-(0)9358-62111
F. +34-(0)9369-71613

FRANCE

Lombardini France S.a.s.
47 Allée de Riottier,
69400 Limas, FRANCE
T. +33-(0)474-626500
F. +33-(0)474-623945

CHINA & ROAPAC

Kohler China INVESTMENT Co. Ltd
no.158, Jiang Chang San Road,
200436, Zhabe, Shanghai
CHINA
Tel: +86 400-0120-648
Fax: +86 21 61078904