

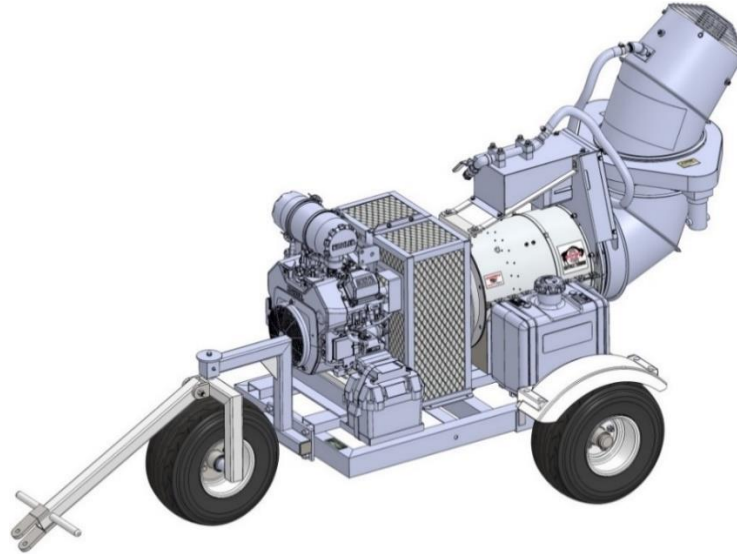

180 Zoar Valley Road • Springville, NY 14141 • Tel: (716) 592-2700 • Fax: (716) 592-2460 • BuffaloTurbine.com



Dust/Odor Controller Gas Model # BT-MGC3EFI

Misting System	Gyratory Atomizing Nozzle
Hose Input	3/4" Utility / Garden Hose
Minimum Water Volume	1/3 Gallon Per Minute
Maximum Water Volume	20 Gallons Per Minute @ 120 psi
Minimum Water Pressure	40 psi
Maximum Water Pressure	120 psi
Droplet size	50-200 Microns
Throw Distance Horizontal	Up to 125 ft. in Neutral Wind Conditions
Throw Distance Vertical	Up to 50 ft. in Neutral Wind Conditions
Warranty	10 Year Manufacturer Warranty
Motor Warranty	3 Year Engine Warranty
Input Power	26.5 HP Engine
Outlet Size	12"
Oscillation	Settings up to 270°
Frame Length	48"
Overall Length with Nozzle	126" (105" with handle turned to side for transporting)
Length without wheels and handle	76"
Width	48" (34" with wheels and handle removed)
Max Height with nozzle in upright position	58"
Weight	Approx. 800 lbs.
Transmitter	Hand held wireless transmitter (water resistant) with push button control
Control	12 V Wireless system w/ remote engine start /stop (no choke required), 360° Nozzle Control and Throttle Control



WARNING: Cancer and Reproductive Harm – www.P65Warnings.ca.gov