

# BLITZ BT-SB26 Service Manual



## Contents:

### Introduction and Safety:

Introduction and Product Identification .....	1
Operational Safety and Guidelines .....	2

### Maintenance Overview

Lifting and Hoisting the Machine .....	7
Disconnecting and Connecting the Battery .....	9

### Maintenance Procedures

Auxiliary Port.....	9
Control Panel Toggle Switch .....	9
Ignition Switch.....	10
Hour Meter .....	10
Throttle Control .....	10
Parking Brake Switch.....	11
Headlight .....	11
Nozzle Rotation Harness or Button.....	12
Nozzle Rotation Motor.....	13
Fuel Transfer Valve.....	14
Fuel Tank .....	15
Nozzle Rotation V-Belt .....	15
Base Ring or Base Ring Bearings .....	16
Yoke or Front Wheel .....	16
Front Shock/Spring.....	17
Rear Shock/Spring.....	18
Reversing Contactor.....	18

### Advanced Replacement Procedures

26HP Engine Replacement.....	20
------------------------------	----

## Introduction and Product Identification

This service manual provides detailed instructions for the maintenance, troubleshooting and repair of the **BLITZ BT-SB26 Stand-On Debris Blower**. Use this manual as a guide to ensure efficient and reliable operation of your equipment.

This manual is intended for personnel capable of the service that will be performed in this manual. Keep this manual accessible for reference during maintenance and repairs.

For additional support, contact Buffalo Turbine service department.

### Serial Number Location:

When ordering parts or requesting service or information, always provide your dealer with the serial number of your Debris Blower. The serial number plate [A] is centered on the control panel as shown in the images below. An example of what this tag looks like is shown.

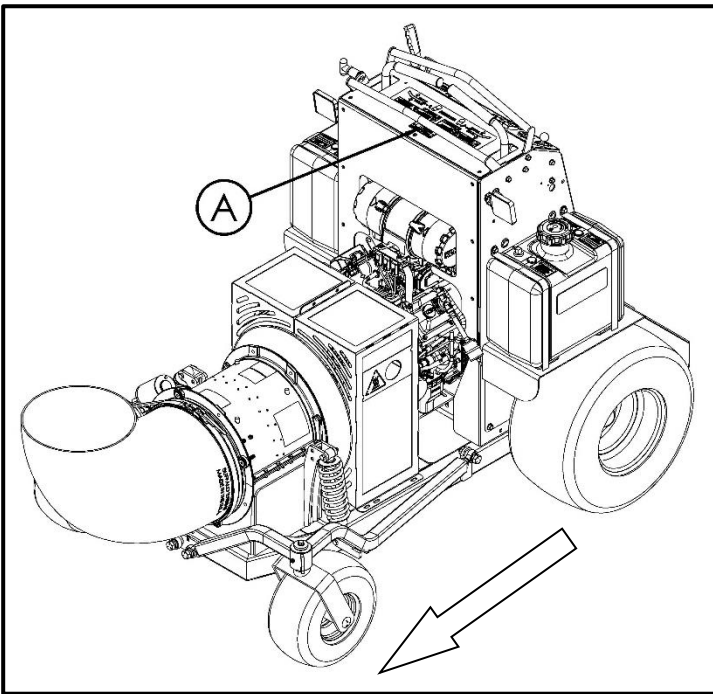

## Operator Orientation:

The terms left, right, front, and rear, as used in this manual, refer to the orientation as viewed from the operator's standing platform, facing the direction of forward travel.

For your records, document your machine's model number, serial number, dealer contact, and purchase date in the space provided below.

Machine Information Record	
<b>Model Number:</b>	
<b>Serial Number:</b>	
<b>Purchase Date:</b>	
<b>Dealer Contact:</b>	



# Operational Safety and Guidelines

## Overview:

This service manual provides safety information and procedures for maintenance of the machine. It outlines precautions and repair methods designed to prevent accidents, injuries, and damage to equipment during service. Users are expected to be familiar with all safety precautions and adhere to recommended procedures throughout the service process.

For general operation, routine maintenance, and safety practices, refer to the operator's manual for this machine.

For your safety and the safety of others, always adhere to the guidelines provided in this manual and comply with local regulations related to equipment use.

## Understanding Safety Symbols and Terms

### Attention! Your Safety is Involved!

The Safety Alert symbol is used to indicate important safety messages throughout this manual and on the machine itself. When you see this  symbol, pay immediate attention to the potential for personal injury or death. Follow all safety instructions closely.

Signal Words Used in This Manual:

 **DANGER** – Indicates an immediate hazard that, if not avoided, will result in serious injury or death.

 **WARNING** – Identifies a specific hazard or unsafe practice that could lead to severe injury or death if not followed correctly.

 **CAUTION** – Highlights unsafe practices that could result in minor injury or serves as a reminder for safe practices.

**Note** – Provides important information or instructions to clarify steps or provide additional context, similar to a notice.

**Optional** – Identifies steps, components, or actions that are not required to complete the task but may offer additional benefits.

**Recommendation** – Advises steps or actions to prevent avoidable or inconvenient issues, enhancing safety or operational efficiency.

## Why Safety Matters

- Accidents can cause serious injury or death.
- Accidents are costly and disrupt operations.
- Accidents can be prevented by following proper safety procedures.

## California Proposition 65



**WARNING** This product can expose you to chemicals which are known to the State of California to cause cancer and birth defects or other reproductive harm. For more information, go to [www.P65Warnings.ca.gov](http://www.P65Warnings.ca.gov)

## Safety and Training

As the owner, **YOU** are responsible for the safe operation and maintenance of your Buffalo Turbine Debris Blower. Ensure that everyone who operates, maintains, or works around this equipment is fully familiar with the procedures and safety information provided in this manual.

## Safety Starts with You

Implementing safe practices not only protects you but also protects those around you. Make safety a standard part of your operations, and ensure everyone using the machine understands and follows the necessary precautions. Most accidents are preventable—never ignore safety practices.

- Ensure all operators and mechanics read the operator's manual and other training materials thoroughly. If they cannot read English, the owner must explain the material to them.
- Ensure all users understand the machine's controls, safety signs, operating procedures and emergency protocols.
- Allow only trained users to operate the machine. Do not permit children or untrained individuals to use or service the equipment. Follow local age restrictions and regulations.
- Never modify the machine or any of its components. Unauthorized modifications can compromise safety and reduce the equipment's functionality and lifespan.
- The owner or user is responsible for preventing accidents or injuries to themselves, others, and property. Ensure the equipment is in proper working condition before each use.

**Think Safely! Work Safely!** By incorporating these practices, you contribute to a safer working environment and reduce the risk of accidents or injuries.

## Personal Protective Equipment (PPE)

Users must wear appropriate personal protective equipment (PPE), including a hard hat, safety glasses, hearing protection, and slip-resistant footwear. Secure long

hair and avoid wearing loose clothing or jewelry that could become entangled in moving parts.

## Operating Safely

- Always inspect the blower, bolts, and connections to the blower for wear or damage.
- Never run the engine in an enclosed area to avoid carbon monoxide buildup.
- **DO NOT** operate the machine under the influence of alcohol or drugs.
- **DO NOT** wear headphones or listen to music while operating the unit.
- Ensure motion control arms are in the neutral position before starting the engine.
- Keep hands, feet, and other body parts away from the intake and discharge area.
- **DO NOT** aim blower discharge at people or animals.
- Stop and inspect the machine if unusual vibrations occur.
- Stop the machine on level ground, engage the parking brake, and shut off the engine before leaving the operator's platform.
- Drive backward when ascending slopes and forward when descending to maintain control and stability.
- Slow down when making turns, crossing roads, or approaching blind corners.
- Look behind and down before backing up to ensure a clear path.
- Never allow passengers on the machine and keep pets and bystanders away.
- Load the machine onto trailers or trucks in reverse for safer handling.
- Remove the key when the machine is unattended, stored, or parked to prevent unauthorized use.

## Parking the Machine

1. Stop the machine on level ground and ensure the motion control arms return to the neutral position.
2. Turn off the machine, engage the parking brake, and remove the key from the ignition.
3. Confirm all moving parts have stopped before stepping off the operator's platform.

## Prevent Fires

Gasoline is highly flammable and should be handled with extreme caution to prevent personal injury or property damage:

- Allow the engine to cool for at least 3 minutes before refueling. Never refuel the machine while the engine is running.
- **DO NOT** permit open flames, smoking, or matches in the vicinity while handling fuel.
- Avoid overfilling the fuel tank, and clean up any spills immediately. If fuel is spilled near the unit, do not start the engine until the spill is cleaned and vapors have dissipated.
- Use a clean, approved non-metallic container to prevent static discharge. Never fill containers inside a vehicle or on a truck or trailer bed; always place containers on the ground away from the vehicle before adding fuel.
- Always use a clean, approved non-metallic funnel equipped with a plastic mesh strainer when refilling the fuel tank.
- Store fuel in an approved container away from any open flame, spark, or pilot light, such as those on water heaters or appliances.
- Avoid using gasoline with methanol; it is harmful to both health and the environment.
- Keep the fuel nozzle in contact with the rim of the fuel tank or container opening while fueling, and do not use a nozzle lock open device.

## Managing Spilled Fluids and Proper Disposal

When performing inspection, maintenance, testing, adjustment, or repair of the machine, ensure that all fluids are properly contained. Be prepared to collect fluids with suitable leakproof containers before opening or disassembling any component that contains fluids. In the event of a spill, immediately contain the spill using absorbent materials, and clean the area thoroughly to prevent slipping hazards or damage to the machine.

Never pour waste fluids onto the ground, down a drain, or into any source of water, as improper disposal can harm the environment. Collected waste, including used absorbent materials and contaminated fluids, should be placed in designated, clearly labeled containers and disposed of according to local regulations and mandates. Use a licensed waste disposal service to ensure proper handling of hazardous materials. Always wear appropriate personal protective equipment (PPE) when handling fluids and during the disposal process to protect yourself and maintain a safe work environment.

## Tire and Wheel Safety

 **WARNING** Improper handling of tire and rim assemblies can result in serious injury or death.

- Always maintain the correct tire pressure and never exceed the recommended pressure in *Machine Specifications*.
- **DO NOT** mount a tire without proper equipment and experience.
- Never weld or heat a wheel and tire assembly; this can cause an explosion or weaken the wheel.
- When inflating tires, use a clip-on chuck and an extension hose that allows you to stand to the side, away from the front or top of the tire assembly.
- Regularly inspect rear wheel hardware and tighten to 90 ft-lbs (122 N·m) using the proper procedure, especially during the first 100 hours of operation.

## Maintenance

- Engage the parking brake, stop the engine, and remove the key before adjusting, cleaning, or repairing. Wait for all movement to stop before proceeding.
- Clean all debris from the machine to prevent fire hazards and clean up any oil or fuel spills immediately.
- Use properly rated jack stands to securely support machine when performing maintenance.
- Release pressure from the transaxles by moving the control levers back and forth with the engine off.
- Keep hands, feet, clothing, jewelry, and long hair away from moving parts.
- Charge the battery in a well-ventilated area away from sparks or flames. Unplug the charger before connecting or disconnecting it from the battery. Wear protective clothing and use insulated tools.
- Regularly check and tighten all hardware, including blower attachment bolts, to ensure the equipment is in safe working condition. Replace worn or damaged components and decals as needed.
- Frequently check parking brake operation to ensure proper functionality.

## Storing the Machine

- Store the machine away from areas of frequent use. Do not allow children to play on or around the stored machine.

- Ensure the machine is on a firm, level surface and securely blocked to prevent it from tipping or sinking into soft ground.
- Cover the machine with a weatherproof cover and secure it tightly to protect it from the elements.
- Allow the engine to cool before storing, and do not store near any open flames or heat sources.
- Never store fuel near open flames or heat sources.
- **DO NOT** drain fuel indoors; always drain in a well-ventilated outdoor area.
- Release pressure from the transaxles by moving the control levers back and forth with the engine off.

## Blower Dangers

 **WARNING** Rotating blower blades can cause severe injury, including amputations, and can also eject debris at high speeds. Adhering to the following safety guidelines is crucial to prevent serious injury or death:

- Keep hands, feet, and clothing away from the blower housing when the engine is running.
- Inspect the blower only when the engine is off and all movement has completely stopped.

## Prevent Tipping

Before operating on slopes, use the Slope Guide to ensure the grade does not exceed 15°. Operating on slopes greater than 15° significantly increases the risk of loss of control, tip-over, and severe injury or death. Always evaluate the slope carefully and follow all safety precautions.

- **DO NOT** drive forward up slopes or backward down slopes; the machine's rear-heavy design increases the risk of tipping when operated outside the recommended.
- Use low speeds on slopes to maintain control and prevent sudden stops or traction loss.
- Keep movements slow and gradual, avoiding sudden changes in speed or direction.
- Avoid turning while driving perpendicular to slopes; always exit the slope using the smoothest, most gradual path possible.
- Load the machine onto trailers or trucks in reverse for safer handling.

## Stickers

Safety stickers and icons on the machine show essential warnings and instructions. Operators must know their locations and meanings, as these symbols highlight hazards and safe operating practices. Regularly check that decals are intact and legible.

 **WARNING** Replace any that are missing or damaged to ensure continued safety.

### Sticker Identification

- Operator Tower Decal: [A]
- Guard Requirement Decal: [B]
- Combined Warning Decal: [C]

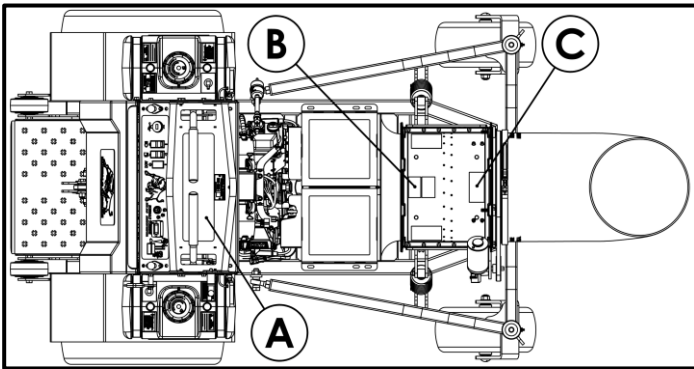

### Operator Tower Decal, Part Number: 5041



### Guard Requirement Decal, Part Number: 1186



### Combined Warning Decal, Part Number: 4725



	Indicates important cautions or warnings that <b>MUST</b> be followed.
	Wear hearing protection to prevent hearing loss.
	Wear eye protection to prevent injury.
	<b>WARNING</b> Thrown objects can cause serious injury.
	<b>DO NOT</b> refuel with engine running or with hot engine.
	Read and understand the Owner's Manual before operation. Be sure you know all sections with an emphasis on safety and operation.
	Keep clear of all moving and hot parts. Keep all guards in place during operations.
	Keep unit clean and free of debris, especially around exhaust. Failure to do so can cause fire.
	Use extreme caution when operating on slopes. Always use slow deliberate movements avoiding high speed or sudden movements.



# Lifting and Hoisting the Machine

## Jack and Support Points:

This diagram illustrates the designated jack points and support points for the BT-SB26 to ensure proper lifting and stabilization during maintenance.

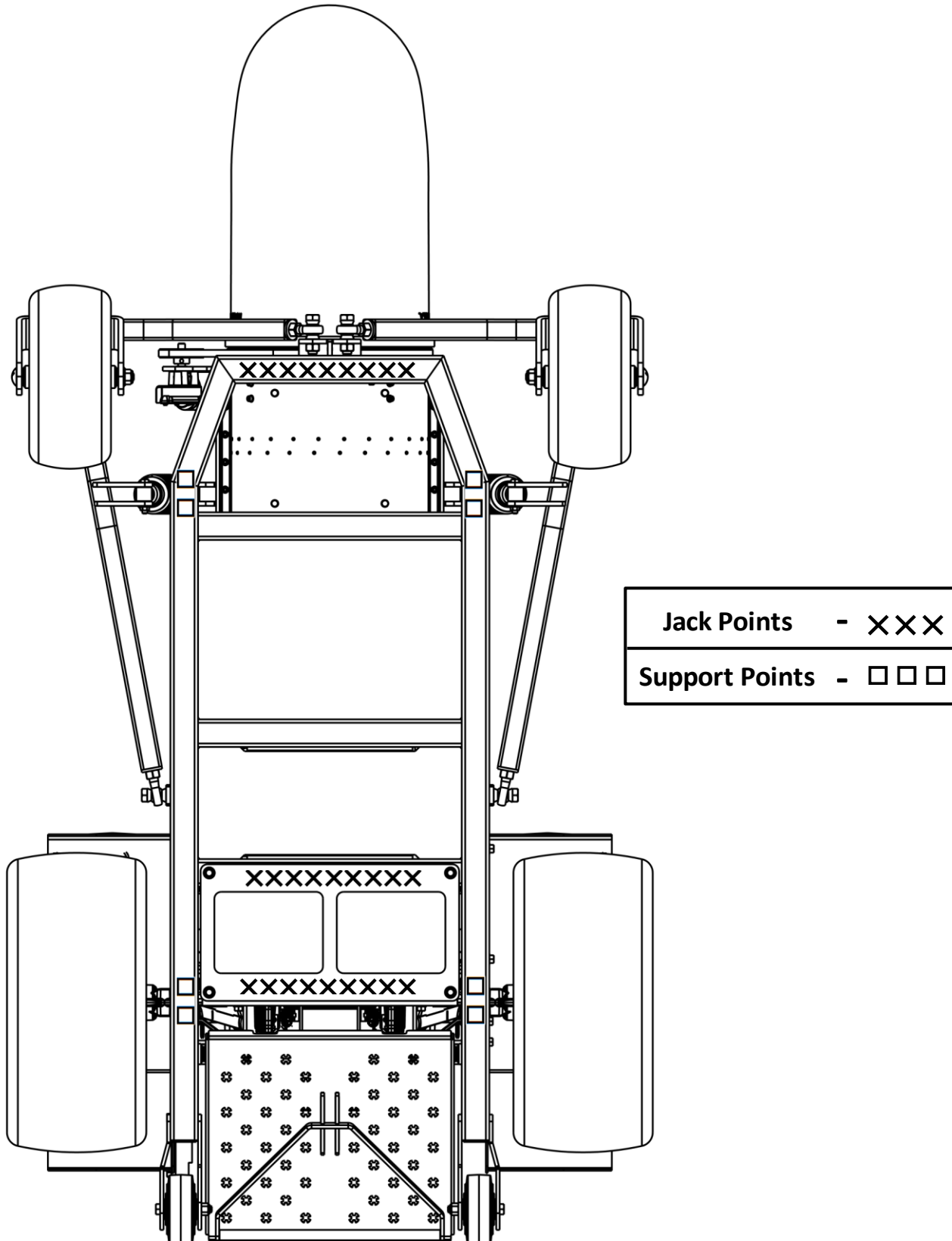

## Hoist Pick-Up Points:

This diagram illustrates the designated hoisting points for the BT-SB26 to ensure proper lifting during maintenance.

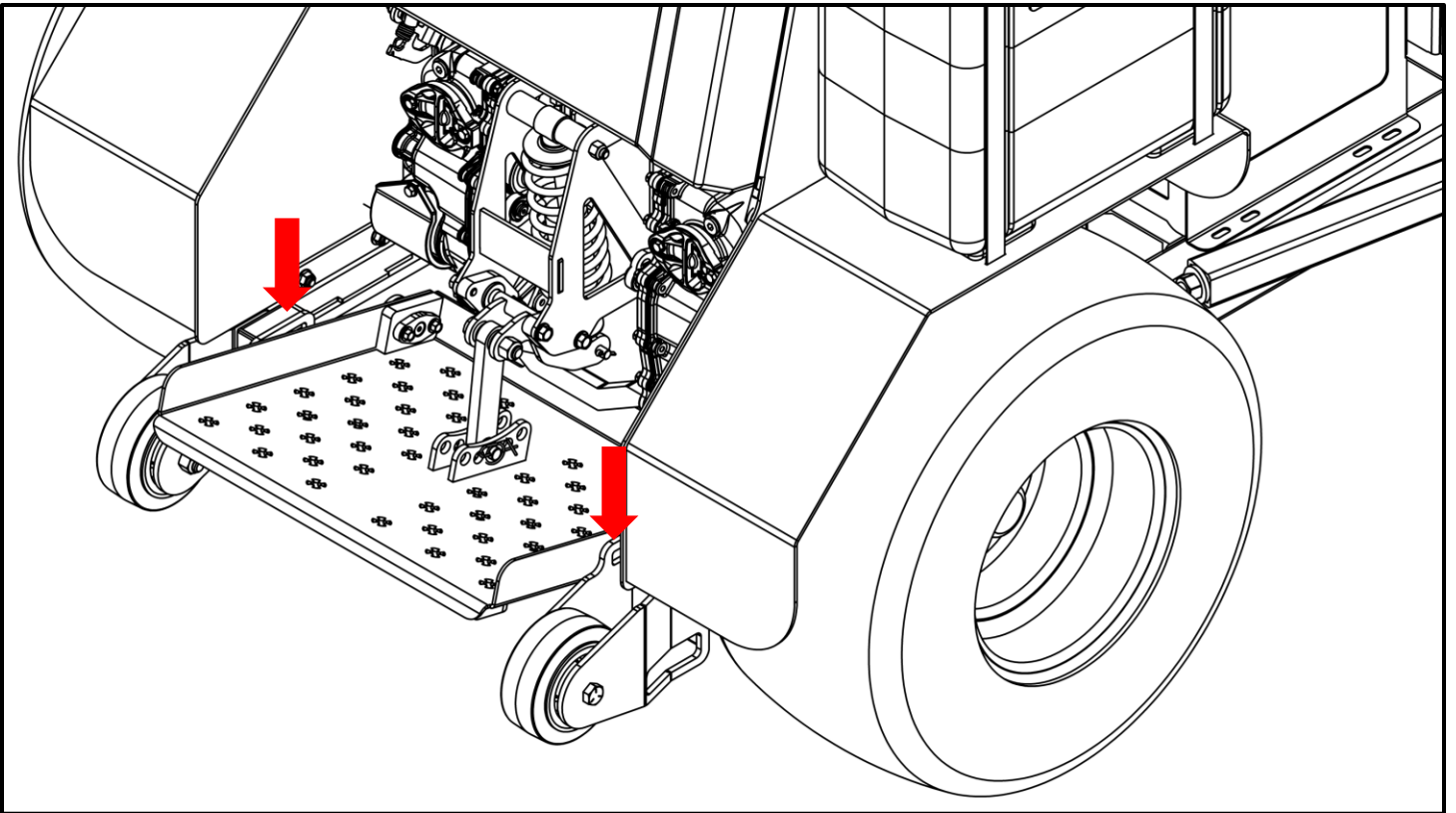
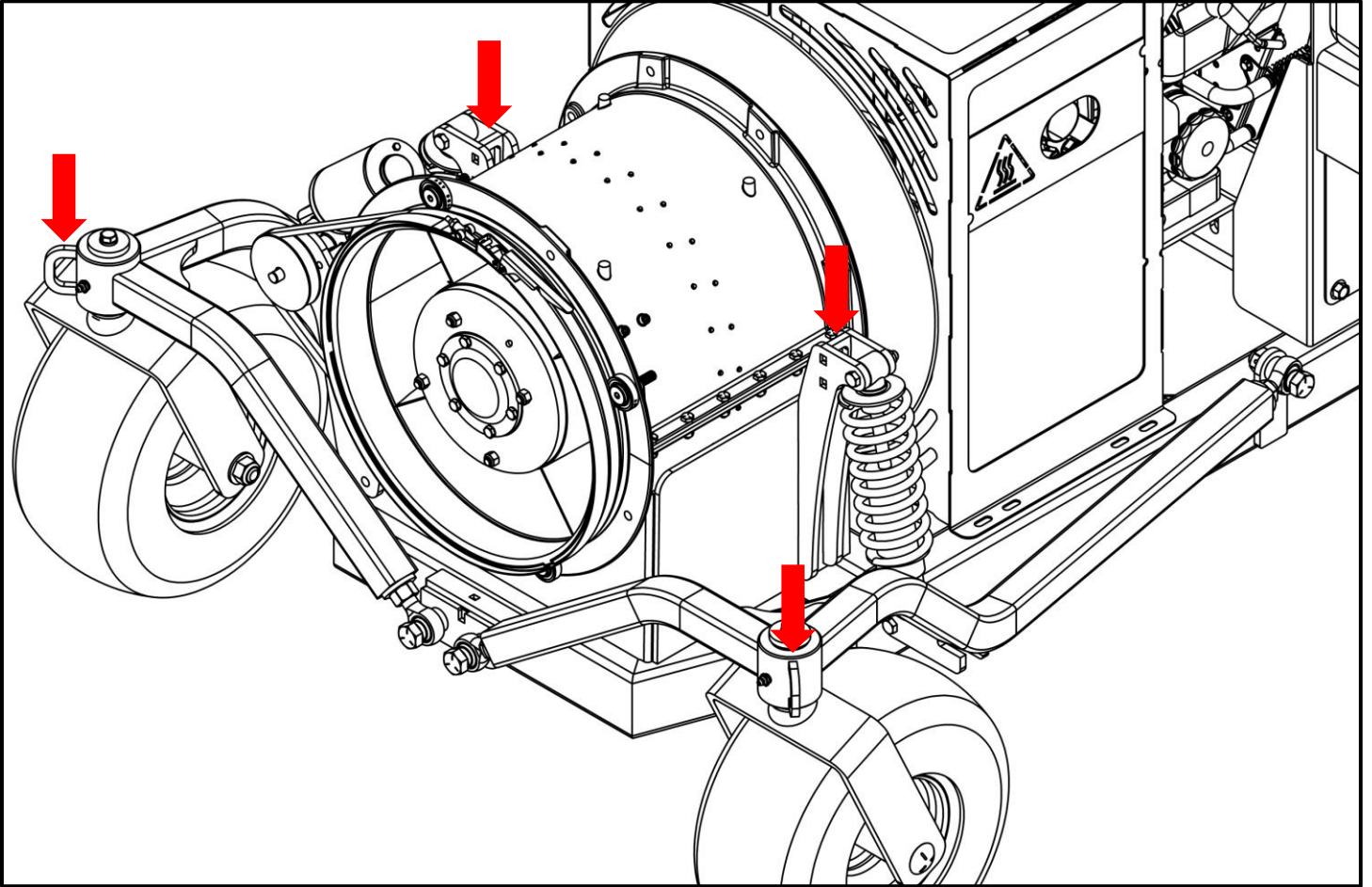

# Disconnecting and Connecting the Battery

## Tool & Supplies:

- 1/2" Socket
- Extension of 6" or more
- Ratchet
- Torque Wrench

## Disconnect

1. Engage the parking brake and remove the key from the ignition.
2. Remove the leaning pad from the machine and set it aside.
3. Remove the nut from the bolt holding the cables to the negative terminal as shown in [Figure 1] using a 1/2" socket, socket-driving wrench, and extension of at least 6".



Figure 1 Removing Negative Terminal from Battery

4. Leave the bolt in the cable ends, pull the cables away from the battery, and reinstall the nut on the end of the bolt.
5. Remove the nut from the bolt holding the cables to the positive terminal using the same tool combination from Step 3.
6. Leave the bolt in the cable ends, pull the cables away from the battery, and reinstall the nut on the end of the bolt. **Ensure** both cables are clear of the battery terminals and each other.

## Reconnect

1. Remove the nut from the bolt in the end of the positive battery cable.
2. Insert the bolt through the positive terminal of the battery and fully thread the nut back onto the bolt.
3. Tighten the nut onto the bolt of the positive terminal using a 1/2" socket, torque wrench, and extension of at least 6". Torque to 15 ft-lbs (20.3 N·m).

4. Remove the nut from the bolt in the end of the negative battery cable.
5. Insert the bolt through the negative terminal of the battery and fully thread the nut back onto the bolt.
6. Tighten the nut onto the bolt of the negative terminal using the same tool combination from Step 3. Torque to 15 ft-lbs (20.3 N·m).

## Auxiliary Port

### Directions:

1. Disconnect the battery. [*Disconnecting and Connecting the Battery*]
2. Disconnect the spade terminals from the underside of the switch.
3. Remove the plastic nut on the underside of the control panel by hand.
4. Pull the existing switch out the top of the control panel.
5. Place new port into the slot of the control panel.
6. Reconnect the spade terminals as shown.

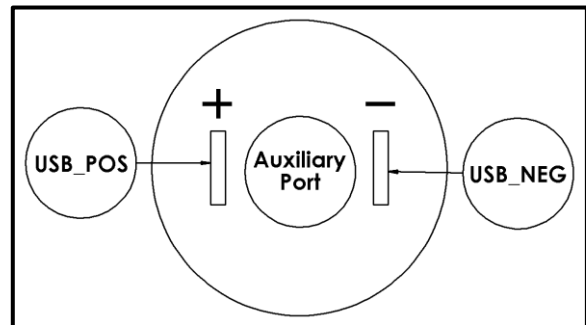

Figure 2 Auxiliary Port Labels

7. Reconnect the battery. [*Disconnecting and Connecting the Battery*]
8. Test auxiliary port and battery voltage display functionality.

## Control Panel Toggle Switch

### Directions:

1. Disconnect the battery. [*Disconnecting and Connecting the Battery*]
2. Disconnect the spade terminals from the underside of the switch.
3. Press the tabs on the short sides of the switch, then pull the existing switch out from the top of the control panel.
4. Place new switch into the slot on the control panel.

5. Reconnect the spade terminals as shown for the toggle switch of interest. [Figure 4, Figure 3]

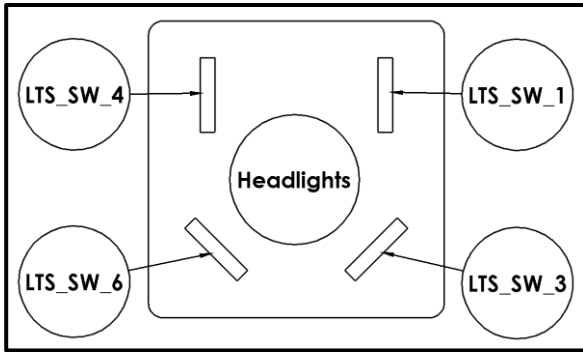

Figure 4 Headlight Toggle Switch Labels

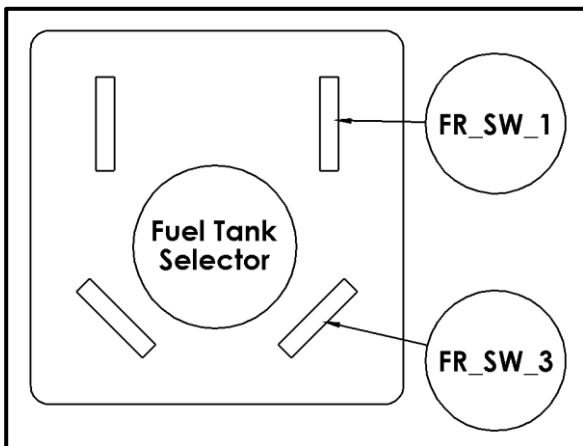

Figure 3 Fuel Tank Selector Switch Labels

6. Reconnect the battery. [Disconnecting and Connecting the Battery]
7. Test toggle switch functionality.

## Ignition Switch

### Tools & Supplies:

- 19mm Wrench

### Directions:

1. Disconnect the battery. [Disconnecting and Connecting the Battery]
2. Disconnect the harness and spade terminal from the underside of the ignition switch.
3. Remove the hex nut, serrated washer and flat washer from the top side of the ignition switch using a 19mm wrench.
4. Push the existing switch out the bottom of the control panel.
5. Place new switch into the slot of the control panel.
6. Rotate the switch so the key slot is aligned along the length of the machine, ensuring the single spade connection on the switch is on the same side as the parking brake handle.

7. Tighten the switch to the control panel.
8. Reconnect the harness plug and spade terminal.
9. Reconnect the battery. [Disconnecting and Connecting the Battery]
10. Test ignition switch functionality.

## Hour Meter

### Tools & Supplies

- PH1 Screwdriver

### Directions:

1. Disconnect the battery. [Disconnecting and Connecting the Battery]
2. Remove the two screws on the face of the hour meter using a PH1 screwdriver.
3. Pull the hour meter signal wire out from the hour meter and not the backing plate. **Note:** Routing of the signal wire.
4. Remove the existing hour meter.
5. Route the signal wire into the new hour meter, following the same path as Step 3.
6. Tighten the hour meter and backing plate to the control panel.
7. Reconnect the battery. [Disconnecting and Connecting the Battery]
8. Test hour meter functionality.

## Throttle Control

### Tools & Supplies:

- 7/16" Wrench
- 3/8" Wrench
- T15 Bit Socket
- Ratchet
- 
- 

### Directions:

1. Disconnect the battery. [Disconnecting and Connecting the Battery]
2. Disconnect the harness plug on the underside of the throttle control.
3. Remove the throttle control grip screw using a T15 bit socket and ratchet.
4. Detach the throttle control from the underside of the control panel using a 7/16" wrench on the hex nut and 3/8" wrench on the bolt head.
5. Remove the existing throttle control from the machine.
6. Tighten the new throttle control to the underside of the control panel.

7. Attach the throttle control and tighten the screw.
8. Connect the harness plug back to the underside of the throttle control.
9. Reconnect the battery. [*Disconnecting and Connecting the Battery*]
10. Test throttle control functionality.

## Parking Brake Switch

### Tools & Supplies:

- 15/16" Wrench
- PH1 Screwdriver
- Wheel Chocks

### Directions:

1. Chock the rear wheels.
2. Disengage the parking brake and remove the key from the ignition.
3. Disconnect the battery. [*Disconnecting and Connecting the Battery*]
4. Remove the upper plastic nut [A] from the parking brake switch [B] using a 15/16" wrench.

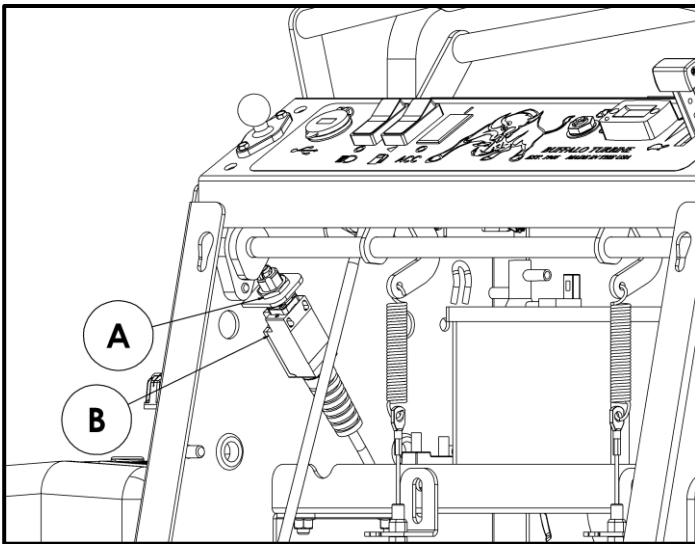

Figure 5 Parking Brake Switch

5. Pull the switch from the bracket.
6. Remove the screws securing the back cover on the switch with a PH1 screwdriver.
7. **Optional:** Take an image of the wire connections to the terminals.
8. Remove the screws securing the wires with a PH1 screwdriver.
9. Loosen the male-male threaded adapter on the flexible sleeve until the switch disconnects from the adapter with a 15/16" wrench.
10. Detach the existing switch from the flexible sleeve.
11. Remove the upper plastic nut [A] on the new switch; do not discard.

12. Match the lower plastic nut on the new switch to the same position as on the old switch to ensure proper fitment on the machine.
13. Remove the back cover on the new switch.
14. Connect the wires to the proper terminals.
15. Tighten the back cover onto the switch.
16. Tighten the new switch to the male-male adapter on the flexible sleeve.
17. Slide the switch into the bracket on the left side panel.
18. Tighten the upper plastic nut on the switch.
19. Reconnect the battery. [*Disconnecting and Connecting the Battery*]
20. Remove the wheel chocks.
21. Test parking brake switch functionality.

## Headlight

### Tools & Supplies:

- (2) 7/16" Wrench
- 9/16" Socket
- Ratchet
- Diagonal Cutting Pliers
- Cable Ties
- Torque Wrench

### Directions:

1. Apply the parking brake and remove the key from the ignition.
2. Disconnect the battery. [*Disconnecting and Connecting the Battery*]

**Note:** Steps 3 & 12 do not apply to **BLITZ BT-SB26**.

3. Cut the (3) cable ties securing the fuel lines to the inside of the front panel.
4. Remove the bolts securing the front panel using a 9/16" socket and ratchet.
5. Remove the front panel.
6. Disconnect the existing headlight spade terminals [C] from the machine harness.
7. Remove the bolt [B] securing the existing headlight assembly [A] to the side panel using (2) 7/16" wrenches.

- Tighten the new headlight to the side panel with the hardware order shown.

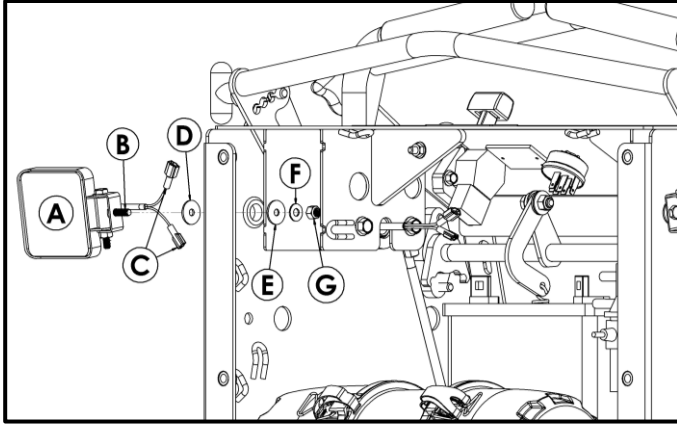

Figure 6 Headlight Hardware Order

- Connect the new headlight spade terminals to the harness.
- Start all bolts on the front panel by hand.
- Torque to 35 ft-lbs (47.5 N·m).
- Cable tie the fuel lines to the same location from Step 3.
- Reconnect the battery. [*Disconnecting and Connecting the Battery*]

## Nozzle Rotation Harness or Button

### Tools & Supplies:

- PH1 Screwdriver
- Silicone
- Short Screwdriver

### Directions:

**Note:** Steps 7, 8, and 10-12 do not apply when replacing the nozzle rotation button.

- Apply the parking brake and remove the key from the ignition.
- Disconnect the battery. [*Disconnecting and Connecting the Battery*]
- Remove foam grip from the motion control handle.
- Push the button out from the slot on the motion control handle using a short screwdriver [Figure 8].



Figure 8 Button Removal Slot

- Pull button out to expose terminals on the back of the button.
- Use a PH1 screwdriver to disconnect the wired connections from the button.
- Disconnect the spade connections from the main harness at the lower end of the motion control arm [Figure 9, Figure 10].

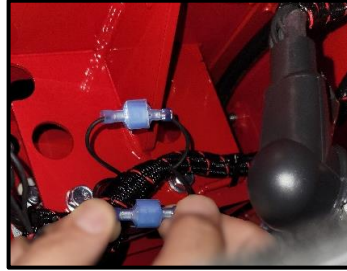

Figure 9 Left Side Motion Control Spade Terminals

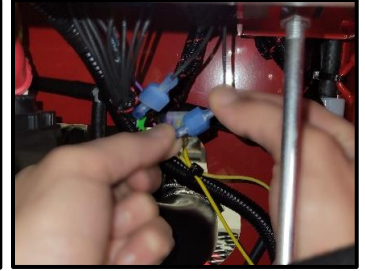

Figure 10 Right Side Motion Control Spade Terminals

- Pull the motion control harness out from the bottom of the motion control arm.
- Clean any silicone residue from the top end of the motion control arm.
- Feed the end of the harness with bare wire up through the bottom of the motion control arm.
- \*If Required\* Push the harness up the motion control arm with a screwdriver.
- Reconnect the spade connections from Step 7.
- \*If Required\* Dispose of the hex nut from the button.
- Reconnect the wires to the terminals on the back of the button as shown. **Note:** Center the wire end under the screw [Figure 7, Figure 11].



Figure 7 Button Terminals



Figure 11 Wires Bent 90°

- Apply silicone to the switch threads.
- Insert the button into the top end of the motion control arm until the hex nut meets the arm.
- Reinstall the hand grip onto the motion control arm.
- Reconnect the battery. [*Disconnecting and Connecting the Battery*]
- Test nozzle rotation functionality.

# Nozzle Rotation Motor

## Tools & Supplies

- 9/16" Socket      • Torque Wrench      • Ratchet
- 7/16" Socket      • 5/32" Hex Bit Socket      • Cable Tie

## Directions:

1. Apply the parking brake and remove the key from the ignition.
2. Loosen but do not remove the bolts [A] holding the rotation motor bracket using a 9/16" wrench.



Figure 12 Rotation Motor Components Map

3. Pivot the rotation motor [B] with the bracket towards the blower to release tension on the V-Belt.
4. Remove the V-Belt [C] from around the rotation motor pulley [D].
5. Rotate the rotation motor pulley until the set screw [E] is visible.

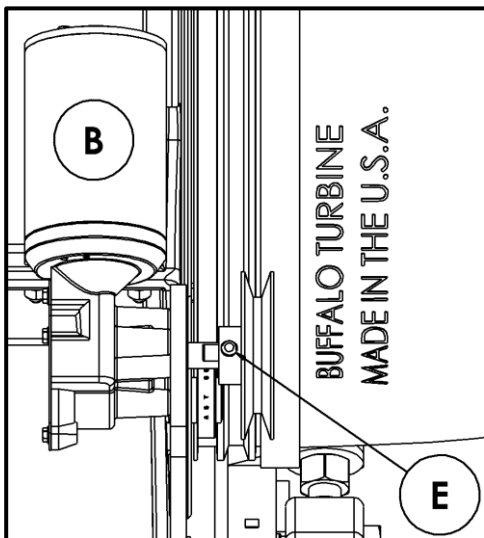

Figure 14 Set Screw in Pulley

6. Back the set screw out until the pulley slides off the rotation motor shaft using a 5/32" bit and ratchet.
7. Disconnect the 2 wired connections to the rotation motor visible behind the rotation motor.
8. Remove the bolts mounting the rotation motor to the rotation motor bracket using a 7/16" wrench.
9. Remove the existing rotation motor.
10. Tighten the hardware to mount the new rotation motor to the rotation motor bracket by hand.
11. Torque to 13 ft-lbs (17.6 N·m) using a 7/16" socket.
12. Connect the 2 wired connections from Step 7.

Rotation Motor Wire		Wire Label
Red		→ FWD
Black		→ REV

13. Secure the wires around the rotation motor with a cable tie. [Figure 13]



Figure 13 Wires Secured to Rotation Motor

14. Place the rotation motor pulley onto the rotation motor shaft with the threaded hole over the flat side of the shaft.
15. Align the face of the pulley to be flush with the end of the rotation motor shaft.
16. Remove the set screw from the pulley.
17. Place a drop of blue Loctite on the threads of the set screw.
18. Thread the set screw into the pulley.
19. Torque to 12 ft-lbs (16.3 N·m).
20. Wipe excess Loctite from the pulley.
21. Attach the V-Belt to the rotation motor pulley.

22. Pivot the rotation motor with the bracket away from the blower to tension the V-Belt.
23. Tighten the bolts from Step 2.
24. Torque to 30 ft-lbs (40.7 N-m).

## Fuel Transfer Valve

### **WARNING**

Gasoline is highly flammable and explosive. You can be burned or seriously injured when handling fuel.

- Stop the engine and keep heat, sparks and flame away.
- Refuel only in a well ventilated area.
- Wipe up spills immediately.

### Tools & Supplies:

- 1/4" Socket
- 7/16" Wrench
- Cable Ties
- 3/8" Wrench
- Torque Wrench
- Marker
- 9/16" Socket
- Masking Tape
- Ratchet
- 3/8" Socket
- Diagonal Cutting Pliers
- Rag

### Directions:

1. Apply the parking brake and remove the key from the ignition.
2. Disconnect the battery. [Disconnecting and Connecting the Battery]
3. Remove the bolts securing the front panel using a 9/16" socket and ratchet.
4. Remove the front panel.
5. **Optional:** Take a photo of the fuel transfer switch and the hoses connected to it for reference.
6. Loosen the hose clamps on the fuel lines with 1/4" socket and ratchet.
7. Slide the hose clamps along the fuel line away from the fuel transfer switch.
8. Place a rag below the fuel transfer switch for when disconnecting fuel lines.
9. **CAUTION:** Repeat the following steps for each fuel line:
  - a. Remove one fuel line at a time by using a pair of pliers to rotate the fuel line on the barb and then pull it off the barb.
  - b. Apply a piece of masking tape with a number written on it according to the map [Figure 16].

10. Remove the hex nut and lock washer using a 3/8" socket and ratchet. [Figure 15]



Figure 15 Removing Positive Wire from Fuel Transfer Switch

11. Disconnect the positive ring terminal from the stud.
12. Remove the bolt securing the negative ring terminal using a 3/8" wrench and 7/16" wrench.
13. Remove the other bolt securing the valve.
14. Remove the existing fuel transfer valve.
15. Tighten the bolt through the negative ring terminal.
16. Tighten the other valve mounting bolt.
17. Torque both bolts to 130 in.lbs. (14.7 N.m.)
18. Reconnect the positive ring terminal from Step 11 to the stud with the hex nut and lock washer.
19. Torque the hex nut to 15 in.lbs. (1.7 N.m.)
20. Reconnect the hoses to their matching barb according to the map [Figure 16].



Figure 16 Labeled Fuel Transfer Switch

21. Slide the hose clamps back over the barbs on the fuel transfer switch.
22. Tighten the hose clamps.
23. Start all bolts on the front panel by hand.
24. Torque to 35 ft-lbs. (47.5 N.m.)
25. Reconnect the battery. [Disconnecting and Connecting the Battery]

## Fuel Tank

### **⚠ WARNING**

Gasoline is highly flammable and explosive. You can be burned or seriously injured when handling fuel.

- Stop the engine and keep heat, sparks and flame away.
- Refuel only in a well ventilated area.
- Wipe up spills immediately.

### Tools & Supplies:

- Fuel Siphon
- Ratchet
- Torque Wrench
- 9/16" Socket
- Pliers
- 9/16" Wrench
- Rags

### Directions:

1. Disconnect the battery. [*Disconnecting and Connecting the Battery*]
2. Remove the fuel tank cap. \*Do Not Discard\*
3. **CAUTION:** Siphon the fuel tank into an approved  container.
4. Remove bolts securing each fuel tank strap to the side panel of the machine using a 9/16" socket, ratchet, and 9/16" wrench. **Note:** Hex nut is on the battery side of the side panel.
5. Position the straps out of the way, allowing for fuel tank removal.
6. Slide the hose clamps off the barb and down the fuel line using a pair of pliers.
7. Place rags around the fuel tank bars.
8. Disconnect the fuel lines from each barb fitting on the fuel tank.
9. Remove the existing fuel tank from the machine.
10. Place new fuel tank on the machine fender with the barbs closest to the machine's side panel.
11. If necessary, rotate the fuel tank barbs to point toward the machine's side panel.
12. Reconnect the fuel lines to the respective barb fittings and ensure they are fully seated.
13. Slide the hose clamps back onto the barb connections using a pair of pliers.
14. Reposition the straps through the grooves over the fuel tank.
15. Thread the bolt [A] through a washer [B], the fuel tank strap [C], washer [B], the machine side panel [E], and secure it with a hex nut [D].

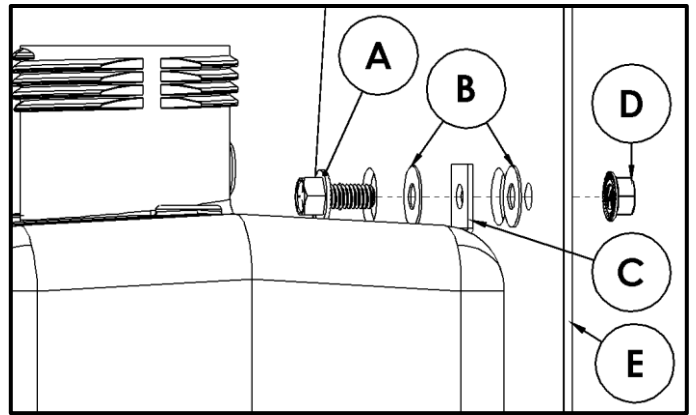

Figure 17 Hardware for Fuel Tank Strap

16. Torque the bolts to 30ft.lbs. (41N.m.)
17. Reinstall the fuel cap.
18. Reconnect the battery. [*Disconnecting and Connecting the Battery*]

## Nozzle Rotation V-Belt

### Tools & Supplies

- 9/16" Wrench

### Directions:

1. Apply the parking brake and remove the key from the ignition.
2. Remove the nozzle from the machine. [*Removing and Installing the Nozzle, Operator's Manual*]
3. Loosen but do not remove the bolts [A] holding the rotation motor bracket using a 9/16" wrench.

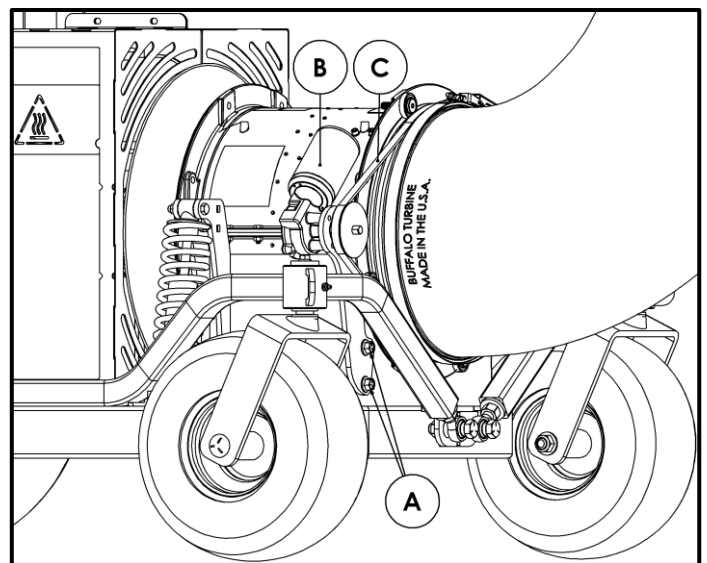

Figure 18 Nozzle Rotation V-Belt Removal

4. Pivot the rotation motor [B] with the bracket towards the blower to release tension on the V-Belt.
5. Remove the existing V-Belt [C] from the rotation motor pulley and base ring.

6. Attach the new V-Belt to the rotation motor pulley and base ring.
7. Pivot the rotation motor with the bracket away from the blower to tension the V-Belt.
8. Tighten the bolts from Step 3.
9. Torque to 35 ft-lbs (47.5 N·m).
10. Reinstall the nozzle on the machine. [*Removing and Installing the Nozzle, Operator's Manual*]

## Base Ring or Base Ring Bearings

### Tools & Supplies:

- 7/32" Hex Bit Socket
- 9/16" Wrench
- Ratchet
- Torque Wrench
- 9/16" Socket
- 

### Directions:

1. Apply the parking brake and remove the key from the ignition.
2. Remove the nozzle from the machine. [*Removing and Installing the Nozzle, Operator's Manual*]
3. Loosen but do not remove the bolts [A] holding the rotation motor bracket using a 9/16" wrench.
4. Pivot the rotation motor [B] with the bracket towards the blower to release tension on the V-Belt.
5. Remove the existing V-Belt [C] from the rotation motor pulley and base ring.

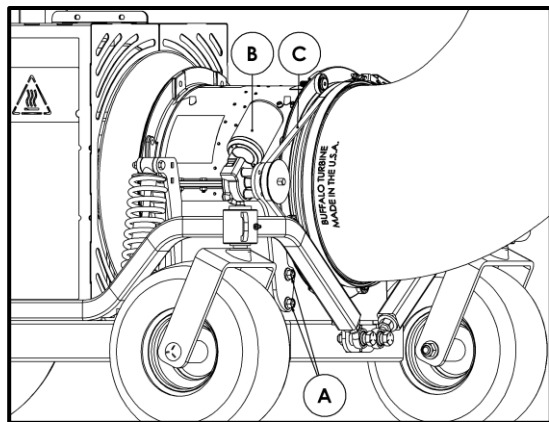

Figure 20 Nozzle Rotation V-Belt Removal

**Note:** If replacing multiple base ring bearings [G], avoid removing more than one at a time, as this may affect blower alignment. If replacing the base ring [E], only one bearing needs to be temporarily removed.

6. Remove the existing bearing using a 7/32" hex bit socket, ratchet and 9/16" wrench.
  - a. Remove the existing base ring.
  - b. Insert the new base ring.

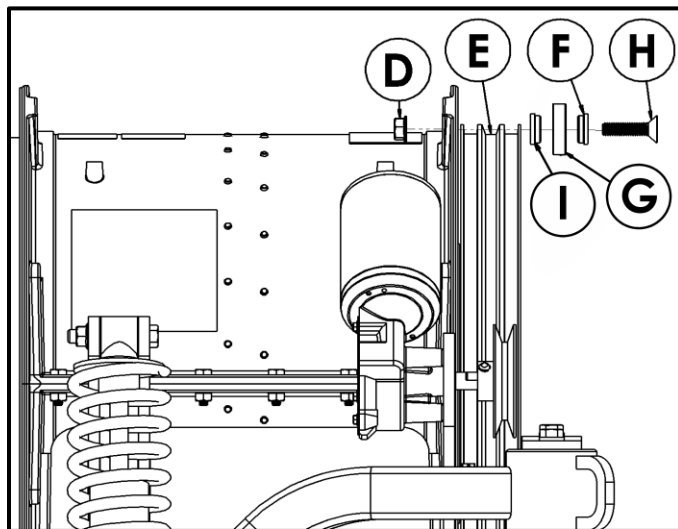

Figure 19 Base Ring Bearing Hardware

7. Tighten the new bearing into the original location. **Ensure** the spacers remain in the correct order, with [I] the larger spacer than [F].
8. Torque the bearings to 30ft-lbs (40.7 N·m).
9. Attach the V-Belt to the rotation motor pulley and base ring.
10. Pivot the rotation motor with the bracket away from the blower to tension the V-Belt.
11. Tighten the bolts from Step 3.
12. Torque to 35 ft-lbs (47.5 N·m).
13. Reinstall the nozzle on the machine. [*Removing and Installing the Nozzle, Operator's Manual*]

## Yoke or Front Wheel

### Tools & Supplies:

- 15/16" Socket
- 9/16" Socket
- Torque Wrench
- Ratchet

### Directions:

1. Apply the parking brake and remove the key from the ignition.
2. Loosen but do not remove the bolt [A] securing the front wheel assembly [D] to the machine using a 9/16" wrench.

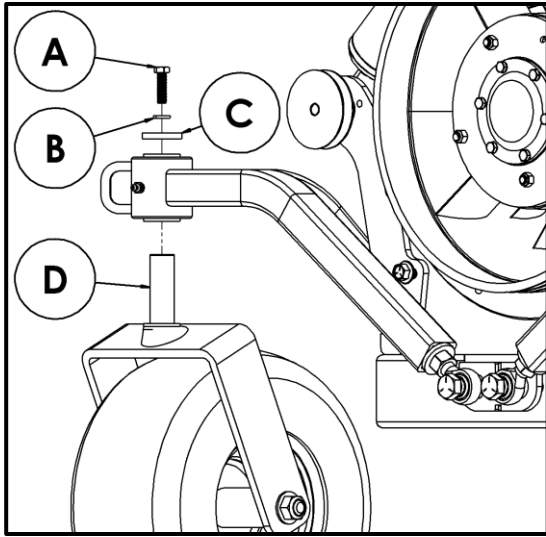

3. Lift the front end of the machine high enough to remove the front wheel assembly. [*Lifting and Hoisting, Operator's Manual*]

**Note:** Never work under a jack or hoist. Always support heavy objects that have been raised with appropriate jack stands or other suitable equipment rated for the weight of the object being lifted.

4. Remove the bolt from Step 2.
5. Slide the front wheel assembly off of the machine.
6. Remove the carriage bolt using a 15/16" socket and ratchet. **Note:** Direction of carriage bolt in relation to the yoke [F] and wheel valve stem.
7. Remove the wheel [I] and wheel spacers [H] from the front wheel assembly. [*Figure 21 Front Wheel Assembly Connection to Machine*]
8. Remove the wheel/yoke in need of replacement.
9. Replace the wheel/yoke.
10. Reassemble the front wheel assembly with the new wheel/yoke.

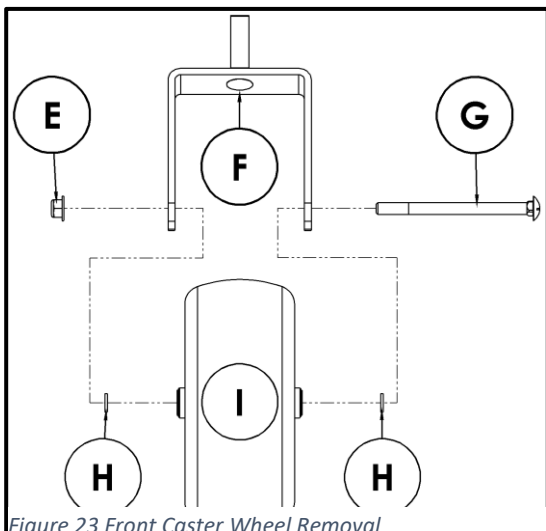

Figure 23 Front Caster Wheel Removal

11. Tighten the yoke around the wheel.
12. Torque to 98 ft-lbs (132.9 N·m).
13. Tighten the front wheel assembly to the machine by hand with the hardware shown.
14. Lower the machine back to the ground.
15. Torque to 30 ft-lbs (40.7 N·m).
16. Adjust the tire pressure as specified. [*Machine Specifications, Operator's Manual*]

## Front Shock/Spring

### Tools & Supplies:

- 9/16" Wrench
- 9/16" Socket
- Torque Wrench
- Ratchet

### Directions:

1. Apply the parking brake and remove the key from the ignition.
2. Lift the front end of the machine until the front wheels are just contacting the floor, using either method shown in the guide. [*Lifting and Hoisting, Operator's Manual*]

**Note:** Never work under a jack or hoist. Always support heavy objects that have been raised with appropriate jack stands or other suitable equipment rated for the weight of the object being lifted.

3. Remove the hex nut [A] at the top of the shock/spring [C] using a 9/16" wrench, 9/16" socket and ratchet.

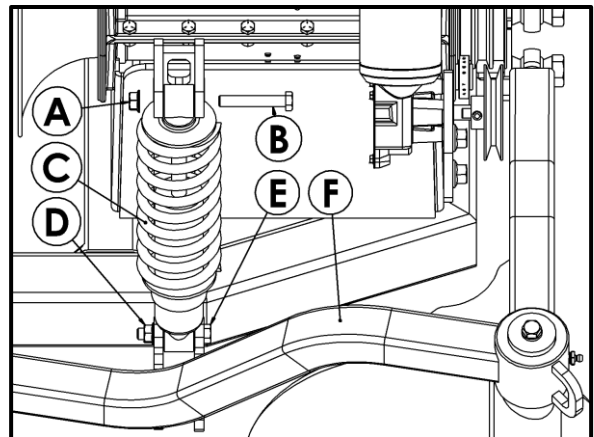

4. Remove the bolt [B] at the top of the shock/spring.

Figure 22 Front Shock/Spring Assembly Removal

- Note:** Might need to raise and lower the suspension arm [F] to release the bolt.
5. Remove the bolt [E] at the bottom of the shock/spring using the same tools from Step 3.
  6. Remove the existing shock/spring.

- Tighten the bolt at the bottom of the new shock/spring by hand to secure it to the suspension arm.
- Align the top of the shock to the upper shock/spring mount.
- Tighten the bolt at the top of the new shock/spring by hand to fully secure the shock/spring.
- Torque both bolts to 20 ft-lbs (27.1 N·m).
- Lower the machine back to the ground.

## Rear Shock/Spring

### Tools & Supplies:

- 9/16" Wrench
- 9/16" Socket
- Torque Wrench
- Ratchet

### Directions:

- Remove the key from the ignition.
- Remove the leaning pad from the machine and set it aside.
- Lift the front end of the machine until the front wheels are just contacting the floor, using either method shown in the guide. [*Lifting and Hoisting, Operator's Manual*]

**Note:** Never work under a jack or hoist. Always support heavy objects that have been raised with appropriate jack stands or other suitable equipment rated for the weight of the object being lifted.

- Remove the retaining clip [G] from the pin [F] securing the arm to the operator's platform to allow the shock/spring [A] to relax.

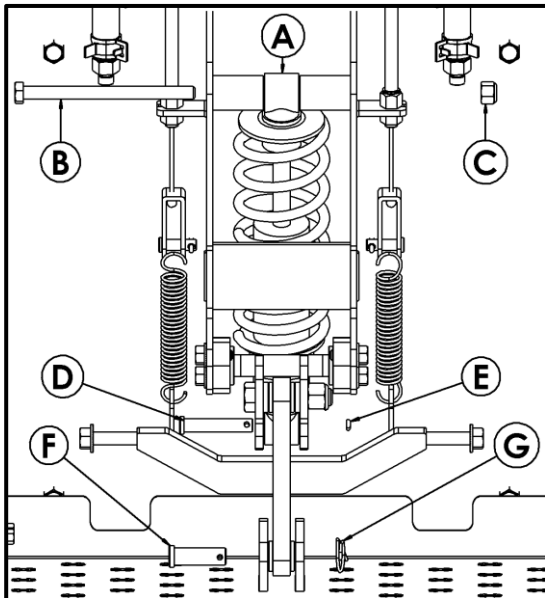

Figure 24 Rear Shock/Spring Assembly Removal

- Remove the retaining clip [E] from the pin [D] at the lower end of the shock/spring.
- Remove the bolt [B] from the upper end of the shock using a 9/16" wrench, 9/16" socket and ratchet.
- Pull the existing shock/spring out of the top of the housing it was mounted to.
- Insert the new shock/spring reverse of the removal process.
- Tighten the bolt [B] to secure the shock/spring to the housing.
- Insert the pin to connect the lower end of the shock/spring to the housing.
- Secure the pin with the retaining clip.
- Align the arm from Step 4 to the hole on the operator's platform.
- Insert the pin into the arm to connect the arm to the operator's platform .
- Secure the pin with the retaining clip.
- Torque the bolt [B] to 20 ft-lbs (27.1 N·m).
- Lower the machine back to the ground.
- Reattach the leaning pad.

## Reversing Contactor

### Tools & Supplies:

- 1/2" Socket
- 7/16" Wrench
- 3/8" Socket
- Torque Wrench
- Ratchet
- Optional**
- Marker
- Masking Tape

### Directions:

- Disconnect the battery. [*Battery Disconnect Procedure*]
- Optional:** Take a photo [Figure 25] of the contactor and connected wires for reference.



Figure 25 Contactor on Battery Tray

3. Remove the hex nut and lock washer from the studs securing the wires with a 1/2" socket and ratchet.
4. Remove one wire at a time, applying a piece of tape with text written on it according to the map [Figure 26], until all the wires have been removed.

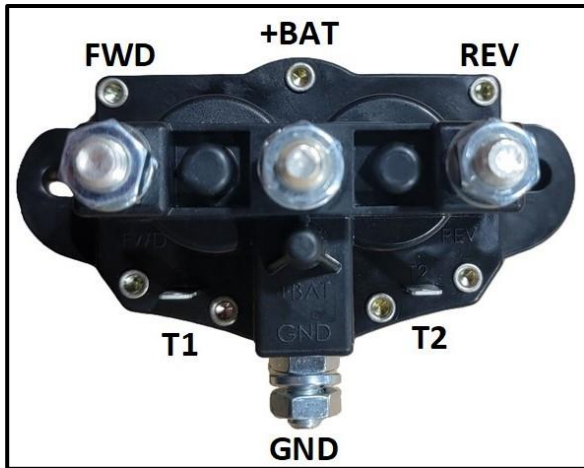

Figure 26 Labeled Contactor

5. Remove the existing contactor from the battery tray using a 3/8" socket and 7/16" wrench.
6. Place the new contactor, in the same orientation, into the previous contactor's location.
7. Thread the hardware to secure the contactor.
8. Torque bolts to 130in.lbs. (14.7N.m.)
9. Reconnect the wires to the contactor as they were prior to removal, according to the map [Figure 26].
10. Place the lock washer and hex nut back onto the stud and secure the ring terminals.
11. Torque the hex nuts to 120in.lbs. (13.6N.m.)
12. Reconnect the battery. [*Battery Disconnect Procedure*]
13. Test nozzle rotation functionality.

# 26HP Engine Replacement

## Tools & Supplies

- Torque Wrench
- MAP-Pro/Propane Torch
- 7/32" Hex Bit Socket
- (2) 9/16" Wrenches
- Marker
- 1/2" Breaker Bar
- Red Loctite 271
- 13/16" Socket
- 11/16" Socket
- Sandpaper
- 5/8" Wrench
- 3/8" Wrench
- 9/16" Socket
- P-Bit
- Rag
- 7/16" Socket
- 3-Jaw Puller
- Ratchet
- W-Bit
- Acetone

## Directions:

18. Chock the front wheels and remove the key from the ignition.
19. Disconnect the battery. [*Disconnecting and Connecting the Battery, Operator's Manual*]
20. Remove the 2 bolts fastening the shaft guard halves together using a 3/8" wrench, 7/16" socket and ratchet.
21. Remove the 2 bolts securing each half of the shaft guard to the frame using a 7/16" socket and ratchet.
22. Remove the shaft guard halves from the machine.
23. **CAUTION Exhaust can be hot.** Unbolt the center coupling [A] from between the engine and blower using a 5/8" wrench, 11/16" socket and ratchet.

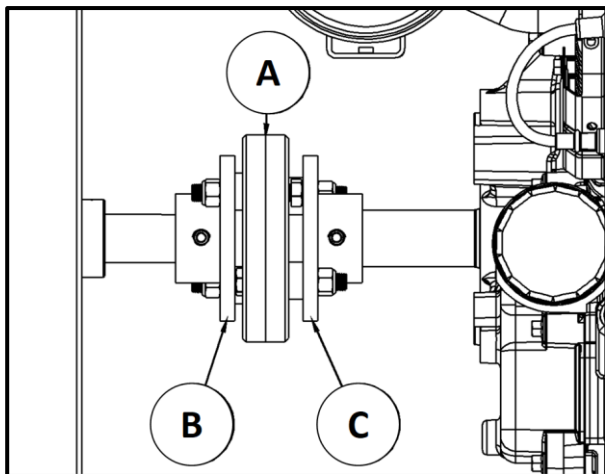

Figure 28 Shaft Coupling Assembly

24. Remove the 2 set screws from the blower shaft coupling flange [B] using a 7/32" socket hex bit and ratchet. **CAUTION** May require a MAP-Pro/Propane torch to heat the coupling flange where the set screws are as they were installed with red Loctite 271.
25. Repeat Step 24 for the engine shaft coupling flange [C].
26. Slide the engine coupling flange towards the engine. **Note:** The flange/engine will not be reused; use any

necessary method to move it without affecting the blower.

27. Remove the center coupling.
28. Remove the left upper parking brake spring from the top of the left parking brake cable.
29. Locate the parking brake cable brackets that are bolted to the battery tray.
30. Use a marker to mark the location of the bolt head in the left cable bracket, as shown [Figure 27].



Figure 27 Parking Brake Cable Bracket Location Marked

31. Remove the bolt and nut holding the left cable bracket to the battery tray using a pair of 9/16" wrenches, and set it aside.
  32. Break loose all 4 lug nuts on each rear wheel using a 13/16" socket on a 1/2" drive breaker bar.
  33. Lift the rear end of the machine through either of the methods shown in the guide. [*Lifting and Hoisting, Operator's Manual*]
- Note:** Never work under a jack or hoist. Always support heavy objects that have been raised with appropriate jack stands or other suitable equipment rated for the weight of the object being lifted.
34. Remove the lug nuts from each wheel using a 13/16" socket and ratcheting wrench.

35. Remove both wheels and set them aside.
36. Remove the 8 bolts holding the 2 access panels in place (located inboard of each rear wheel) using a 9/16" socket and ratchet.
37. Set the access panels and fasteners aside.
38. Insert the square drive of the 1/2" drive breaker bar into the square opening of the tensioner arm, as shown in [Figure 30].

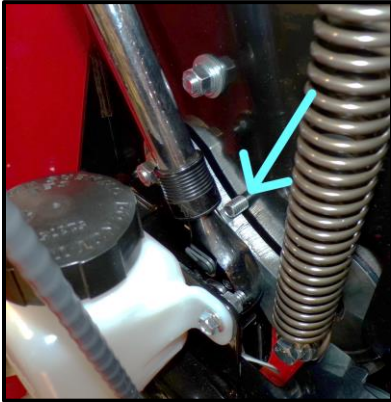

Figure 30 Breaker Bar on Tensioner Arm

39. Look through the left side access panel to locate a 3/8" diameter hole in the black pulley plate, just below the tensioner arm.
40. Relieve tension on the drive belt using the 1/2" drive wrench.
41. Hold the tensioner arm in the relief position.
42. Fully insert one of the bolts removed in Step 36 into the pulley plate as seen in [Figure 30].
43. Reduce the force applied to the breaker bar until the tensioner arm rests against the bolt.
44. Verify that the belt is relieved of all tension by reaching through the access panel and confirming that the belt is slack.
45. Remove the belt from the pulley on the engine shaft.
46. Remove the bolts securing the front panel using a 9/16" socket and ratchet.
47. Remove the front panel.
48. Remove the 2 ground cables connected to the engine block below the starter.
49. Disconnect the long fuel line from the connection shown by the blue arrow from the adapted fuel line connected to the tee shown by the green arrow near the oil filter as in [Figure 29]. **Ensure** to have a rag ready to collect any spilled fuel.
50. Cut 2 cable ties securing the fuel filter to the side panel.
51. Disconnect fuel line from the top of the fuel filter.

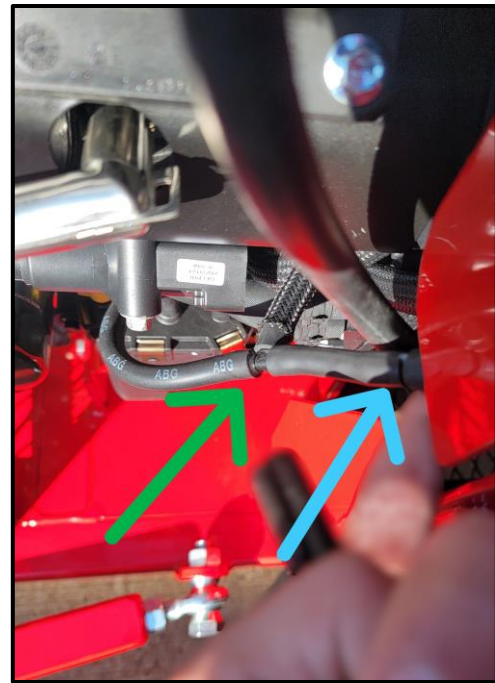

Figure 29 Fuel Line Tee on Engine

52. Disconnect the 8 pin connector in the area by the blue arrow besides the oil drain hose shown by the black arrow in [Figure 31].

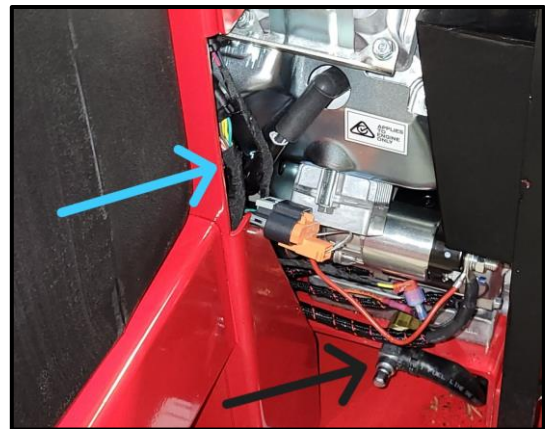

Figure 31 Main Harness Plugs Near Oil Drain Hose

53. Disconnect the ignition switch harness from the plug closest to the engine on the transaxle side of the engine.
54. Disconnect the 3 ring terminals connected to the starter.
55. Disconnect the right angle spade terminal connection beside the starter and oil drain hose.
56. Disconnect the straight spade terminal connected to the starter.
57. Untie and unwrap the hour meter wire from around the spark plug wire on the engine.
58. Disconnect the O2 sensor cable connector from the engine.

59. Remove the exhaust and exhaust port gaskets using a 9/16" wrench.
60. Remove bolts securing the engine to the engine mount using a 9/16" wrench, 9/16" socket and ratchet. **Note:** Direction of hardware to mount the engine to the engine mount.
61. Remove the engine via the 2 pick-up points near the valve covers of the engine.
62. Use a 3 jaw puller [D, Figure 32] to remove the blower shaft coupling flange and keystone. **CAUTION** May require a MAP-Pro/Propane torch to heat the coupling flange.
72. Remove oils and Loctite 271 residue from the shafts using a rag and acetone.
73. Check the alignment of the shafts at 4 locations, spaced 90° apart, using the provided alignment gauge.
  - a. Proper alignment is indicated by minimal or no gap between the alignment gauge and the shafts at any point.

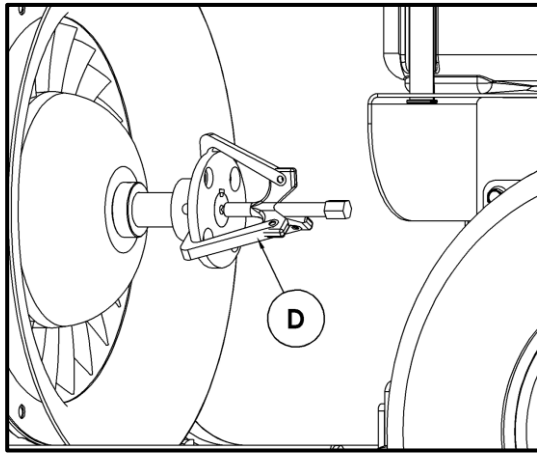

Figure 32 3-Jaw Puller on Turbine Coupling Flange

63. Remove the 2 set screws from the transaxle pulley using a 7/32" hex bit socket and ratchet. **CAUTION** May require a MAP-Pro/Propane torch to heat the setscrews.
64. Remove the stub shaft pulley from the old engine in a similar fashion as Step 62.
65. Place the stub shaft pulley onto the new engine for the V-Belt in the same orientation as the previous engine.
66. *\*If replacing Hour Meter\** Remove hour meter from the top panel and reinstall new one. **Note:** Consider recording hours to account for total machine hours.
67. Place the new engine on to the engine mount plate.
68. Rotate the engine on the engine mount as needed to connect the 8 pin plug and the ignition switch plug.
69. Rotate the engine back into final position over top of the mounting though holes.
70. Thread hardware to mount the engine to the engine mount plate by hand with the same hardware direction as Step 59.
71. Remove burrs from the blower and engine shafts using sandpaper.

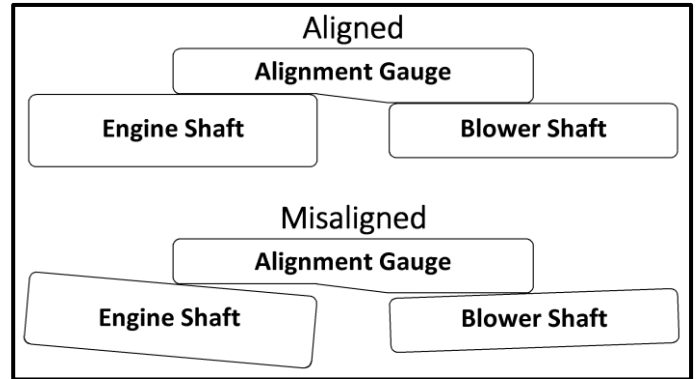

Figure 33 Alignment Gauge

74. Adjust the alignment of the engine by shifting the engine laterally until proper alignment is achieved.
75. Tighten the engine to the engine mount when shafts are aligned.
76. Torque to 38 ft-lbs (51.5 N·m).
77. Place the keystone into the slot on the engine shaft.
78. Slide the new coupling flange on to the engine shaft.
79. Place the keystone into the slot on the blower shaft.
80. Slide the coupling flange from Step 62 on to the blower shaft.
81. Insert and align the coupling center between the coupling flanges.
82. Bring the flanges up to the coupling center.
83. Insert the hardware through the coupling center and flanges as it was in Step 23.
84. Torque to 50 ft-lbs (67.8 N·m).
85. Place 6 drops of red Loctite 271 into the set screw holes that lead to the keystone on both coupling flanges.
86. Thread a setscrew with 3 drops of red Loctite 271 on the threads into each of the holes from Step 85.
87. Torque to 35 ft-lbs (47.5 N·m).
88. Drill a dimple on the engine shaft through the opposite set screw hole on the coupling flange using a W bit.
89. Repeat Step 88 for the blower shaft if there is no dimple aligned with the set screw hole.

90. Repeat Steps 85–87 for the remaining set screw holes on the coupling flanges.
91. Reconnect the long fuel line to the adapted fuel line connected to the tee near the oil filter.
92. Secure the fuel filter to the side panel with two cable ties.
93. Reconnect the fuel line to the top of the fuel filter.
94. Reconnect the 8-pin plug nearby the .
95. Reconnect the 3 ring terminals to the starter from the main machine harness.
96. Reconnect the right-angle spade terminal.
97. Reconnect the straight spade terminal to the starter.
98. Reconnect the 2 ground cables to the engine block below the starter.
99. Wrap and tie the hour meter wire around the spark plug wire as previously installed.
100. Start all bolts on the front panel by hand.
101. Torque to 35 ft-lbs (47.5 N·m).
102. Remove the lower access panel using a 9/16" socket and ratchet.
103. Align the stub shaft pulley to the transaxle pulley using a flat edge along the inboard face of the pulley, ensuring a 1/16" gap between the pulley and transaxle pulley.

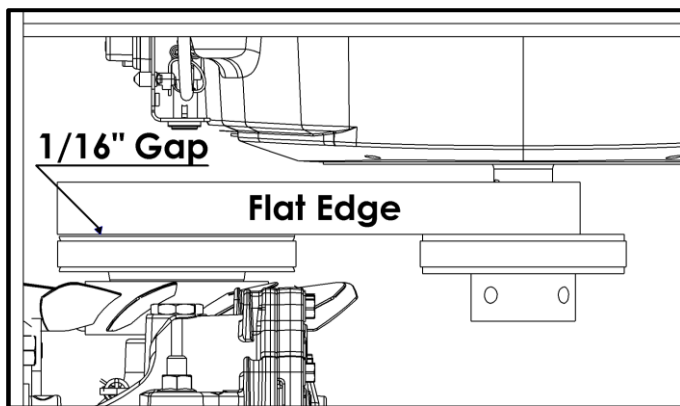

Figure 34 Engine Pulley Alignment to Transaxle Pulley

104. Place 6 drops of red Loctite 271 into the set screw holes that leads to the keystone.
105. Thread a set screw with 3 drops of red Loctite 271 on the threads
106. Torque to 30 ft-lbs (40.7 N·m).
107. Drill a dimple on the engine shaft through the opposite set screw hole on the pulley using a P bit.
108. Repeat Steps 104–106 for the remaining set screw hole on the engine shaft pulley.

109. Slip the V-Belt back onto the engine pulley. **Ensure** that it matches [Figure 35].

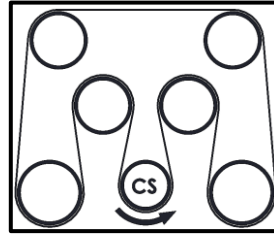

Figure 35 Drive Belt Routing

110. Release tension off of the bolt from Step 42.
111. Remove the bolt.
112. Check all 7 pulleys to ensure the belt is properly engaged and centered on each one.
113. Start all bolts on the 3 access panels by hand.
114. Torque to 35 ft-lbs (47.5 N·m).
115. Place the rear wheels onto the rear hubs.
116. Start the lug nuts by hand.
117. Lift the rear end of the machine through either of the methods shown in the guide. [*Lifting and Hoisting the Machine, Operator's Manual*]
118. Remove the jack stands.
119. Lower the machine down onto the ground.
120. Torque lug nuts to 90 ft-lbs (122 N·m).
121. Reinstall parking brake bracket from Step 31.
122. Tighten the bracket to the marked location from Step 30.
123. Torque to 35 ft-lbs (47.5 N·m).
124. Reinstall the left upper parking brake spring to the upper loop of the left parking brake cable.
125. Engage and disengage the parking brake to ensure it is functioning properly. **Note:** Adjust the parking brake if necessary. [*Adjusting/Testing the Parking Brake, Operator's Manual*]
126. Reinstall the exhaust and exhaust port gaskets.
127. Connect the O2 sensor to the engine.
128. Torque to 20 ft-lbs (27.1 N·m).
129. Reinstall the shaft guard halves to the frame.
130. Tighten the top flanged connection between the 2 guard halves.
131. Torque all guard bolts to 8 ft-lbs (10.8 N·m).
132. Verify that the guard is securely installed and that the wire is properly clamped in place.
133. Reconnect the battery. [*Disconnecting and Connecting the Battery, Operator's Manual*]