



BLITZ BT-SB40

Stand-On Debris Blower

Operator's Manual



Contents:

Introduction and Safety:

Introduction and Product Identification	1
Operational Safety and Guidelines	2
Slope Guide	7

Warranty:

Buffalo Turbine Warranty Policy	8
Warranty Registration Form	9

Controls and Adjustment:

Control Functions and Location	10
Adjusting the Operator's Platform.....	11
Removing the Leaning Pad.....	11
Adjusting/Testing the Parking Brake.....	12
Adjusting the Motion Control Arms.....	13

Maintenance Overview:

Machine Specifications	14
Maintenance Schedule	15
Maintenance Log.....	16
Engine Maintenance	17
Transaxle Maintenance.....	17
Battery Maintenance	17
Lifting and Hoisting the Machine	18

Component Identification:

Engine Component Identification	20
Transaxle Component Identification.....	20
Fuse Box Location & In-Line Fuse Identification	21
Fuse Box Component Identification.....	21

Pre-Operation Inspection:

Checking/Adding Fuel	22
Checking Tire Pressure.....	22
Checking Engine Oil Level	22
Checking/Adding Transaxles' Oil.....	23

Maintenance Procedures:

Greasing the Machine	23
Changing the Engine Oil and Filter.....	23
Changing the Air Filter	24

Changing the Fuel Filter	25
Changing the Transaxles' Oil and Filters	26
Air Purging the Transaxles	27
Disconnecting and Connecting the Battery	28
Removing and Installing the Battery.....	29
Changing the Drive Belt	30
Removing and Installing the Guard.....	31
Removing and Installing the Nozzle.....	32

Cleaning the Machine:

Cleaning with Pressurized Air and Water	32
Cleaning the Blower.....	32

References:

Wiring Diagram	33
Parts References	35
Quick Reference QR Codes	45
Bill of Materials	46

Troubleshooting:

Troubleshooting Guide	51
-----------------------------	----

Introduction and Product Identification

Congratulations on selecting the Buffalo Turbine Debris Blower. This equipment is engineered and manufactured to meet the specific requirements of the turf care industry.

To ensure safe, efficient, and reliable operation, it is imperative that you, as well as any personnel involved in the operation or maintenance of the Debris Blower, thoroughly read and understand the safety, operation, maintenance, and troubleshooting instructions provided in this Operator's Manual.

This manual pertains to the **BLITZ BT-SB40 Stand-On Debris Blower**. Keep this manual accessible for regular reference and transfer it to any subsequent operators or owners. Should you require assistance or additional information, contact your Buffalo Turbine dealer or distributor.

Serial Number Location:

When ordering parts or requesting service or information, always provide your dealer with the serial number of your Debris Blower. The serial number plate [A] is centered on the control panel as shown in the images below. An example of what this tag looks like is shown.

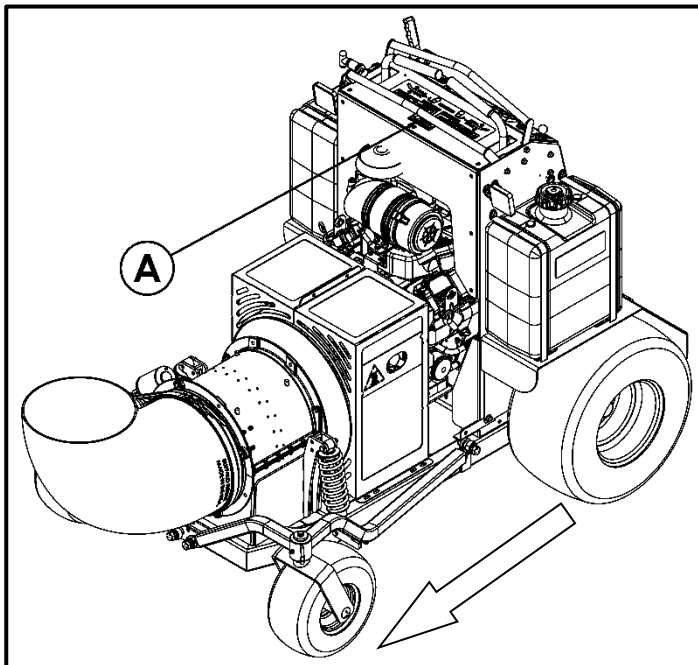

Operator Orientation:

The terms left, right, front, and rear, as used in this manual, refer to the orientation as viewed from the operator's standing platform, facing the direction of forward travel.

For your records, document your machine's model number, serial number, dealer contact, and purchase date in the space provided below.

Machine Information Record	
Model Number:	
Serial Number:	
Purchase Date:	
Dealer Contact:	

Operational Safety and Guidelines

Overview:

This operator's manual provides essential safety information and guidelines to ensure the safe operation and maintenance of your machine. It outlines key precautions, operating practices, and maintenance procedures designed to prevent accidents, injuries, and damage to property or equipment.

Operators are expected to familiarize themselves with all safety instructions and follow recommended practices at all times. This manual includes detailed safety practices specific to this machine.

For your safety and the safety of others, always adhere to the guidelines provided in this manual and comply with local regulations related to equipment use.

Understanding Safety Symbols and Terms

Attention! Your Safety is Involved!

The Safety Alert symbol is used to indicate important safety messages throughout this manual and on the machine itself. When you see this  symbol, pay immediate attention to the potential for personal injury or death. Follow all safety instructions closely.

Signal Words Used in This Manual:

 **DANGER** – Indicates an immediate hazard that, if not avoided, will result in serious injury or death.

 **WARNING** – Identifies a specific hazard or unsafe practice that could lead to severe injury or death if not followed correctly.

 **CAUTION** – Highlights unsafe practices that could result in minor injury or serves as a reminder for safe practices.

Note – Provides important information or instructions to clarify steps or provide additional context, similar to a notice.

Optional – Identifies steps, components, or actions that are not required to complete the task but may offer additional benefits.

Recommendation – Advises steps or actions to prevent avoidable or inconvenient issues, enhancing safety or operational efficiency.

Why Safety Matters

- Accidents can cause serious injury or death.

- Accidents are costly and disrupt operations.
- Accidents can be prevented by following proper safety procedures.

California Proposition 65



WARNING This product can expose you to chemicals which are known to the State of California to cause cancer and birth defects or other reproductive harm. For more information, go to www.P65Warnings.ca.gov

Safety and Training

As the owner, **YOU** are responsible for the safe operation and maintenance of your Buffalo Turbine Debris Blower. Ensure that everyone who operates, maintains, or works around this equipment is fully familiar with the procedures and safety information provided in this manual. This guide will help you incorporate essential safety practices into your daily routine.

Safety Starts with You

Implementing safe practices not only protects you but also protects those around you. Make safety a standard part of your operations, and ensure everyone using the machine understands and follows the necessary precautions. Most accidents are preventable—never ignore safety practices.

- Ensure all operators and mechanics read the operator's manual and other training materials thoroughly. If they cannot read English, the owner must explain the material to them.
- Provide proper training to all operators and mechanics before they use or service the machine. Conduct training in an open, clear area under the supervision of an experienced operator, and provide refresher training annually.
- Ensure all users understand the machine's controls, safety signs, operating procedures, emergency protocols, and the correct use of accessories.
- Allow only trained individuals to operate the machine. Do not permit children or untrained individuals to use or service the equipment. Follow local age restrictions and regulations.
- Never modify the machine or any of its components. Unauthorized modifications can compromise safety and reduce the equipment's functionality and lifespan.
- The owner or user is responsible for preventing accidents or injuries to themselves, others, and property. Inspect the work area for hazards and ensure

the equipment is in proper working condition before each use.

Think Safely! Work Safely! By incorporating these practices, you contribute to a safer working environment and reduce the risk of accidents or injuries.

Before You Begin

Assess the job site to determine the appropriate actions needed for safe and efficient operation. Use only manufacturer-approved accessories and attachments.

Examine the area where the machine will be used and remove all objects, such as rocks, toys, and debris, that could be thrown by the equipment during operation. Ensure the area is clear of people and pets.

Personal Protective Equipment (PPE)

Operators must wear a hard hat, safety glasses, hearing protection, and slip-resistant footwear. Secure long hair, and avoid wearing loose clothing or jewelry that could become entangled in moving parts.

Perform Pre-Operation Checks

- Ensure the battery is properly connected before operation as it is disconnected for shipping.
- Check fuel, oil, and other engine specifications according to the manufacturer's guidelines.
- Verify that guards are securely in place and functioning as designed.
- Inspect all belts and pulleys for proper tension and alignment.

Check for Debris Accumulation

Ensure that no leaves, grass, or debris have accumulated on or near the engine or exhaust system, as this could pose a fire hazard.

Following these steps will help minimize risks and ensure the Buffalo Turbine Debris Blower is prepared for safe operation.

Operating Safely

- Inspect the machine before each use. Tighten any loose hardware, replace damaged or missing parts, and ensure all guards are in good condition. Make necessary adjustments before starting.
- Always inspect the blower, bolts, and connections to the blower for wear or damage.
- Never run the engine in an enclosed area to avoid carbon monoxide buildup.

- Operate only in well-lit areas, steering clear of holes and hidden hazards.
- **DO NOT** operate the machine under the influence of alcohol or drugs.
- **DO NOT** wear headphones or listen to music while operating the unit.
- Ensure motion control arms are in the neutral position before starting the engine.
- Keep hands, feet, and other body parts away from the intake and discharge area.
- **DO NOT** aim blower discharge at people or animals.
- Stop and inspect the machine if unusual vibrations occur.
- Stop the machine on level ground, engage the parking brake, and shut off the engine before leaving the operator's platform.
- Drive backward when ascending slopes and forward when descending to maintain control and stability.
- Slow down when making turns, crossing roads, or approaching blind corners.
- Look behind and down before backing up to ensure a clear path.
- Never allow passengers on the machine and keep pets and bystanders away.
- Load the machine onto trailers or trucks in reverse for safer handling.
- Remove the key when the machine is unattended, stored, or parked to prevent unauthorized use.
- **DO NOT** tow attachments, equipment, or loads with this machine under any circumstances.

Work Area Preparation

Before using the machine, carefully evaluate the terrain to identify the appropriate tools and attachments required for safe operation. Plan the operation to avoid areas with unstable or slippery surfaces. Perform a test run to check the machine's stability and handling, especially on uneven ground:

- Remove all objects that could be hazardous.
- Confirm that the area is clear of people and animals. Use only tools and attachments approved by the manufacturer. Avoid operating in areas where stability or traction is uncertain.

Child Safety Precautions

- Children are attracted to equipment but may not understand the dangers. Always assume they could be nearby.

- Never give children rides on the equipment or tow them in carts or trailers.
- **DO NOT** allow children or untrained people to operate the equipment.
- Keep children out of the work area and supervised by an adult who is not the operator.
- Stay alert for children, especially when backing up. Turn off the machine immediately if a child enters the area.

No Riders Allowed

- Never allow passengers on the machine. Extra riders can fall, interfere with safe operation, or cause a loss of control.

Parking the Machine

1. Stop the machine on level ground and ensure the motion control arms return to the neutral position.
2. Turn off the machine, engage the parking brake, and remove the key from the ignition.
3. Confirm all moving parts have stopped before stepping off the operator's platform.

Prevent Fires

Gasoline is highly flammable and should be handled with extreme caution to prevent personal injury or property damage:

- Allow the engine to cool for at least 3 minutes before refueling. Never refuel the machine while the engine is running.
- **DO NOT** permit open flames, smoking, or matches in the vicinity while handling fuel.
- Avoid overfilling the fuel tank, and clean up any spills immediately. If fuel is spilled near the unit, do not start the engine until the spill is cleaned and vapors have dissipated.
- Use a clean, approved non-metallic container to prevent static discharge. Never fill containers inside a vehicle or on a truck or trailer bed; always place containers on the ground away from the vehicle before adding fuel.
- Always use a clean, approved non-metallic funnel equipped with a plastic mesh strainer when refilling the fuel tank.
- Store fuel in an approved container away from any open flame, spark, or pilot light, such as those on water heaters or appliances.
- Avoid using gasoline with methanol; it is harmful to both health and the environment.

- Keep the fuel nozzle in contact with the rim of the fuel tank or container opening while fueling, and do not use a nozzle lock open device.

Spark Arrester Use

The engine is equipped with a spark arrester to meet safety regulations, including California Public Resource Code Section 4442 and Federal Regulation 36 CFR Part 261.52. This arrester must be maintained in good working order to prevent fire hazards when operating near forest-covered, brush-covered, or grass-covered areas.

Regularly inspect the spark arrester for any signs of damage, debris, or blockages. Clean the arrester as needed to ensure proper function, and replace it if any defects are found.

Before performing any maintenance on the exhaust system, turn off the engine and allow it to cool for at least two minutes to avoid burns. Clear away any combustible material around the muffler and engine to reduce the risk of fire.

Managing Spilled Fluids and Proper Disposal

When performing inspection, maintenance, testing, adjustment, or repair of the machine, ensure that all fluids are properly contained. Be prepared to collect fluids with suitable leakproof containers before opening or disassembling any component that contains fluids. In the event of a spill, immediately contain the spill using absorbent materials, and clean the area thoroughly to prevent slipping hazards or damage to the machine.

Never pour waste fluids onto the ground, down a drain, or into any source of water, as improper disposal can harm the environment. Collected waste, including used absorbent materials and contaminated fluids, should be placed in designated, clearly labeled containers and disposed of according to local regulations and mandates. Use a licensed waste disposal service to ensure proper handling of hazardous materials. Always wear appropriate personal protective equipment (PPE) when handling fluids and during the disposal process to protect yourself and maintain a safe work environment.

Tire and Wheel Safety

 **WARNING** Improper handling of tire and rim assemblies can result in serious injury or death.

- Always maintain the correct tire pressure and never exceed the recommended pressure in *Machine Specifications*.

- **DO NOT** mount a tire without proper equipment and experience.
- Never weld or heat a wheel and tire assembly; this can cause an explosion or weaken the wheel.
- When inflating tires, use a clip-on chuck and an extension hose that allows you to stand to the side, away from the front or top of the tire assembly.
- Regularly inspect rear wheel hardware and tighten to 90 ft-lbs (122 N·m) using the proper procedure, especially during the first 100 hours of operation.
- Release pressure from the transaxles by moving the control levers back and forth with the engine off.

Maintenance

- Engage the parking brake, stop the engine, and remove the key before adjusting, cleaning, or repairing. Wait for all movement to stop before proceeding.
- Clean all debris from the machine to prevent fire hazards and clean up any oil or fuel spills immediately.
- Use properly rated jack stands to securely support machine when performing maintenance.
- Release pressure from the transaxles by moving the control levers back and forth with the engine off.
- Keep hands, feet, clothing, jewelry, and long hair away from moving parts.
- Charge the battery in a well-ventilated area away from sparks or flames. Unplug the charger before connecting or disconnecting it from the battery. Wear protective clothing and use insulated tools.
- Regularly check and tighten all hardware, including blower attachment bolts, to ensure the equipment is in safe working condition. Replace worn or damaged components and decals as needed.
- Frequently check parking brake operation to ensure proper functionality.

Storing the Machine

- Store the machine away from areas of frequent use. Do not allow children to play on or around the stored machine.
- Ensure the machine is on a firm, level surface and securely blocked to prevent it from tipping or sinking into soft ground.
- Cover the machine with a weatherproof cover and secure it tightly to protect it from the elements.
- Allow the engine to cool before storing, and do not store near any open flames or heat sources.
- Never store fuel near open flames or heat sources.
- **DO NOT** drain fuel indoors; always drain in a well-ventilated outdoor area.

Blower Dangers

 **WARNING** Rotating blower blades can cause severe injury, including amputations, and can also eject debris at high speeds. Adhering to the following safety guidelines is crucial to prevent serious injury or death:

- Ensure that all bystanders, including children and pets, maintain a safe distance of at least 50 feet from the machine while it is operating.
- Keep hands, feet, and clothing away from the blower housing when the engine is running.
- Remain vigilant, maintain control and avoid distractions while operating, as people or children may enter the work area, increasing the risk of accidents with the blower.
- Inspect the blower only when the engine is off and all movement has completely stopped.

Prevent Tipping

Before operating on slopes, use the Slope Guide to ensure the grade of does not exceed 15°. Operating on slopes greater than 15° significantly increases the risk of loss of control, tip-over, and severe injury or death. Always evaluate the slope carefully and follow all safety precautions.

- **DO NOT** drive forward up slopes or backward down slopes; the machine's rear-heavy design increases the risk of tipping when operated outside the recommended.
- Use low speeds on slopes to maintain control and prevent sudden stops or traction loss.
- Keep movements slow and gradual, avoiding sudden changes in speed or direction.
- Avoid operating on wet grass as it decreases traction.
- Avoid turning while driving perpendicular to slopes; always exit the slope using the smoothest, most gradual path possible.
- Avoid obstacles like holes, rocks, bumps, drop-offs, ditches, and bodies of water, as these can cause instability or tipping; tall grass can conceal these hazards.
- Load the machine onto trailers or trucks in reverse for safer handling.

Stickers

Safety stickers and icons on the machine show essential warnings and instructions. Operators must know their locations and meanings, as these symbols highlight hazards and safe operating practices. Regularly check that decals are intact and legible.

⚠ WARNING Replace any that are missing or damaged to ensure continued safety.

Sticker Identification

- Operator Tower Decal: [A]
- Guard Requirement Decal: [B]
- Combined Warning Decal: [C]

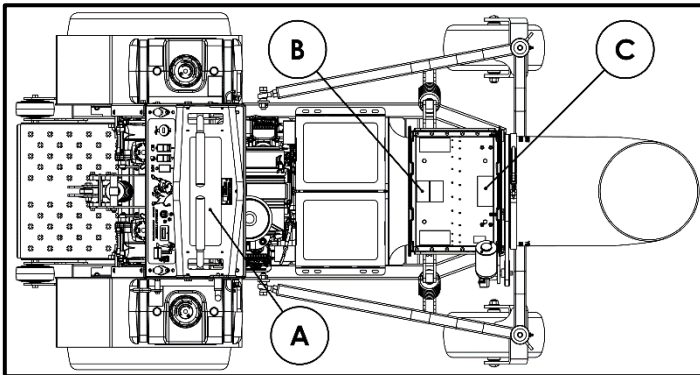

Operator Tower Decal, Part Number: 5041



Guard Requirement Decal, Part Number: 1186



Combined Warning Decal, Part Number: 4725



	Indicates important cautions or warnings that MUST be followed.
	Wear hearing protection to prevent hearing loss.
	Wear eye protection to prevent injury.
	WARNING Thrown objects can cause serious injury.
	DO NOT refuel with engine running or with hot engine.
	Read and understand the Owner's Manual before operation. Be sure you know all sections with an emphasis on safety and operation.
	Keep clear of all moving and hot parts. Keep all guards in place during operations.
	Keep unit clean and free of debris, especially around exhaust. Failure to do so can cause fire.
	Use extreme caution when operating on slopes. Always use slow deliberate movements avoiding high speed or sudden movements.

Slope Guide

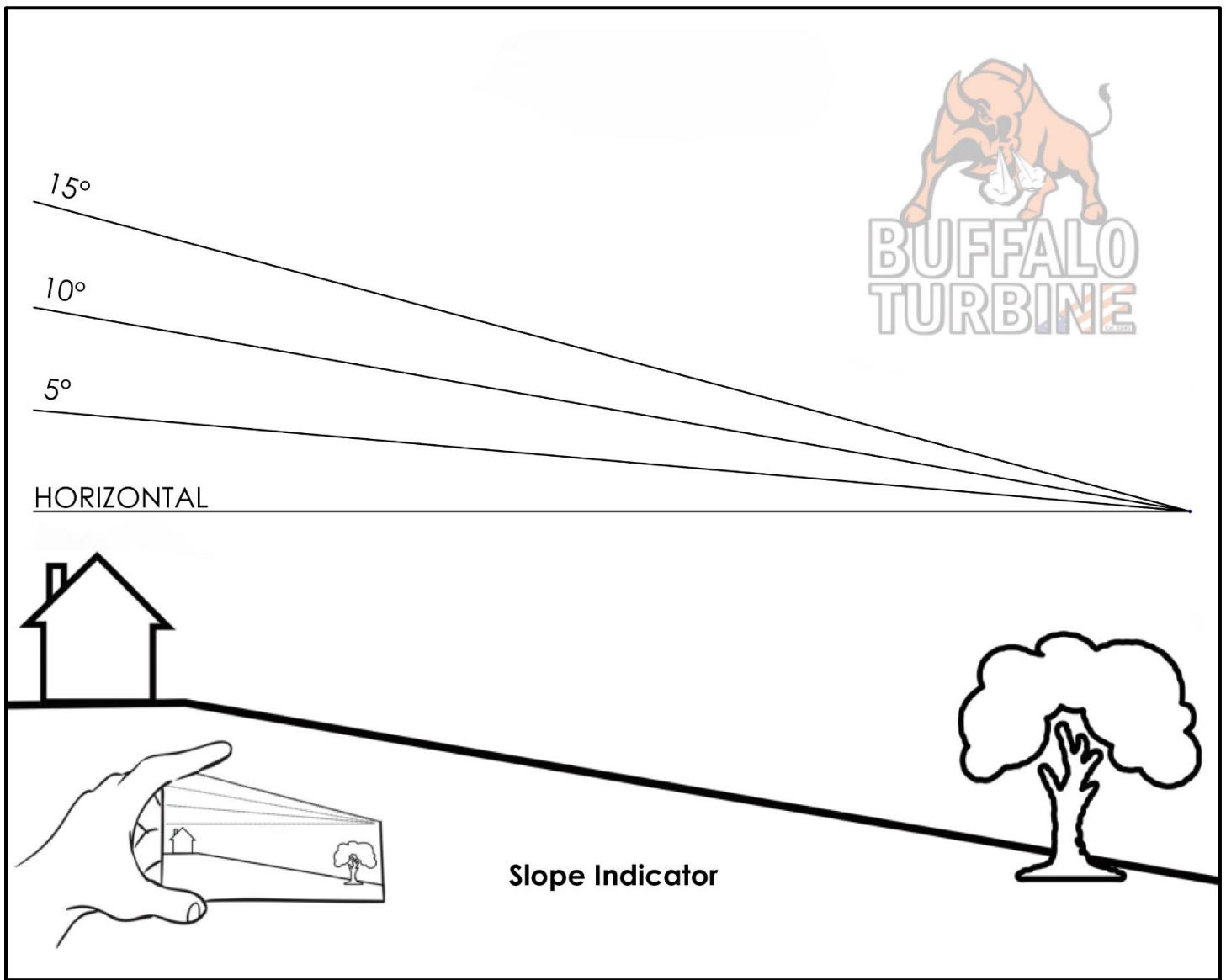

Use this guide to measure and confirm the slope for safe operation.

1. Fold the guide along the line that matches the recommended slope from your machine's manual.
2. Hold the guide at arm's length and align its right edge with a vertical surface, such as a tree or building.
3. Compare the folded edge of the guide to the slope of the terrain. If the slope exceeds the folded edge, it is too steep for safe operation.

Refer to *Operational Safety and Guidelines* for safe operating procedures

Buffalo Turbine Warranty Policy

MACHINE WARRANTY INFORMATION

Buffalo Turbine warrants the DEBRIS BLOWER, to the original owner, to be free from defects in material and workmanship, under normal use and service. All machines must have a completed registration form sent to Buffalo Turbine within 30 days of purchase for warranty to apply. Obligation under this warranty shall extend for a period of 10 years from date of purchase and, at the option of Buffalo Turbine, replacement of any parts found, upon inspection by Buffalo Turbine, to be defective. Any parts replaced under warranty will have the remainder of the warranty from the original date of purchase.

Warranty parts during first 2 years will be shipped free of charge via standard ground shipping

If expedited shipping is required charges will be paid by the end user

Year 1: Parts and Labor

Year 2: Parts Only

Customer will be required to pay shipping charges for years 3-10

Year 3: Engine, per engine manufacturer's standard / Turbine Assembly / Frame (parts only)

Year 4-10: Turbine Assembly / Frame (parts will be prorated)

Buffalo Turbine reserves the right to incorporate improvements in material and design of its products without notice and is not obligated to make the same improvements to equipment previously manufactured.

ALL WARRANTY REPAIRS NEED PRE-APPROVAL BY A FACTORY PERSON (FROM BUFFALO TURBINE) PRIOR TO COMMENCING WITH A WARRANTY REPAIR TO INCLUDE SERIAL NUMBER AND HOURS FROM HOUR METER (IF EQUIPPED). PRE-APPROVAL WILL BE REQUIRED BY THE END USER AND DEALER/DISTRIBUTOR LEVEL.

Factory ordered Buffalo Turbine parts must be used when filing a warranty claim.

LIMITATIONS OF LIABILITY

This warranty is expressly in lieu of all other warranties expressed or implied and all other obligations or liabilities on our part of any kind or character, including liabilities for alleged representations or negligence. We neither assume nor authorize any other person to assume on our behalf, any liability in connection with the subsequent sale of the DEBRIS BLOWER. This warranty shall not apply to any DEBRIS BLOWER, which has been altered outside the factory in any way so as, in the judgment of Buffalo Turbine, to affect its operation or reliability, or which has been subject to misuse, neglect, or accident.

This warranty does not cover parts and accessories, which are under separate guarantee from the manufacturers and service can be, obtained from their service facilities. No warranty is extended to regular service items such as lubricants, belts, paint and the like.

Original Instruction Manual

The Purchaser acknowledges having receiving training in the safe operation of the DEBRIS BLOWER and further acknowledges that Buffalo Turbine does not assume any liability resulting from the operation of the DEBRIS BLOWER in any manner other than described in the Operator's Manual supplied at the time of purchase.

WARRANTY VOID IF NOT REGISTERED (see Page 2 for warranty registration form)

DO NOT SPLIT THE TURBINE HOUSING FOR ANY REASON.

DO NOT ATTEMPT TO SERVICE OR DISASSEMBLE THE TURBINE BLOWER.

DO NOT USE THE TOP OF THE TURBINE HOUSING TO STRAP OR TIE DOWN BLOWER UNITS.

Unauthorized service work on the Turbine Blower will null and void all warranties.

If there are any questions regarding any of our products call Buffalo Turbine at 716 592 2700.

Warranty Registration Form

BUFFALO TURBINE

WARRANTY REGISTRATION FORM & INSPECTION REPORT

Any units not registered with Buffalo Turbine are not eligible for warranty claims.

This form must be filled out by the dealer and signed by both the dealer and the customer at the time of delivery.

Contact Information

Customer's Name	_____	Dealer's Name	_____
Address	_____	Address	_____
City, State, Zip, Country	_____	City, State, Zip, Country	_____
Email Address (Required)	_____	Email Address	_____
Phone Number	_____		

Equipment Details

Blower Model	_____	Circle One:
Serial Number	_____	Commercial Use
Delivery Date	_____	Private Use

Dealer Inspection Report

Safety Checks

Tire Pressure Check (Model KB)	_____	All Decals Installed	_____
Wheel Bolts	_____	Review Operating and Safety Instructions	_____
Belt Tension	_____	Guards in Place	_____
Lubricate Machine	_____	Trailer Assembly Bolts Properly Installed and Tightened	_____
Fasteners Tighten	_____		

ALL 3 POINT HITCH MODELS: PTO SHAFTS MUST TELESCOPE IN EVERY POSITION

Acknowledgment

I have thoroughly instructed the buyer on the above-described equipment, including the content of the Operator's Manual, equipment care, adjustments, safe operation, and applicable warranty policy.

Date _____ Dealer's Rep. Signature _____

The above equipment and Operator's Manual has been received by me and I have been thoroughly instructed as to the care, adjustments, safe operation and applicable warranty policy.

Date _____ Owner's Signature _____

Control Functions and Location

Motion Control: [Left Wheel A, Right Wheel B]

- Push both arms forward to drive forward
- Pull both arms backwards to drive backwards
- Push or Pull Individual arms to turn

Nozzle Rotation: [C, D]

- Rotate nozzle CCW [C]
- Rotate nozzle CW [D]

Battery Voltage Display and Auxiliary Port [E]

- USB 3.0 and Type C charging with battery voltage display

Headlight Switch [F]

- Flip switch forward to turn headlights on
- Flip switch backward to turn headlights off

Fuel Tank Selector Switch [G]

- Flip switch forward to select right tank
- Flip switch backward to select left tank

Accessory Switch Port [H]

- Precut port for additional accessories

Ignition Switch [I]

Hour Meter/Tachometer [J]

- Displays engine hours and engine RPM

Throttle Lever [K]

- Adjust the throttle as needed

Parking Brake [L]

- Pull handle backwards to engage parking brake

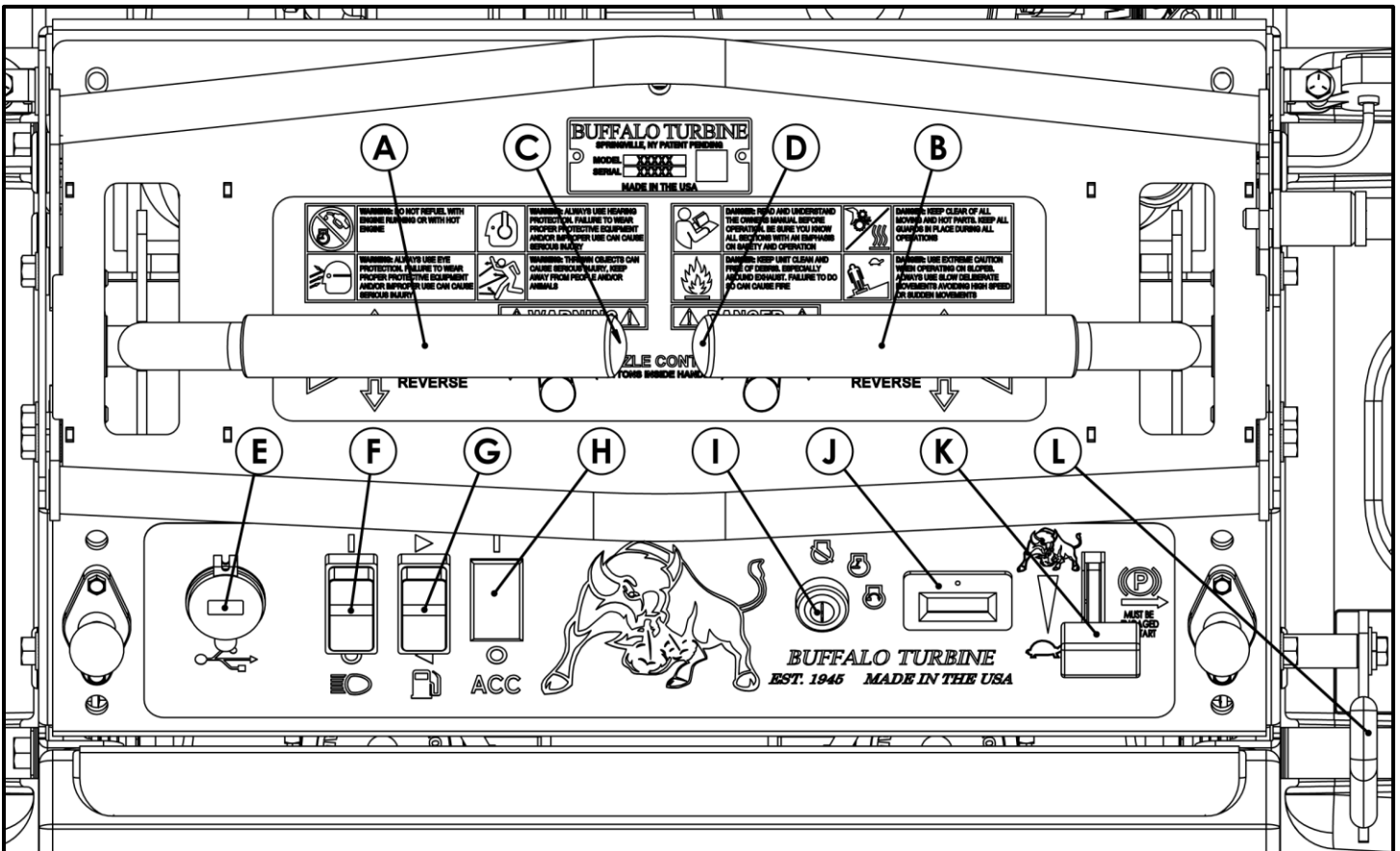

Adjusting the Operator's Platform

The operator platform can be adjusted for ride quality using the holes labeled 1 through 5. Hole 1 provides the softest ride, and hole 5 provides the stiffest ride.

To adjust the ride quality:

1. Remove the retaining clip and pin from the current hole.
2. Select and insert the pin into a different hole based on your desired ride quality.
3. Reattach the retaining clip to secure the pin.

Refer to the map below for the hole layout, ranging from soft [1] to stiff [5].

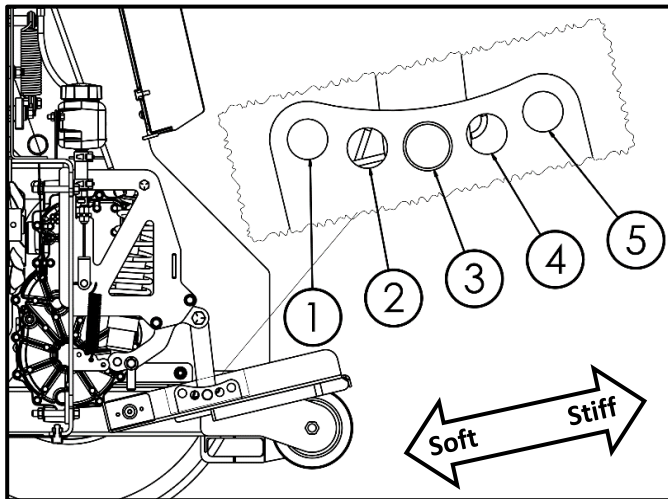
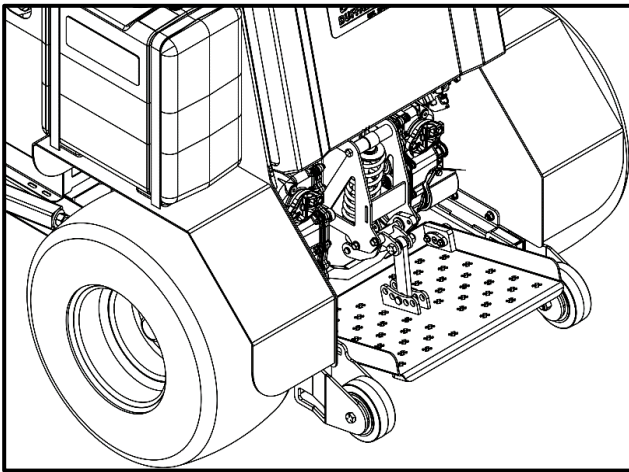

Adjusting the Stationary Arm

The stationary arm can be adjusted to limit the machine's speed or maintain a constant speed when using the blower. This adjustment is useful for training new operators, as it allows for speed restriction to enhance control and safety. Holes labeled 1 through 4 allow for stationary arm adjustment, with hole 1 providing no speed restriction and hole 4 offering a large speed restriction.

Directions:

1. Pull the spring-loaded pin handle [A] to retract the pin from the current hole.
2. Select the desired hole based on the speed setting you need and align the arm.
3. Release the spring pin to lock the setting in place.

Refer to the layout below for the adjustment options, ranging from no speed restriction [1] to the largest speed restriction [4].

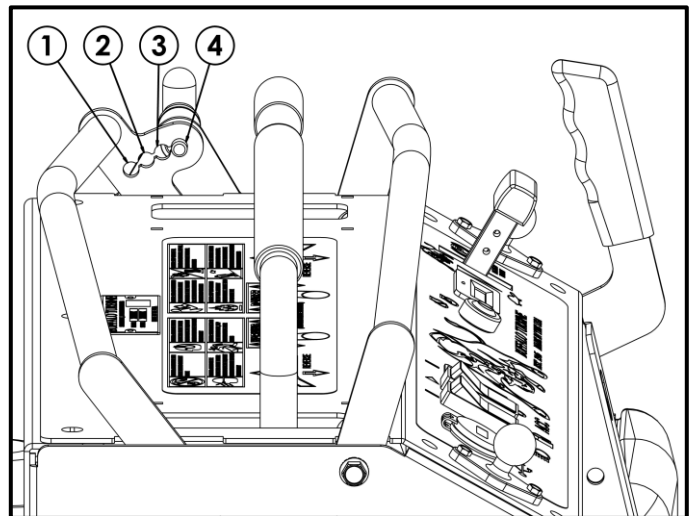
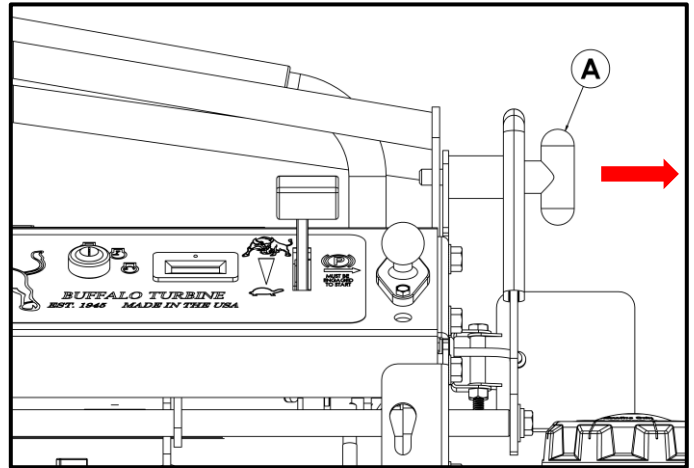

Removing the Leaning Pad

The leaning pad on the machine serves as a protective cover and ergonomic support for the operator, enhancing comfort during use. Removing the leaning pad provides necessary access to many of the machine's internal components, facilitating maintenance and adjustments.

Leaning Pad Removal:

1. Rotate the latch until it allows for leaning pad removal [1].
2. Slide the lifting pad up on the machine [2].

3. **Note:** Pins on the back of the leaning pad must align with the holes before the pad can be released. Hold the lifting pad up and pull away from the machine [3].

Leaning Pad Install:

1. Align and place the pins of the leaning pad into the holes visible from the back of the machine.
2. Allow the leaning pad to slide down into its resting position.
3. Rotate the latch until it locks the leaning pad from moving.

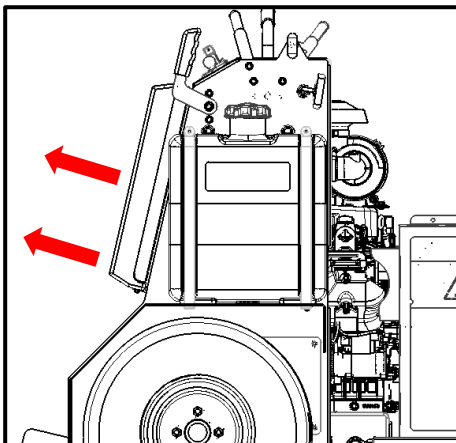
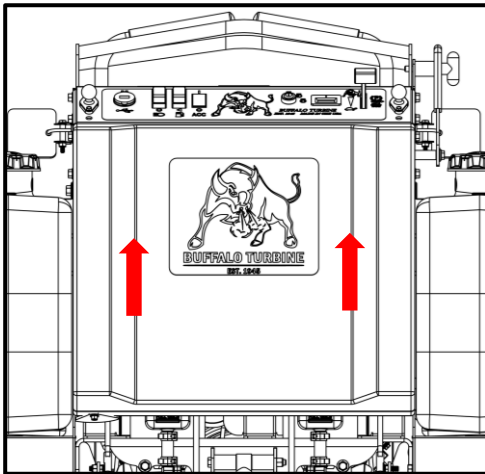
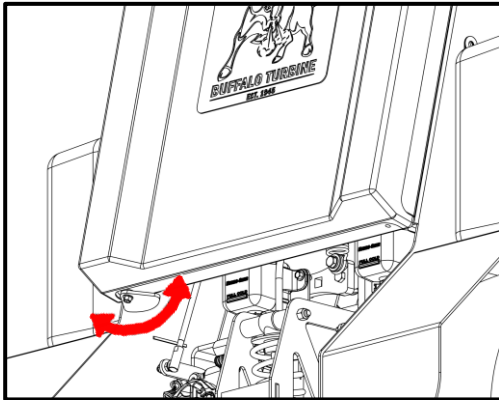

Adjusting/Testing the Parking Brake

The parking brake secures the machine when stationary. Regular testing is recommended to ensure it functions properly.

Directions:

1. Position the machine on a level surface.
2. Chock both the front and rear wheels.
3. Remove the key from the ignition.
4. Disengage the parking brake.
5. Remove the leaning pad and set aside.
6. Loosen, but do not disconnect, the parking brake cable bracket using a 9/16" wrench on both sides.
7. Adjust the parking brake cable by pushing the bracket downward.
8. Torque the bolt and nut to 40 ft-lbs securing the parking brake cable bracket.
9. Reattach the leaning pad.
10. Remove the chocks from the wheels.

Parking Brake Testing:

11. Engage the parking brake.
12. Attempt to push the machine forward and backward:
 - a. If the machine moves, further adjust the parking brake as needed.
13. Disengage the parking brake.
14. Attempt to push the machine forward and backward:
 - a. If the machine does not move, further adjust the parking brake as needed.

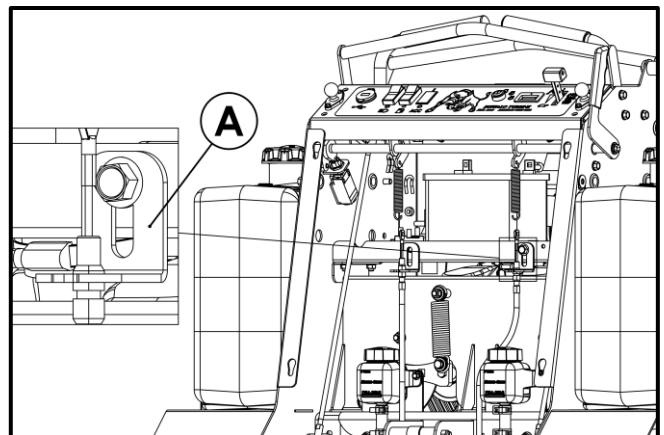

Adjusting the Motion Control Arms

The control arms can be adjusted to correct slack or limited travel. Make adjustments if the control arms contact the stationary arm when pushed forward or if they are more than 1/4" away from it when the stationary arm is in its farthest position.

- Allow the engine to cool completely before performing this adjustment.

Directions:

1. Stop the machine on a flat, level surface.
2. Apply the parking brake and remove the key from the ignition.
3. Remove the leaning pad and set aside.
4. Locate the linkage on the back of the machine, for the motion control arm that requires adjustment.
5. Remove the nyloc nut [E] from the heim joint end [D] using a 1/2" wrench on [D] and another 1/2" wrench on [E].
6. Pull the heim joint [D] out of the arm connected to the transaxle.
7. Release the jam nut [C] above [D] using a 1/2" wrench on [C] and another 1/2" wrench on [D].
8. Adjust the distance between the stationary arm [A] and the motion control arms [B]:
 - If the gap between the stationary arm and the motion control arm is greater than 1/4", loosen the heim joint end by one turn.
 - If the stationary arm is contacting the motion control arms, tighten the heim joint end by one turn.

Continue to Step 9 when desired adjustment is made.

9. Insert the heim joint end back into the arm connected to the transaxle.
10. Thread the nyloc nut on the heim joint end.
11. Torque to 17 ft-lbs.
12. Tighten jam nut back onto the heim joint end.
13. Reattach the leaning pad.

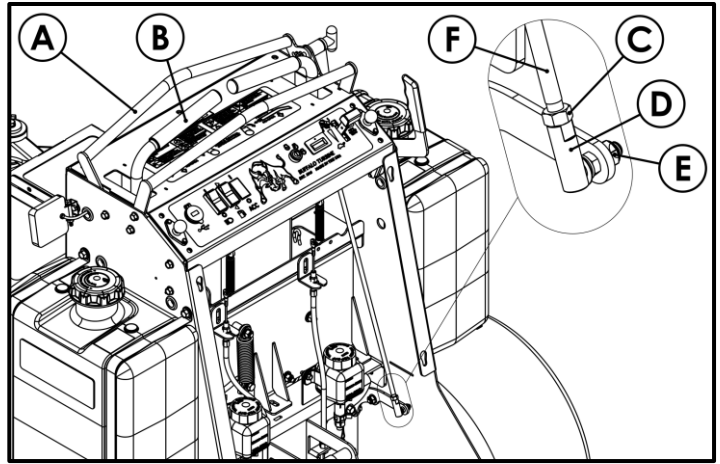

Test drive the machine to ensure all functionality of the motion control handles is restored and/or maintained.

Machine Specifications

Engine Specifications	
Model:	40HP EFI/ETC Engine
Type:	4-Stroke, EFI
Displacement:	993 cc (60.6 ci)
Cooling System:	Air-cooled
Oil Capacity:	78 - 80 oz (2.3 - 2.4 L)
Fuel Type:	Gasoline
Fuel Filter:	Replaceable Element Type
Spark Plug Gap:	0.030 in (0.76 mm)
Battery:	12 Volt, 340 CCA
Exhaust System:	Standard Exhaust

All values are referenced from the Engine Operator's Manual.

Chassis Specifications	
Fuel Tank Capacity:	2 x 8 gal Tanks, Total 16 gal
Overall Width:	47" (119.4 cm)
Overall Height:	52" (132 cm)
Overall Length:	90" (228.6 cm)
Overall Length (Nozzle Removed):	70" (177.8 cm)
Ground Clearance:	3 - 3/8" (8.6 cm)
Approximate Weight (Full Tanks):	943 lbs (428 kg)

Tire & Wheel Specifications	
Front Tire Size:	13 X 6.50 - 6
Rear Tire Size:	22 X 11.00 - 10
Front Tire Inflation Pressure:	15 psi (103.4 kPa) (1.03 bar)
Rear Tire Inflation Pressure:	8 psi (55.2 kPa) (0.55 bar)

Transaxles' Specifications	
Make:	Hydro-Gear
Model:	ZT-3100 Transaxles
Type:	Integrated Zero-Turn Transaxle
Oil Capacity:	2 x 2 qt (1.9 L), Total 4 qt (3.8 L)
Gear Ranges:	Infinitely Variable

All values are referenced from the Hydro-Gear ZT-2800®/ZT-3100®/ZT-3200™ Service Manual.

Fluids & Grease	
Engine Oil:	SAE 30 Oil
Grease:	Heavy Duty Grease
Transaxle Oil:	20W50 Engine Oil

Maintenance Schedule

Initial Maintenance Schedule for BT-SB40	
Once at 10 Hours	Completed: <input type="checkbox"/>
<ul style="list-style-type: none"> ● Check transaxles' oil level. ● Check parking brake operation. ● Check wheel lug nut torque. ● Check air pressure in tires. ● Check transaxles' drive belt. 	
Once at 50 Hours	Completed: <input type="checkbox"/>
<ul style="list-style-type: none"> ● Change the engine oil and filter during break-in period. ² 	
Once at 75 Hours	Completed: <input type="checkbox"/>
<ul style="list-style-type: none"> ● Change the transaxles' oil and filters during break-in period. 	
Regular Maintenance Schedule for BT-SB40	
Before Each Use	
<ul style="list-style-type: none"> ● Check the engine oil level. ● Check the tire air pressures. ● Clean visible debris from the blower, engine compartment, and cooling fins. 	
Every 25 Hours	
<ul style="list-style-type: none"> ● Grease front wheels. 	
Every 40 Hours	
<ul style="list-style-type: none"> ● Check transaxles' oil level. ● Check parking brake operation. ● Check wheel lug nut torque. ● Check air pressure in tires. ● Check transaxles' drive belt. 	
Every 100 Hours or Annually	
<ul style="list-style-type: none"> ● Clean or replace the air filter. ^{1,3} ● Check the muffler and spark arrester. ² ● Change the engine oil and filter. ² ● Replace the sparkplugs. ² ● Check the muffler and spark arrester. ² ● Service the exhaust system. ² 	
Every 250 Hours or Annually	
<ul style="list-style-type: none"> ● Check the valve clearance. Adjust if necessary. ² 	
Every 400 Hours or Annually	
<ul style="list-style-type: none"> ● Change the transaxles' oil and filters. ● Replace the fuel filter. ● Replace the air filter. ³ ● Service the air cooling system. ² 	

In hot weather (over 85°F/30°C) or dusty conditions, consider shorter intervals for maintenance processes marked with this symbol. ¹

Refer to the Engine Operator's Manual. ²

Every third air filter change, replace the inner safety filter. ³

Engine Maintenance

Consult the maintenance schedule and machine operator's manual for detailed engine maintenance schedules and procedures.

Transaxle Maintenance

Consult the maintenance schedule and machine operator's manual for detailed transaxle maintenance schedules and procedures.

Battery Maintenance

 **WARNING** Keep open flames and sparks away from the battery. When handling the battery, take care to avoid spilling battery acid, and always disconnect the negative cable first and reconnect it last to prevent short circuits.

Clean Battery Terminals and Cables:

Directions:

1. Remove the battery [*Removing and Installing the Battery*].
2. Clean the battery terminals and cable ends using a wire brush until they are free of corrosion and shiny.
3. Apply petroleum jelly or non-conductive grease to the cable ends and battery terminals to prevent corrosion.
4. Install the battery [*Removing and Installing the Battery*].

Check the Battery Voltage:

The battery voltage display should read approximately 12 volts when the engine is off, and between 13 to 14 volts when the engine is running, indicating that the charging circuit is functioning correctly.

Diagnosing Battery Issues:

A dead battery or one too weak to start the engine does not necessarily mean the battery needs replacement. Refer to the *Troubleshooting* Guide for more details, and if you're still unsure, contact your authorized dealer.

Charging the Battery:

 **WARNING** Keep open flames and sparks away from the battery; the gases emitted during operation and charging are highly explosive. Ensure adequate ventilation around the battery during charging.

Before charging the battery, it's important to understand that a weak or dead battery may be caused by a defect in the charging system or another electrical component. To ensure safety and proper function, always adhere to the battery charger manufacturer's instructions and follow all safety warnings.

When charging, monitor the process carefully to avoid overcharging, and continue charging until the battery is fully charged.

Jump Starting:

 **WARNING** Jump starting with an auxiliary (booster) battery is not recommended and should be avoided.

Lifting and Hoisting the Machine

Jack and Support Points:

This diagram illustrates the designated jack points and support points for the BT-SB40 to ensure proper lifting and stabilization during maintenance.

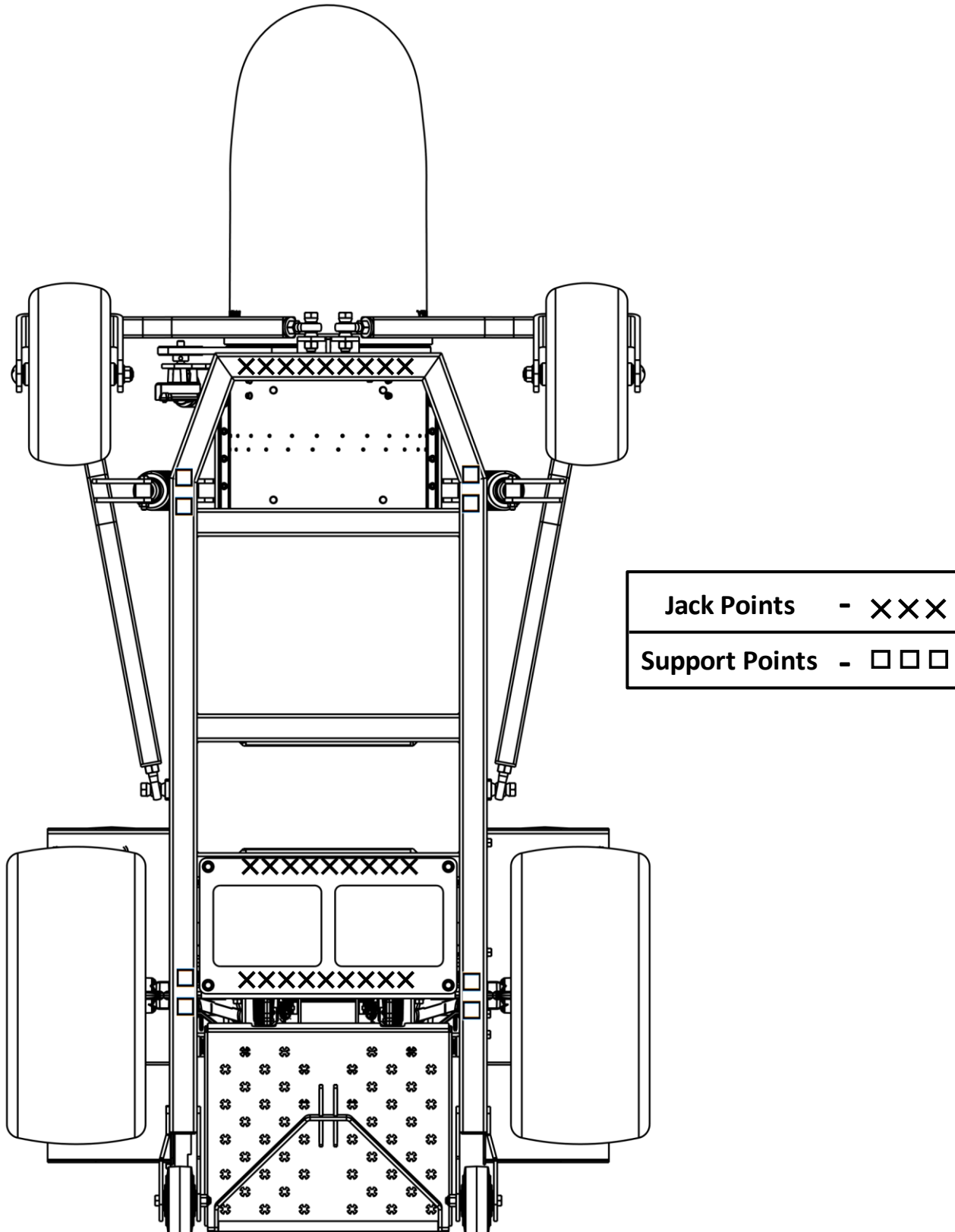

Hoist Pick-Up Points:

This diagram illustrates the designated hoisting points for the BT-SB40 to ensure proper lifting during maintenance.

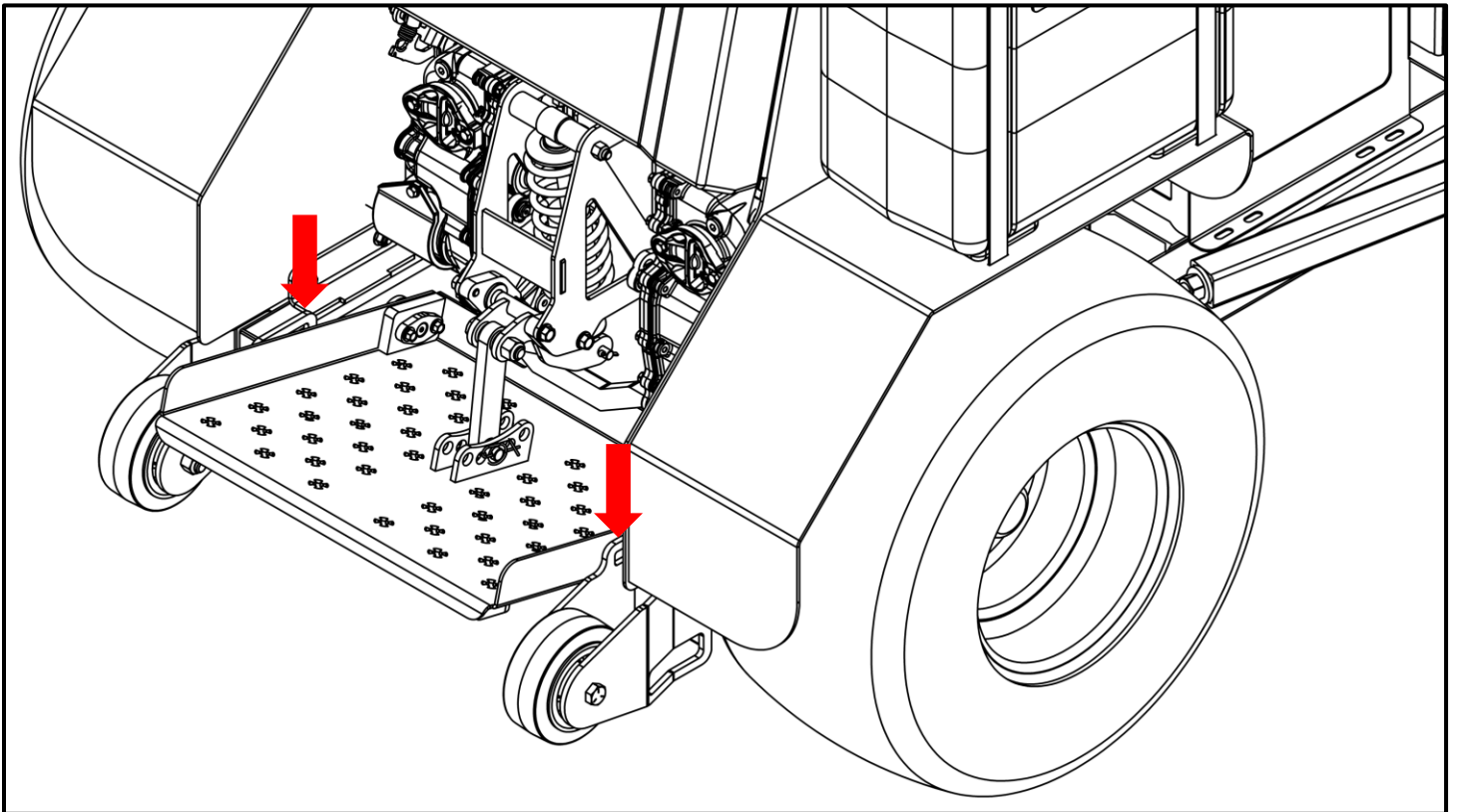
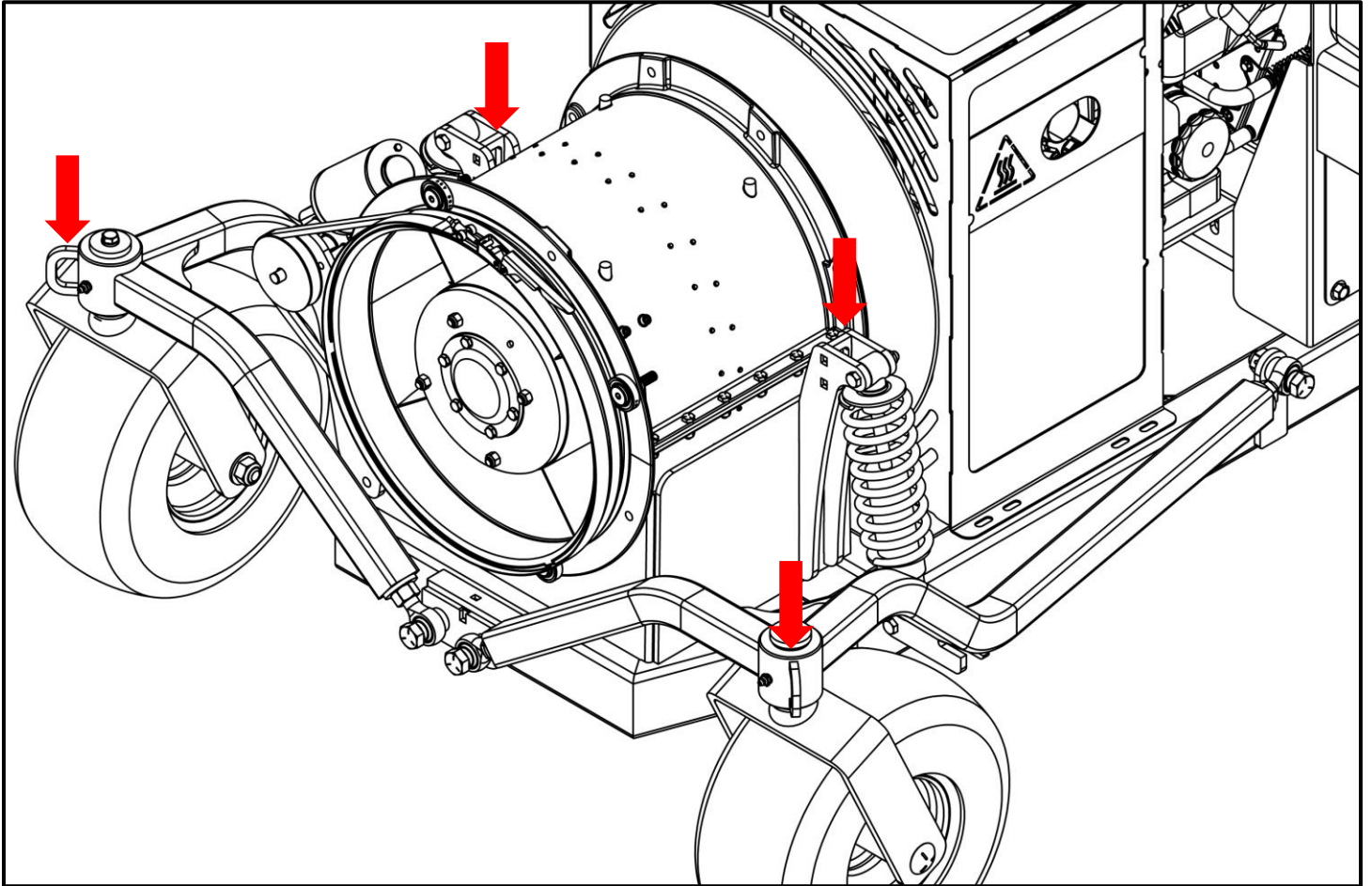

Engine Component Identification

Engine Oil Dip Stick: [A]

Oil Fill Cap: [B]

Drain Valve: [C]

Drain Hose: [D]

Oil Filter (Opposite Side of Engine): [E]

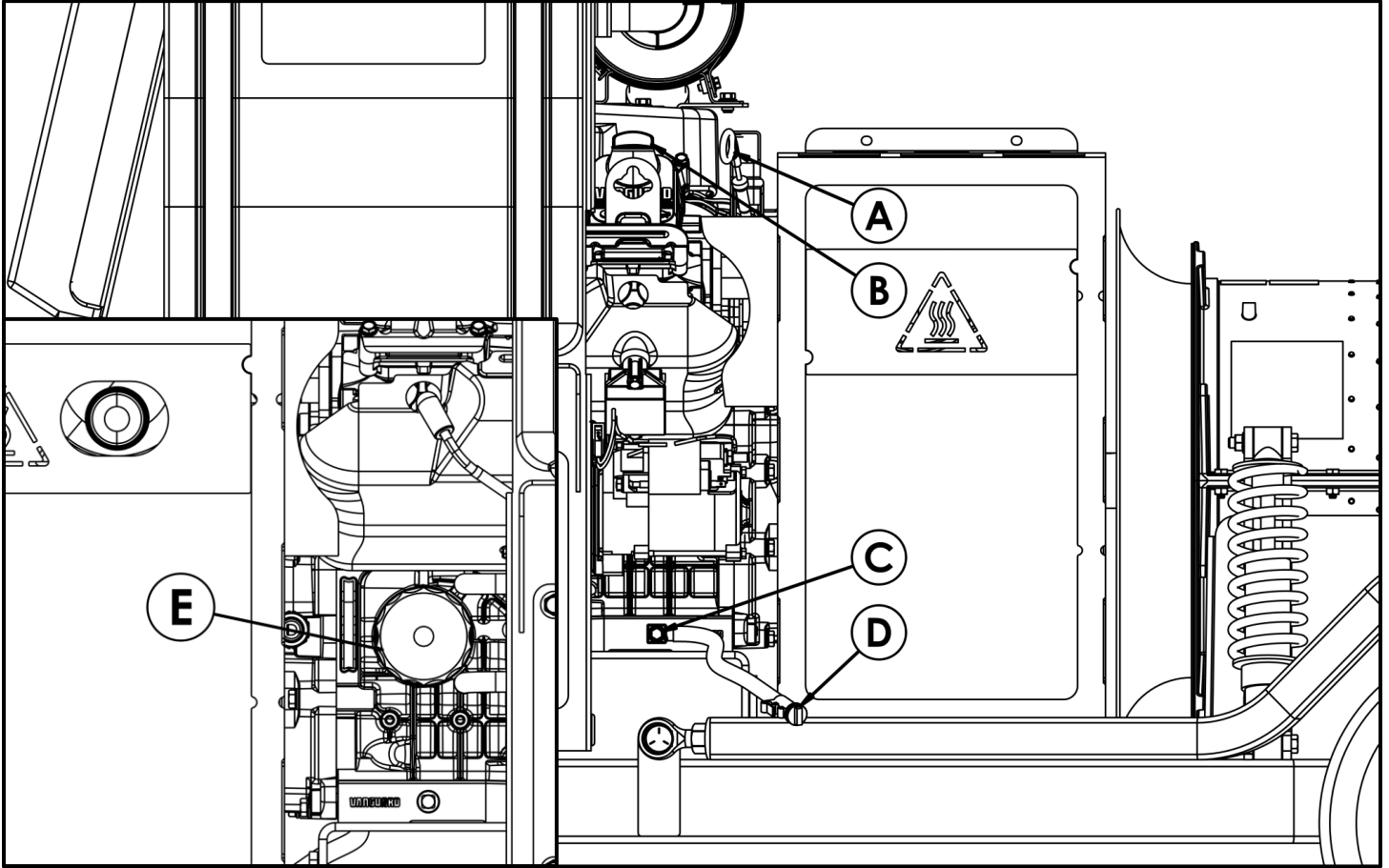

Transaxle Component Identification

Transaxle(s): [A]

Transaxle Oil Reservoir: [B]

Oil Reservoir Cap: [C]

Reservoir "FULL COLD" Fill Line: [D]

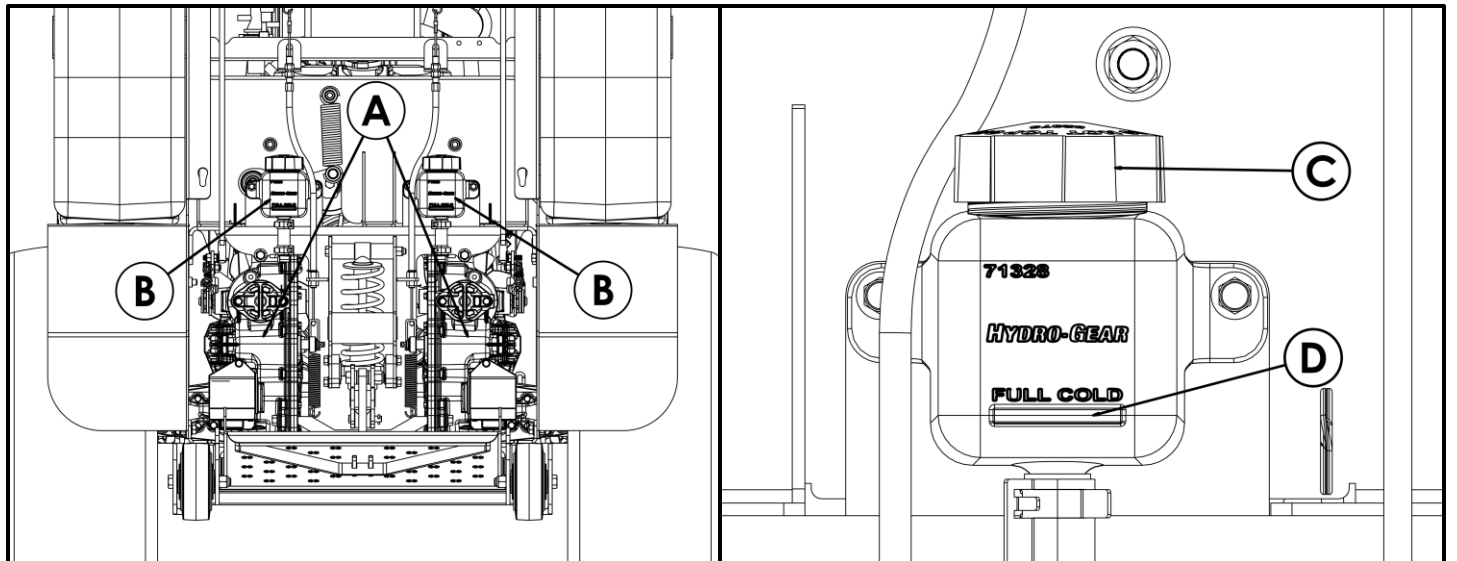

Fuse Box Location & In-Line Fuse Identification

Note: The following image shows the components located above the positive terminal on the battery.



Main Harness Fuse (30A): [A]

Fuel Reserve Fuse (10A): [B]

Fuse Box Component Identification

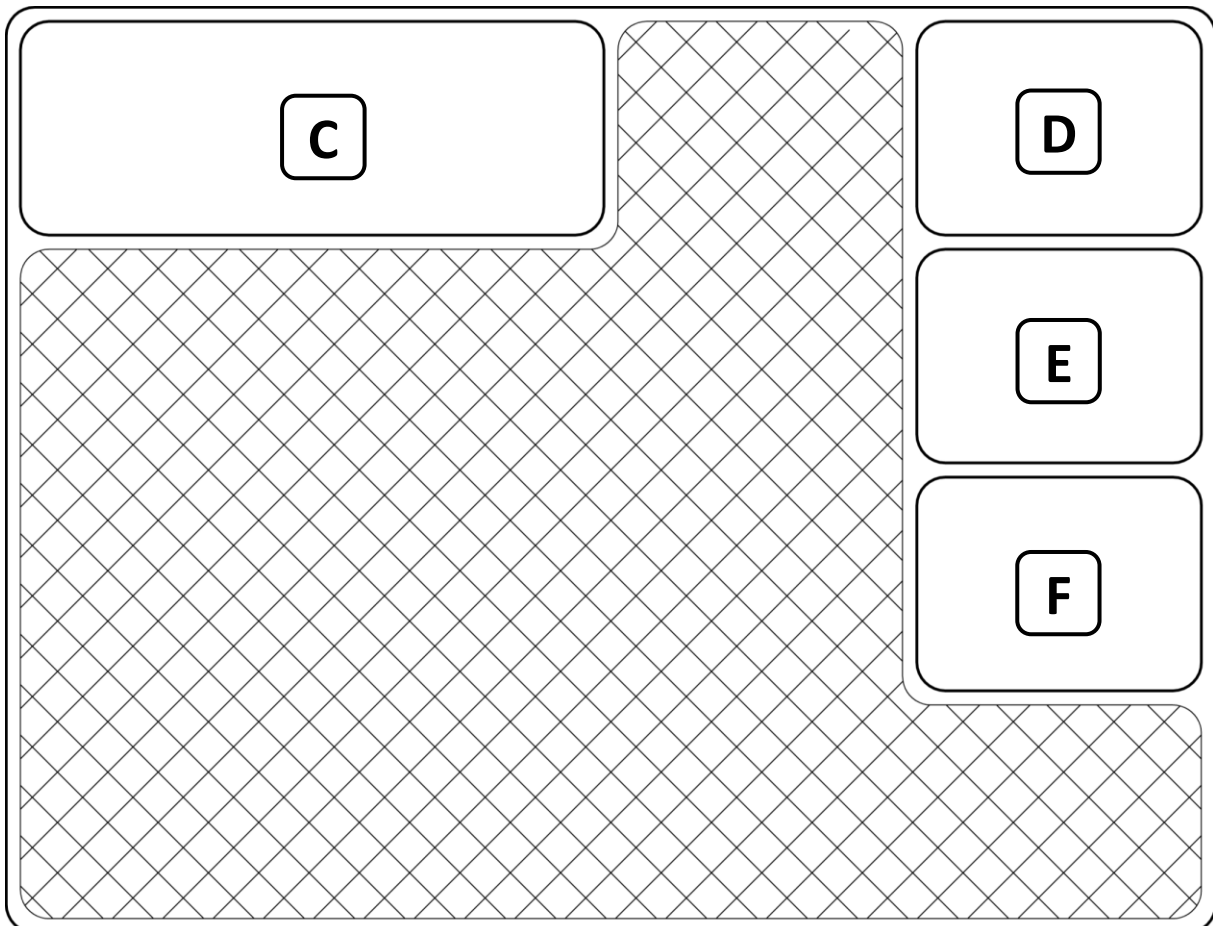

Ignition Relay: [C]

Contactor/Relay Fuse (10A): [D]

Headlights Fuse (10A): [E]

USB Auxiliary Port Fuse (5A): [F]

Checking/Adding Fuel

⚠ WARNING Gasoline is highly flammable and should be handled with caution.

- Allow the engine to cool for at least 3 minutes before refilling.
- Do not permit open flames, smoking, or matches in the vicinity.
- Avoid overfilling and clean up any spills immediately.
- Use a clean, approved non-metallic container to prevent static discharge.
- Always use a clean, approved non-metallic funnel equipped with a plastic mesh strainer when refilling the fuel tank.

Recommendation: Refuel at the end of each day to prevent condensation inside the fuel tanks.

Directions:

1. Position the machine on a flat, level surface.
2. Apply the parking brake and remove the key from the ignition.
3. Clear any dirt or debris from around the fuel cap area.
4. Remove the fuel cap slowly to release any built-up pressure in the tank.
5. Add fuel to the tank using a non-metallic funnel with a plastic mesh strainer. Fill only to the bottom of the filler neck and avoid overfilling. Clean up any spilled fuel immediately.
6. Secure the fuel cap after refilling.

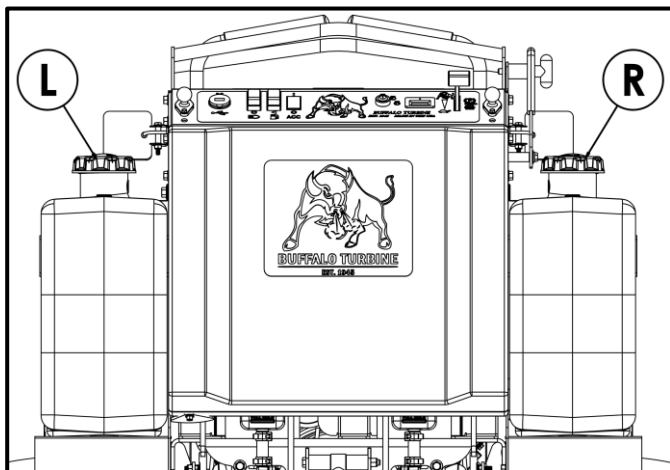

Checking Tire Pressure

⚠ WARNING Explosive Tire and Rim Separation Hazard. Improper handling of tire and rim assemblies can result in serious injury or death.

Tire pressures should be checked regularly and maintained according to the levels specified in *Machine Specifications*. These recommended pressures may differ slightly from the "Max Inflation" value stamped on the tire sidewall.

Following the specified pressures ensures optimal traction and helps extend tire life.

- Do not attempt to mount a tire without the proper equipment and experience.
- Always maintain the correct tire pressure and never exceed the recommended pressure in *Machine Specifications*.
- Never weld or apply heat to a wheel and tire assembly. Heat can increase air pressure, leading to a tire explosion, and can also weaken or deform the wheel.
- When inflating tires, use a clip-on chuck and an extension hose that allows you to stand to the side, away from the front or top of the tire assembly.
- Regularly inspect tires for low pressure, cuts, bubbles, damaged rims, or missing lug bolts and nuts.

Checking Engine Oil Level

Before you check or add oil:

- Ensure the engine is level.
- Clean the oil fill area of any debris.
- Refer to the *Machine Specifications* section for oil capacity.

Note: Before starting the engine for the first time, ensure the oil is at the correct level. Add oil as specified by the instructions in the manual. Starting the engine without oil will cause damage.

Directions:

1. Remove the dipstick [*Engine Component Identification, A*] and clean it with a cloth.
2. Reinsert the dipstick.

3. Ensure the oil is at the top of the full indicator on the dipstick. If the oil is below this level, proceed to the next step.
4. Add oil into the engine oil fill. [*Engine Component Identification, B*] Avoid overfilling.
5. Wait one minute and recheck the oil level. Ensure it is at the correct level.
6. Reinstall the dipstick.

* - Refer to the *Engine Operator's Manual*, page [6].

Checking/Adding Transaxles' Oil

Before you check or add oil:

- Ensure the machine is on a level surface.
- Clean the area around the transaxles' oil reservoirs to remove any dust, dirt, or debris.
- Make sure the machine is cold before proceeding.

Directions:

1. Remove the leaning pad from the machine and set it aside.
2. Locate the transaxles' oil reservoirs at the rear of the machine. [*Transaxle Component Identification, A*]
3. Ensure the oil is at the "FULL COLD" mark [*Transaxle Component Identification, C*] on each transaxle oil reservoir. If the oil is below this level, proceed to the next step.
4. Remove the cap(s) [*Transaxle Component Identification, B*] from the reservoir(s) below the "FULL COLD" mark.
5. Add oil up to the "FULL COLD" mark using 20W-50 oil.
6. Reinstall the reservoir caps securely.
7. Reattach the leaning pad.

Note: If oil has been changed or added, it may be necessary to purge air from the system. Refer to the purging procedures [*Air Purging the Transaxles*] if the machine is not driving properly after adding oil.

* - This procedure is adapted from the *Hydro-Gear ZT-2800®/ZT-3100®/ZT-3200™ Service Manual*, page [9].

Greasing the Machine

Grease Change Interval: Every 25 hours.

Tools & Supplies:

- Grease Gun
- Grease
- Rags

Directions:

1. Grease the fittings shown on the machine, using a grease gun, until new grease appears beneath the large washer above the fitting.
2. Clean excess grease from the machine using a rag.

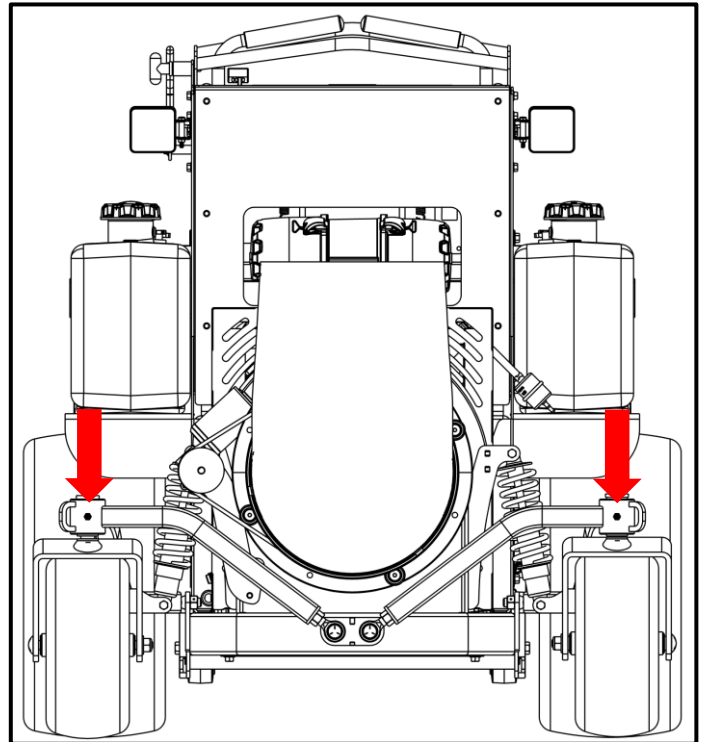

Changing the Engine Oil and Filter

Engine Oil and Oil Filter Change Interval: Every 100 hours or annually, whichever comes first.

Note: It is recommended to run the engine until the oil is warmed, as this helps it to drain more effectively. Once the oil has reached operating temperature, proceed with the *Changing the Engine Oil and Filter*.

Tools & Supplies:

- 10mm Wrench
- Oil Filter (842921) or Equivalent
- 2.4 – 2.5 qt (2,3 - 2,4 L) Oil (10W-30)
- Drain Pan
- Rags

Directions:

1. Apply the parking brake, remove the key from the ignition.
2. Disconnect the spark plug wires and keep them away from the spark plugs.
3. Move the drain hose [*Engine Component Identification, D*] from under the engine to the edge of the frame
4. Position a drain pan below the hose outlet.
5. Remove the engine oil dipstick [*Engine Component Identification, A*] to allow venting. *Do Not Discard*
6. Remove the cap from the oil drain hose.
7. **CAUTION** ⚠ Loosen the adapter valve [*Engine Component Identification, C*] connected to the drain hose using a 10mm wrench to allow the engine oil to drain into the pan.
8. While the oil is draining, place a rag below the engine oil filter [*Engine Component Identification, E*] on the frame.
9. After the oil has completely drained, close the adapter valve and reinstall the cap on the drain hose.
10. Remove the existing oil filter and discard it properly.
11. Lightly lubricate the gasket of the new oil filter with clean oil.
12. Install the new oil filter by hand, turn 3/4 to one full turn after the filter gasket contacts the engine surface.
13. Remove the oil fill cap. [*Engine Component Identification, B*] *Do Not Discard*
14. Ensure the oil fill cap area is clean. Slowly add the recommended amount of oil into the engine oil fill.
15. Clean the engine oil dipstick, and reinsert it to check the oil level. Ensure the oil level is at the top of the full indicator on the dipstick.
16. Reinstall and tighten the oil fill cap.
17. Reconnect the spark plug wires to the spark plugs.

18. Start the engine and let it run until warm, then check for any oil leaks.
19. Stop the engine and confirm the oil level is still correct on the dipstick. Adjust if necessary.

* - Refer to the Engine Operator's Manual, page [8].

Changing the Air Filter

Air Filter Change Interval: Every 400 hours or annually, whichever comes first.

Directions:

1. Apply the parking brake and remove the key from the ignition.
2. Undo the fasteners on the front and rear of the air cleaner [Figure 1].

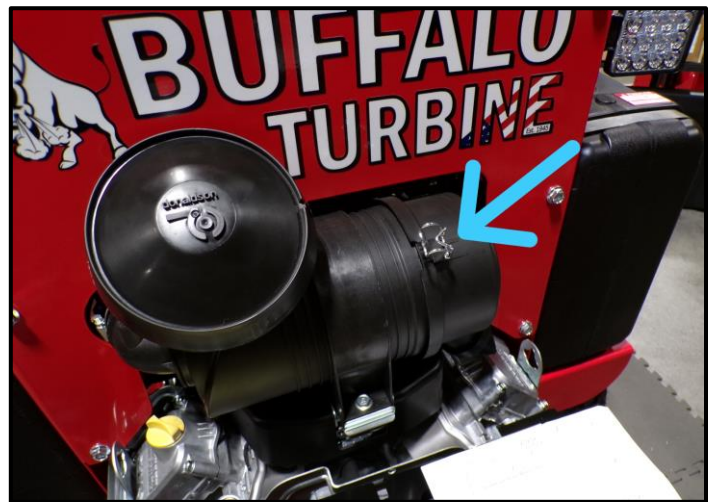

Figure 1 Air Cleaner Clamp

3. Remove the end cap from the air cleaner and pivot it to slip by the front panel using the process shown. [Figure 2]

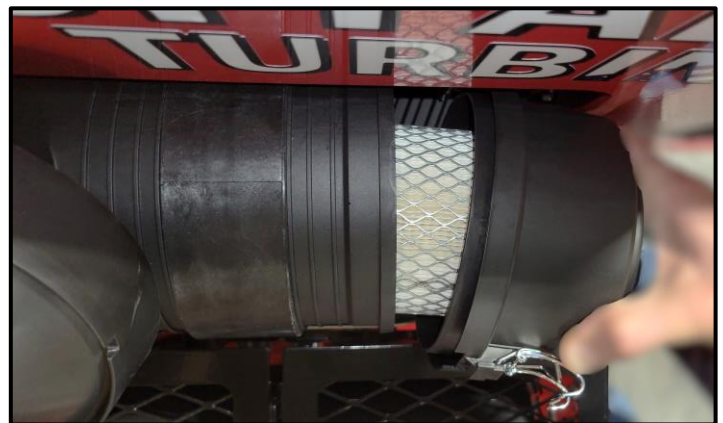

Figure 2 Air Filter Removal Process

4. Remove the existing air filter from within. **Note:** Orientation of air filter for when replacing.

5. **Note: Every 3rd Air Filter Change:**
 - a. Remove the blue safety filter. **Note:** Orientation of safety filter when replacing.
 - b. Reinsert the new safety filter.
6. Reinsert the new air filter into the air cleaner.
7. Reattach end cap onto air cleaner.
8. Clamp the rear fastener on the air cleaner cap within the machine.
9. Clamp the exposed fastener on the air cleaner cap.

Changing the Fuel Filter

WARNING

Gasoline is highly flammable and explosive. You can be burned or seriously injured when handling fuel.

- Stop the engine and keep heat, sparks and flame away.
- Refuel only in a well ventilated area.
- Wipe up spills immediately.

Fuel Filter Change Interval: Every 400 hours or annually, whichever comes first.

Note: If this is being performed as scheduled maintenance and the fuel filter is operational, it is recommended to run a fuel tank until the engine stalls from lack of fuel. At that point continue to *Changing the Fuel Filter*.

Tools & Supplies:

- Diagonal Cutting Pliers
- Pliers
- Zip Ties

Directions:

1. Allow the engine to cool for at least 3 minutes.
2. Disconnect the battery. [*Disconnecting and Connecting the Battery*]
3. Clip the (2) zip ties securing the fuel lines [Figure 3] on either side of the fuel filter using a pair of diagonal cutting pliers.
4. Slide both hose clamps on the fuel lines away from the fuel filter using pliers.

5. Place a rag below the fuel filter to catch any fuel spillage.
6. **CAUTION** Disconnect the lower fuel line from the fuel filter.
7. Disconnect the upper fuel line from the fuel filter and remove the existing fuel filter from the machine. **Note:** Orientation of the fuel filter for when replacing.
8. Connect the upper fuel line to the new fuel filter's inlet, ensuring the correct orientation:
 - a. If marked, align the filter's directional arrow with the fuel flow.
 - b. If unmarked, match the orientation to the removed filter.
9. Connect the lower fuel line to the outlet of the filter.
10. Slide both hose clamps back up over the barbs on both sides of the fuel filter to secure the fuel lines in place using pliers.
11. Secure the fuel lines to the panel with new zip ties in the same locations as the ones removed.

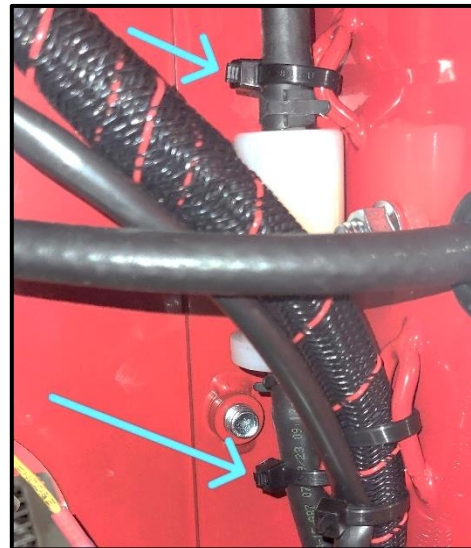

Figure 3 Zip Ties Securing Fuel Filter

12. Turn the ignition switch ON for two seconds, then OFF for 10 seconds.
13. Turn the ignition switch back to ON and check for fuel leaks.
14. Reconnect the battery. [*Disconnecting and Connecting the Battery*]

Changing the Transaxles' Oil and Filters

Oil & Filter Change Interval: Perform an initial oil and filter change at 75-100 hours, followed by changes every 400 hours thereafter.

Tools & Supplies:

- | | |
|-----------------------------|--------------------------------|
| • 11/16" Wrench | • 3/8" Socket |
| • Ratchet | • 1/4" Hex Bit Socket |
| • Torque Wrench (35 ft-lbs) | • 4qts. Oil (20W-50) |
| • 11/16" Crow's Foot | • Wheel Chocks |
| • 9/16" Socket | • Oil Filter (52114) or Equiv. |
| • Drain Pan | • Floor Jack or Hoist |
| • 3"+ Extension | • Jack Stands (1,000+ lbs.) |
| Optional | • Oil Filter Wrench |

Directions:

1. Apply the parking brake and remove the key from the ignition.
2. Chock the front wheels.
3. Engage the bypass valve on both transaxles.
4. Lift the rear end of the machine through either of the methods shown in the guide. [Lifting and Hoisting the Machine]

Note: Never work under a jack or hoist. Always support heavy objects that have been raised with appropriate jack stands or other suitable equipment rated for the weight of the object being lifted.

5. Remove the black guard on the underside of the machine using a 9/16" socket and ratchet.
6. Place a drain pan below drain bolts. **Note:** There is a drain bolt on each of the transaxles.
7. Loosen and remove one drain bolt [Figure 7] using an 11/16" wrench. **Recommendation:** Drain one transaxle at a time.



Figure 7 Drain Bolt on Transaxle

8. Loosen and remove the opposite drain bolt.
9. Remove and set aside the leaning pad from the machine.
10. Remove the filter guards [Figure 4] using a 3/8" socket, extension, and ratchet as shown.

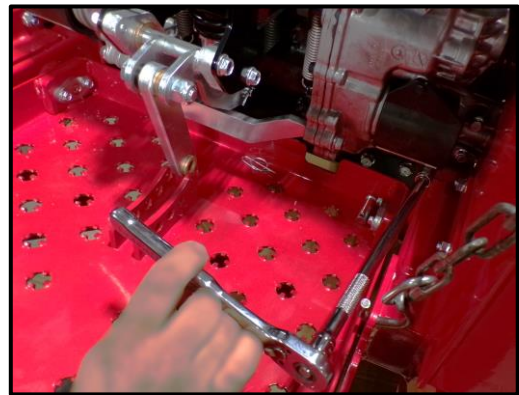

Figure 4 Filter Guard on Machine

11. Remove the old filters [Figure 5] using filter wrench as shown if required.

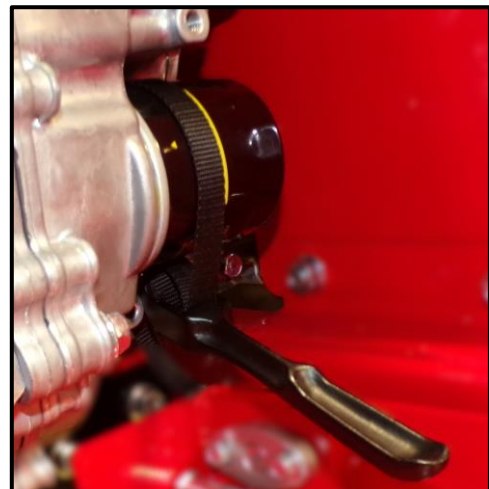

Figure 5 Oil Filter Removal

12. Remove the plugs from the location shown [Figure 6] using a 1/4" Hex Bit Socket and ratchet. ***Do Not Discard*** **Note:** This should help the transaxles drain completely.

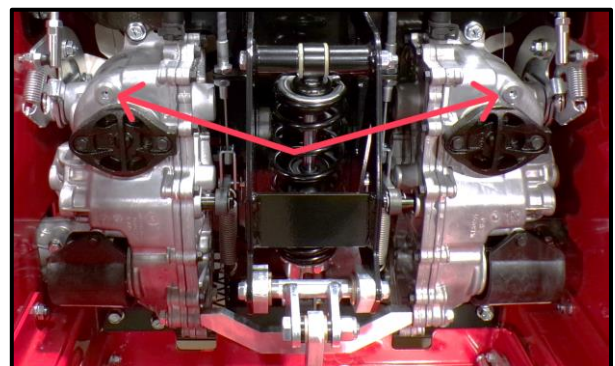

Figure 6 Plug Locations on Transaxle

13. **Note:** Repeat the following steps for each of the transaxles after they have drained completely:

- a. Wipe the mating filter surface on the transaxle clear of debris and used oil.
- b. Wipe oil on the gasket of the new filter.
- c. Install the new oil filter by hand, turn 3/4 to one full turn after the filter gasket contacts the transaxle surface.
- d. Reinstall the filter guards using a 3/8" socket and ratchet.
- e. Torque filter guard bolts to 9.3 ft-lbs (13 N·m).
- f. Reinstall drain bolt.
- g. Torque the drain bolt to 10 ft-lbs (13.6 N·m).
- h. Remove the cap from the reservoir atop the transaxle. ***DO NOT DISCARD***
- i. Fill the reservoir with 20W-50 until the oil reaches the plug hole from Step 12.
- j. Reinstall the top plug for the side of the transaxle that is being filled with oil.
- k. Torque the top plug to 18 ft-lbs (24.4 N·m).
- l. Fill the reservoir with oil up to the cold fill line.

14. Reinstall the bottom guard. **Recommendation:** Start all bolts by hand and then torque to 35 ft-lbs. (47.4 N·m)

15. Reattach the leaning pad.

16. Proceed to the purge procedure on the following page.

* - This procedure is adapted from the Hydro-Gear ZT-2800®/ZT-3100®/ZT-3200™ Service Manual, page [11].

Air Purging the Transaxles

Due to the effects air has on efficiency in hydrostatic drive applications, it is critical to purge it from the system. Air creates inefficiency because its compression and expansion rate is higher than that of the oil approved for use in hydrostatic drive systems. Implement these purge

procedures any time a hydrostatic system has been opened for maintenance or the oil has been changed.

Resulting symptoms in hydrostatic systems may include:

- Noisy operation
- Lack of power or drive after short-term operation
- High operating temperature and excessive expansion of oil

Before starting, ensure the transaxle is at the proper oil level. If it is not, fill to the specifications outlined in this manual.

Perform the following procedures with the vehicle drive wheels off the ground, then repeat under normal operating conditions. If this is not possible, perform the procedure in an open area free of any objects or bystanders.

1. Disengage the brake if activated.
2. Repeat until all the air is completely purged from the transaxle.

- a. Pull the bypass valve ring to the position [Figure 8].



Figure 8 Transaxle Bypass Valve Engaged

- b. Reinsert the key and start the engine.
- c. Slowly move the motion control in both forward and reverse directions (5 or 6 times).

d. Close the bypass valve as shown [Figure 10].

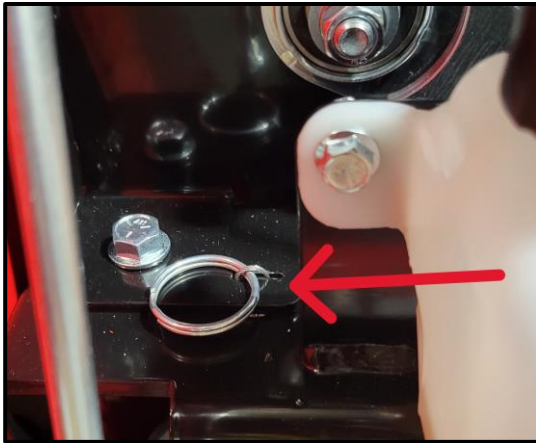

Figure 10 Transaxle Bypass Valve Disengaged

- e. Slowly move the motion control in both forward and reverse directions (5 or 6 times).
- f. Stop the engine.
- g. Check the oil level.
- h. Add oil as required to meet the cold fill line on the reservoirs.
- i. **Note:** Transaxle is purged when it operates at normal noise levels and moves smoothly in forward and reverse at normal speeds. IF NOT, repeat Step 2.

* - This procedure is adapted from the Hydro-Gear ZT-2800®/ZT-3100®/ZT-3200™ Service Manual, page [12].

Disconnecting and Connecting the Battery

Tool & Supplies:

- 1/2" Socket
- Extension of 6" or more
- Ratchet
- Torque Wrench

Disconnect

1. Engage the parking brake and remove the key from the ignition.
2. Remove the leaning pad from the machine and set it aside.
3. Remove the nut from the bolt holding the cables to the negative terminal as shown in [Figure 9] using a 1/2" socket, socket-driving wrench, and extension of at least 6".



Figure 9 Removing Negative Terminal from Battery

4. Leave the bolt in the cable ends, pull the cables away from the battery, and reinstall the nut on the end of the bolt.
5. Remove the nut from the bolt holding the cables to the positive terminal using the same tool combination from Step 3.
6. Leave the bolt in the cable ends, pull the cables away from the battery, and reinstall the nut on the end of the bolt. **Ensure** both cables are clear of the battery terminals and each other.

Reconnect

1. Remove the nut from the bolt in the end of the positive battery cable.
2. Insert the bolt through the positive terminal of the battery and fully thread the nut back onto the bolt.
3. Tighten the nut onto the bolt of the positive terminal using a 1/2" socket, torque wrench, and extension of at least 6". Torque to 15 ft-lbs (20.3 N·m).
4. Remove the nut from the bolt in the end of the negative battery cable.
5. Insert the bolt through the negative terminal of the battery and fully thread the nut back onto the bolt.
6. Tighten the nut onto the bolt of the negative terminal using the same tool combination from Step 3. Torque to 15 ft-lbs (20.3 N·m).

Removing and Installing the Battery

Tool & Supplies:

- 1/2" Socket
- Extension of 6" or more
- Ratchet
- Torque Wrench (15 ft-lbs)

Removal

1. Chock the wheels.
2. Disengage the parking brake, remove the key from the ignition, and remove the leaning pad from the machine.
3. Remove the nut from the bolt holding the cables to the negative terminal as shown in [Figure 9] using a 1/2" socket, socket-driving wrench, and extension of at least 6".
4. Leave the bolt in the cable ends, pull the cables away from the battery, and reinstall the nut on the end of the bolt.
5. Remove the nut from the bolt holding the cables to the positive terminal using the same tool combination from Step 3.
6. Leave the bolt in the cable ends, pull the cables away from the battery, and reinstall the nut on the end of the bolt. **Ensure** both cables are clear of the battery terminals and each other.
7. Remove the spring from the top of each parking brake cable, then engage the parking brake to move the links and springs up out of the way.
8. Release the clamp on the battery strap and loosen the strap several inches, leaving it connected to itself. Slide the strap off to the side of the battery.
9. Grasp the battery firmly with both hands, turn it sideways, and pull it out toward you. **Note:** Do not allow the battery terminals to contact the parking brake shaft, the underside of the control panel, or any other surface when handling the battery.

Install

1. **Note:** Skip if reinstalling the same battery. Compare the new battery to the removed one to confirm matching size and performance rating [Machine Specifications].

2. Grasp the new battery with both hands, turn it sideways to fit between the parking brake shaft and the battery tray, slide it into the battery compartment, then rotate it into the orientation shown in [Figure 11] and lower it into place.



Figure 11 Reinserting Battery into Battery Tray

3. Slide the strap back into place, center it over the battery, and pull it snug.
4. Remove the nut from the bolt in the positive battery cable end by hand and insert the bolt through the positive terminal of the battery. Fully thread the nut back onto the bolt.
5. Tighten the nut onto the bolt of the positive terminal using a 1/2" socket, torque wrench, and extension of at least 6". Torque to 15 ft-lbs (20.3 N·m).
6. Remove the nut from the bolt in the negative battery cable end by hand and insert the bolt through the negative terminal of the battery. Fully thread the nut back onto the bolt.
7. Tighten the nut onto the bolt of the negative terminal using the same tool combination from Step 5. Torque to 15 ft-lbs (20.3 N·m).
8. Disengage the parking brake to lower the links and springs, then reattach the lower hook of each spring to the loop at the top of its respective parking brake cable. Engage and disengage the parking brake and ensure it functions properly. Adjust parking brake with [Adjusting/Testing the Parking Brake] if necessary.
9. Reattach the leaning pad
10. Remove the wheel chocks.

Changing the Drive Belt

Tool & Supplies:

- Jack or Hoist
- Jack Stands for 1000+ lbs.
- 1/2" Drive Breaker Bar
- 1/2" Drive Ratchet
- 13/16" Socket
- 9/16" Socket
- (2) 9/16" Wrenches
- Torque Wrench
- Marker

Directions:

1. Park the machine on flat, level ground, shut it off and remove the key from the ignition.
2. Chock the front wheels, and disengage the parking brake.
3. Remove the leaning pad and set it aside.
4. Remove the left, upper parking brake spring from the top of the left parking brake cable.
5. Locate the parking brake cable brackets that are bolted to the face of the battery tray, and use a marker to mark the location of the bolt head in the left cable bracket, as shown [Figure 13].



Figure 13 Parking Brake Cable Bracket Location Marked

6. Use a pair of 9/16" wrenches to remove the bolt and nut holding the left cable bracket to the battery tray and set it aside.
7. Use a 13/16" socket on the 1/2" drive breaker bar to break loose all four lug nuts on each rear wheel (Break loose, but leave snug).
8. Lift the rear end of the machine through either of the methods shown in the guide. [*Lifting and Hoisting the Machine*]

Note: Never work under a jack or hoist. Always support heavy objects that have been raised with appropriate jack stands or other suitable equipment rated for the weight of the object being lifted.

9. Use the 13/16" socket and ratcheting wrench to remove lug nuts from each wheel, then remove both wheels and set them aside.
10. Use a 9/16" socket and ratcheting wrench to remove the eight bolts holding the two access panels in place (located inboard of each rear wheel), and set the access panels and fasteners aside.
11. Insert the square drive of the 1/2" drive breaker bar into the square opening of the tensioner arm, as shown [Figure 12]. Ensure the wrench's drive is fully seated into the tensioner before attempting to relieve tension.

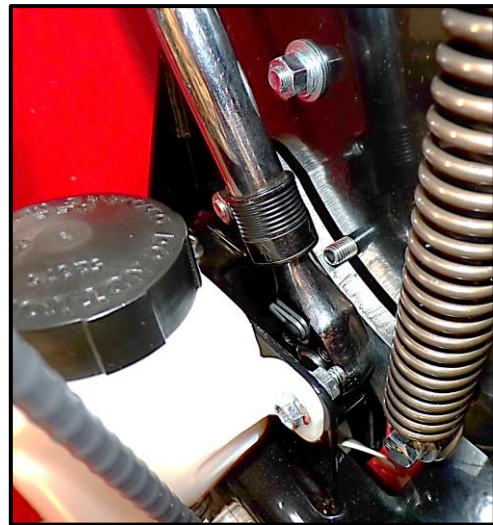

Figure 12 Breaker Bar on Tensioner Arm

12. Look through the access panel to find a 3/8" diameter hole in the black plate that the pulleys are bolted to, just under the tensioner arm.
13. Position yourself in the area where the left tire was, and use the 1/2" drive wrench to relieve tension off the drive belt (it takes several pounds of force to overcome the spring that keeps tension on the belt).
14. With the tensioner arm held in the relief position, fully insert one of the bolts removed in Step 10 through the hole in the black plate located in Step 12. Once the bolt is fully seated in the hole, slowly reduce the force applied to the breaker bar until the tensioner arm rests against the bolt.
15. With the tensioner arm securely restrained, the belt should be relieved of all tension. Reach an arm

through the access panel and confirm that the belt is slack.

16. Remove the old drive belt from the machine, and compare it to the new belt to ensure that belt length and profile are the same.
17. Clean debris from belt compartment.
18. Install the new drive belt, routing it around each pulley in the fashion shown in the diagram below, where 'CS' represents the pulley mounted on the engine's output shaft.

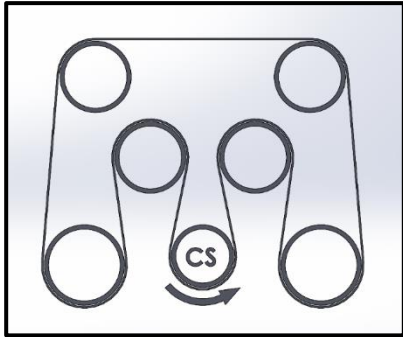

Figure 14 Drive Belt Layout

19. Once again insert the square drive of the ½" drive breaker bar into the square opening of the tensioner arm, as shown [Figure 12]. Ensure the wrench's drive is fully seated into the tensioner before attempting to relieve tension.
20. Apply force to the end of the breaker bar until the tensioner arm is no longer resting on the bolt inserted in Step 14, then remove the bolt and carefully relieve the force applied to the wrench.
21. Check all seven pulleys to ensure the belt is properly engaged with and centered over each one.
22. Reinstall both access panels, then torque each fastener to 35 ft-lbs (47.5 N·m).
23. Reinstall both rear wheels, and snug the lug nuts up.
24. Using a hoist or jack, lift the machine up off the jack stands and set the stands aside.
25. Lower the machine down onto its tires, remove the hoist or jack, then torque each lug nut to 90 ft-lbs (122 N·m).
26. Reinstall parking brake bracket using the same hardware that was removed.

27. Use the mark made on the bracket in Step 5 to place the bracket in the same position it was in before it was removed, then tighten it down. Torque the fastener to 40 ft-lbs. (54.2 N·m)
28. Reinstall the left, upper parking brake spring to the upper loop of the left parking brake cable, then engage and disengage the parking brake and ensure the parking brake is functioning properly. Adjust parking brake with [Adjusting/Testing the Parking Brake] if necessary.
29. Reinstall leaning pad, and remove wheel chocks.

Removing and Installing the Guard

Tool & Supplies

- 7/16" Wrench
- Torque Wrench
- 7/16" Socket
- Marker
- Ratchet

Removal:

1. Remove the hardware from the top of the guard using a 7/16" socket, ratchet, and 7/16" wrench. *Do Not Discard*
2. **Note:** Observe the order of hardware when removing. Remove the bolts from the bottom of the guard using a 7/16" socket and ratchet, keeping the wire clamp attached to the harness. *Do Not Discard*
3. Remove the guard halves and set them aside. **Note:** Guard halves are different and are not interchangeable.

Installation:

4. Position the guard halves on the machine, ensuring they are correctly oriented and aligned with the threaded holes.
5. Insert the bolts through the bottom of the guard into the frame and hand-tighten them using a 7/16" socket and ratchet.
6. Insert the hardware into the top of the guard and hand-tighten using a 7/16" socket, ratchet, and 7/16" wrench.
7. Torque all bolts to 8 ft-lbs (10.8 N·m).
8. Verify that the guard is securely installed and that the wire is properly clamped in place.

Guard Identification

Right Side Guard: [A]

Left Side Guard: [B]

- Harness runs along this guard flange

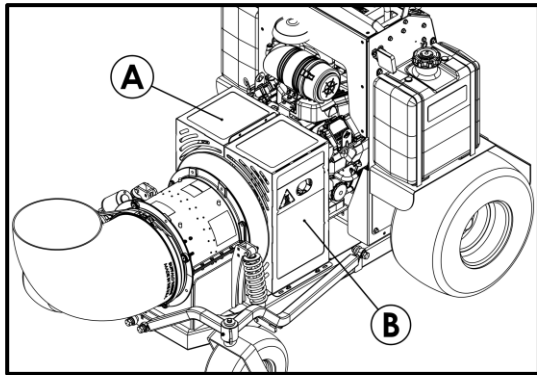

Removing and Installing the Nozzle

Removal

1. Move the lock from over the handle [A] on the clamp band.

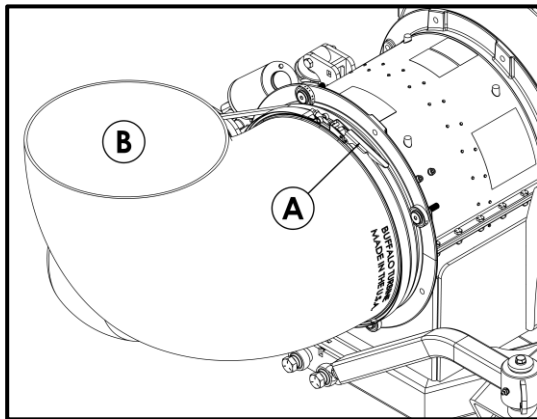

2. Pull [A] to release the clamp band from around the base ring and nozzle flange.
3. Set aside both the nozzle [B] and clamp band.

Install

1. Place the open clamp band around the base ring.
2. Slip the nozzle flange into the clamp band.
3. Press and lock the handle [A] to tighten the clamp band securing the nozzle [B] to the base ring.

Cleaning with Pressurized Air and Water

 **WARNING** Wear protective clothing, shoes, and eye protection (goggles or face shield) to prevent injury from debris or hot water.

Note: During cleaning, cover all electrical components to shield them from water exposure, and avoid spraying water directly onto these components or sensitive engine parts to prevent water damage. Do not use pressurized air or water on the blower's internal components, as this can cause damage.

When cleaning the machine, it is crucial to adhere to specific pressure limits to prevent damage to the machine's components:

- **Air Pressure:** Keep air pressure below 30 psi (205 kPa) to avoid damaging parts.
- **Water Pressure:** Use a garden hose to wash down the machine. DO NOT expose electrical systems or engine to high water pressures to protect those systems from damage.

Spot Cleaning:

Use a damp cloth for sensitive areas, particularly around electronic components, to minimize water exposure. Begin cleaning with less sensitive areas and finish with more delicate components.

Cleaning the Blower

 **DANGER** Operating the machine without the guard in place is highly dangerous and strictly prohibited. After blower cleaning, the guard must be reinstalled before using the machine.

Note: Avoid using pressurized air or water on the blower's internal components. Instead, use the following method to ensure safe and effective cleaning.

To clean the blower, first remove the guard and nozzle to gain better access to the blower's internal components. Refer to *[Removing and Installing the Guard]* and *[Removing and Installing the Nozzle]* for instructions.

Once the guard and nozzle are removed, use running water from a standard garden hose to clean the blower, avoiding high-pressure water to prevent damage. Gently scrub the blower with a soft-bristled brush to remove any debris or buildup, taking care not to apply excessive force.

After cleaning, ensure that both the guard and nozzle are securely reinstalled before operating the machine.

BT-SB40 MAIN WIRING HARNESS

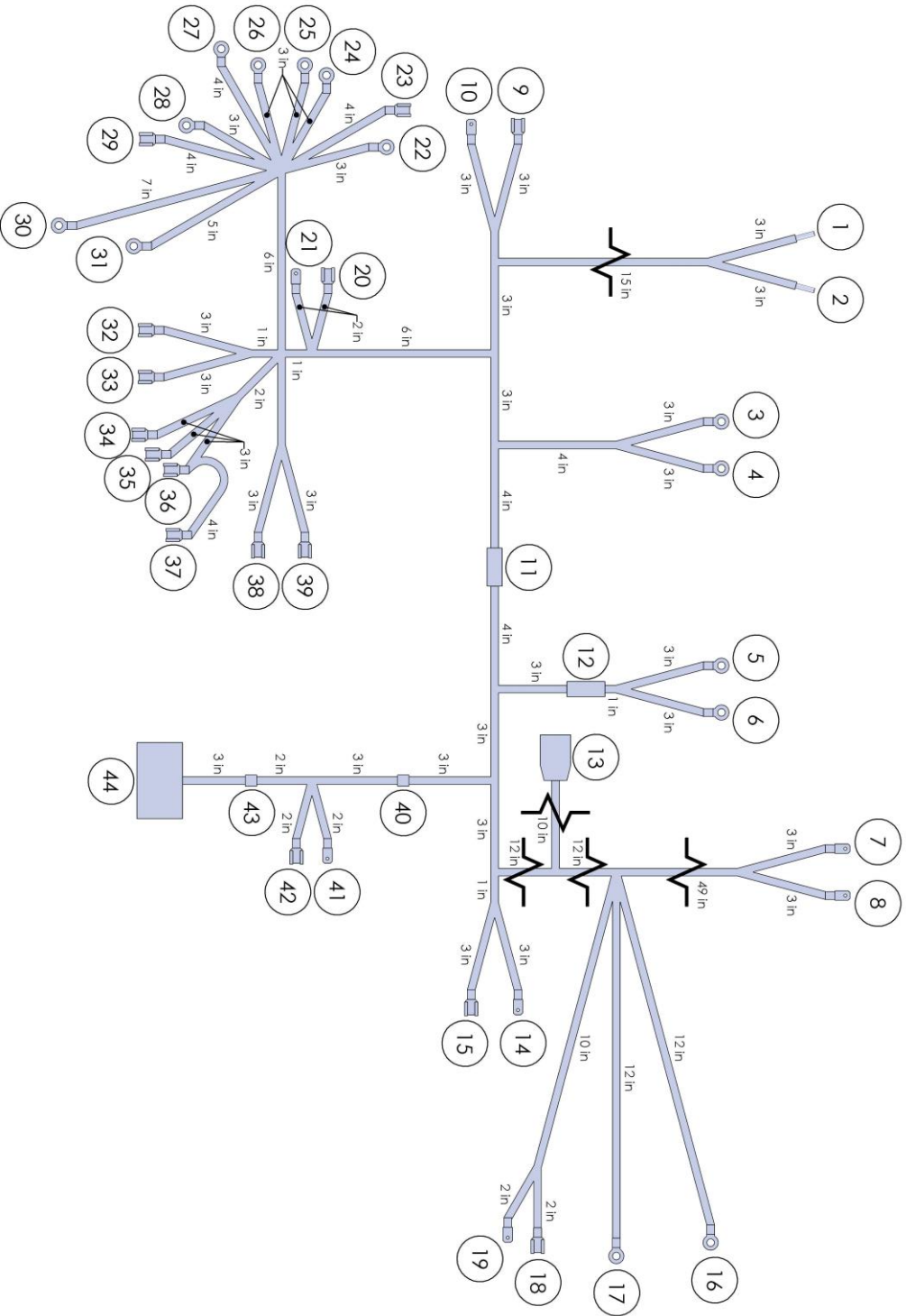

SEE ACCOMPANYING TABLE FOR TERMINAL IDENTIFICATION LABELS

BT-SB40 MAIN WIRING HARNESS

ITEM	DESCRIPTION
1	LIMIT_SW_NO1
2	LIMIT_SW_NO2
3	MAIN_BATT_NEG_1
4	MAIN_BATT_NEG_2
5	MAIN_BATT_POS_1
6	MAIN_BATT_POS_2
7	FWD (ROTATION MOTOR)
8	REV (ROTATION MOTOR)
9	L_LTS_BLK_SP
10	L_LTS_RED_SP
11	FUEL_RESERVE_FUSE
12	MAIN_FUSE
13	KEY_SW_PLUG1
14	R_LTS_RED_SP
15	R_LTS_BLK_SP
16	MAIN_GND
17	MAIN_POWER (STARTER)
18	TO_STARTER (FEMALE Q.D.)
19	TO_STARTER_SIG (MALE Q.D.)
20	LEFT_PB_RET
21	LEFT_PB_COM
22	CONTACTOR_POS1
23	CONTACTOR_T1
24	CONTACTOR_REV
25	CONTACTOR_FWD
26	CONTACTOR_POS_MAIN
27	CONTACTOR_NEG_MAIN
28	CONTACTOR_POS2
29	CONTACTOR_T2
30	FUEL_RESERVE_POS
31	FUEL_RESERVE_NEG
32	USB_POS
33	USB_NEG
34	LTS_SW_3
35	LTS_SW_6
36	LTS_SW_1
37	LTS_SW_4
38	FR_SW_1
39	FR_SW_3
40	PWR_SP1
41	RIGHT_PB_COM
42	RIGHT_PB_RET
43	PWR_SP2
44	LARGE FUSE BOX

BT-SB40 PARTS REFERENCE

MACHINE ASSEMBLY

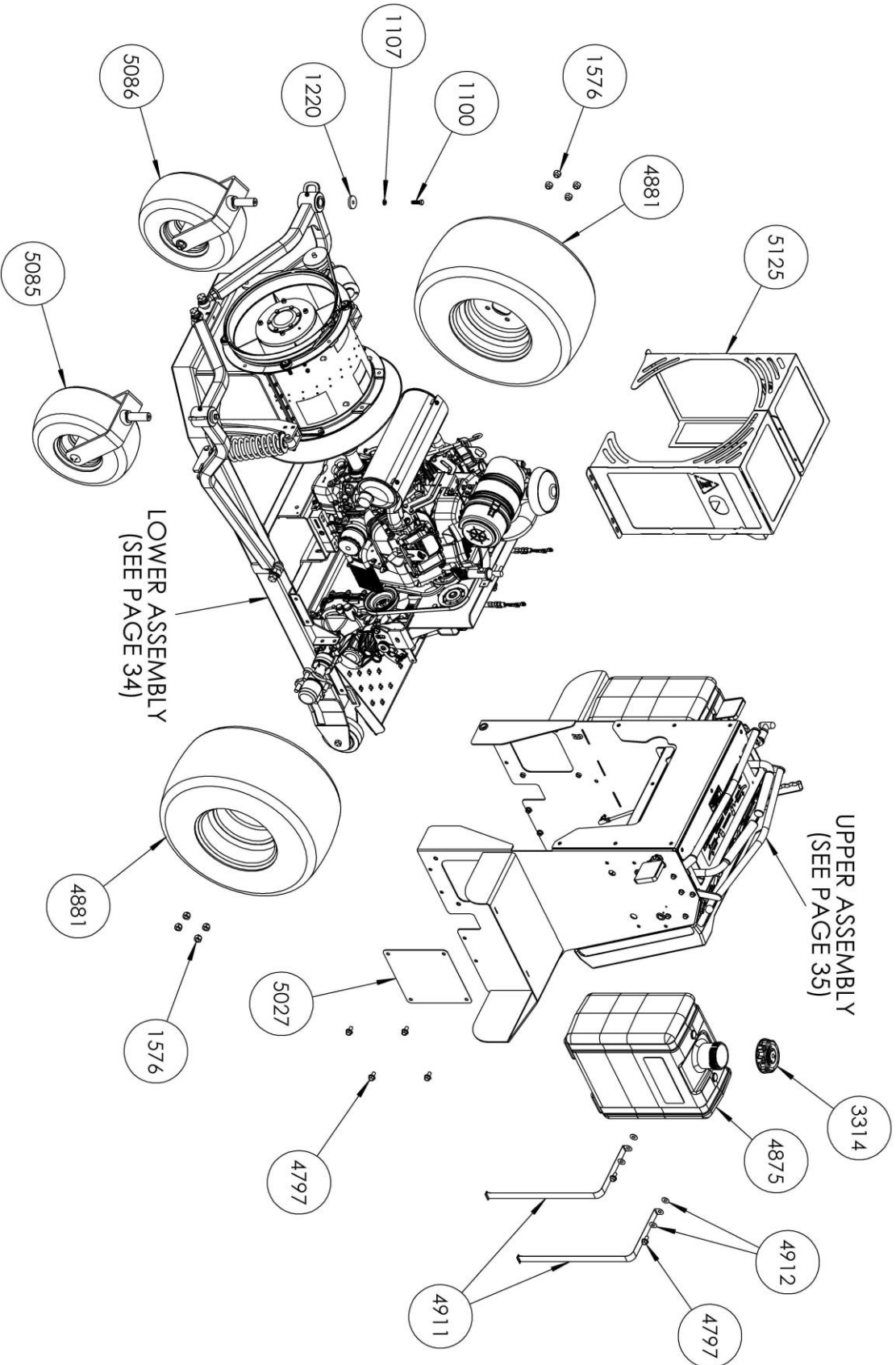

NOT ALL HARDWARE/WIRING IS SHOWN

BT-SB40 PARTS REFERENCE

LOWER ASSEMBLY

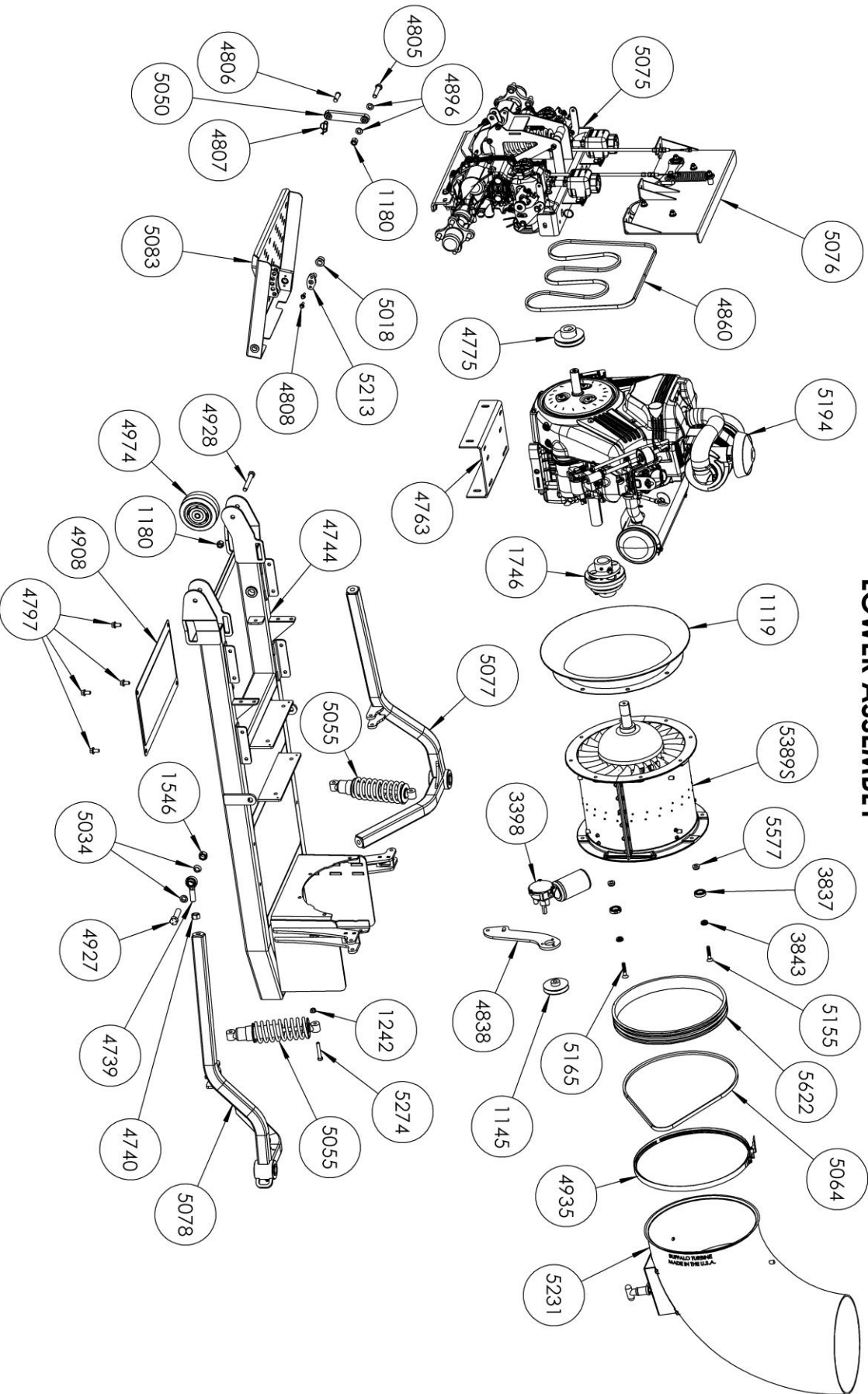

NOT ALL HARDWARE/WIRING IS SHOWN

BT-SB40 PARTS REFERENCE

TRANSAXLE SUBASSEMBLY - 5075

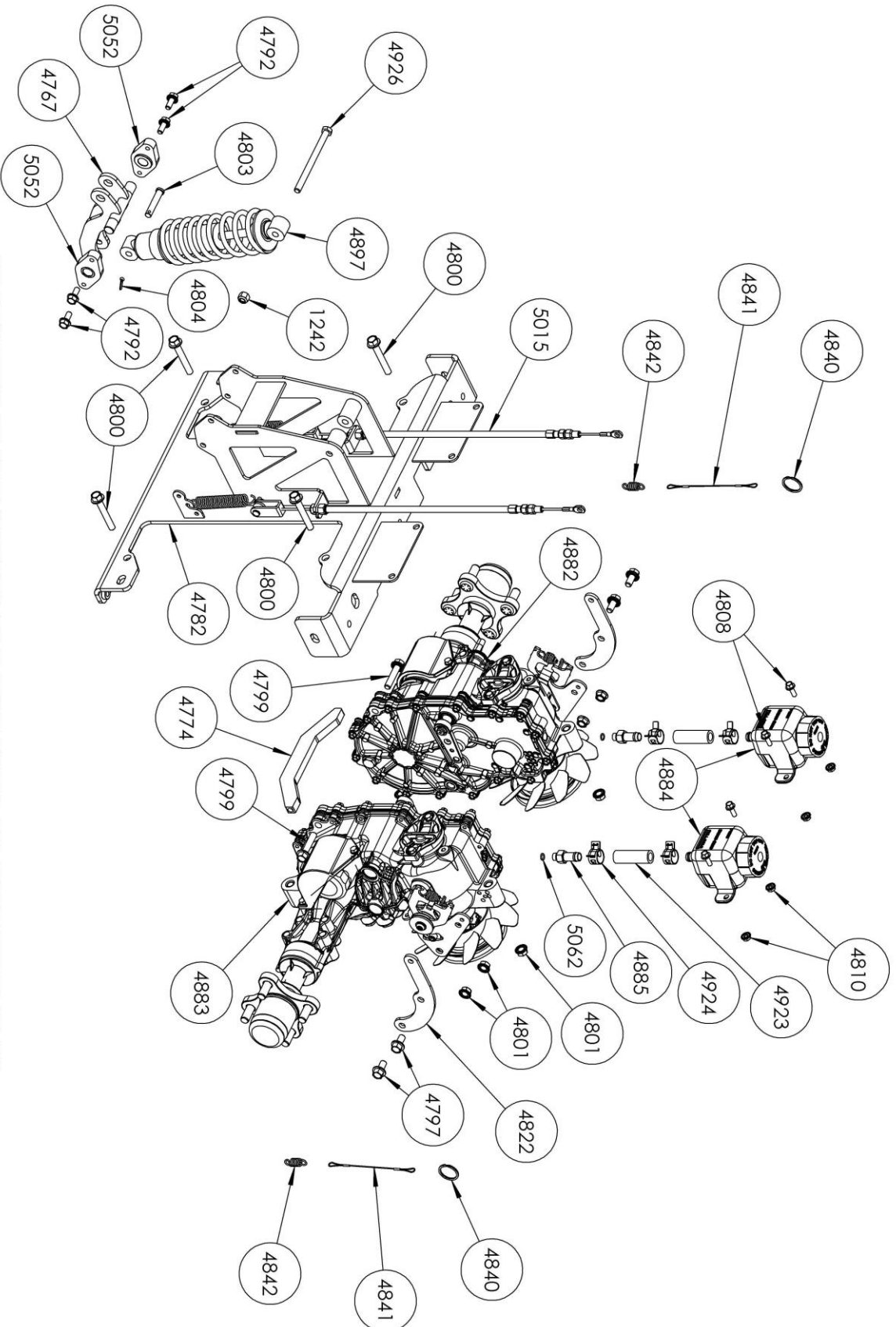

BREAKDOWN OF SUBASSEMBLY 5075 CONTINUED ON FOLLOWING PAGE

BT-SB40 PARTS REFERENCE

TRANSAXLE SUBASSEMBLY - 5075 (CONTINUED)

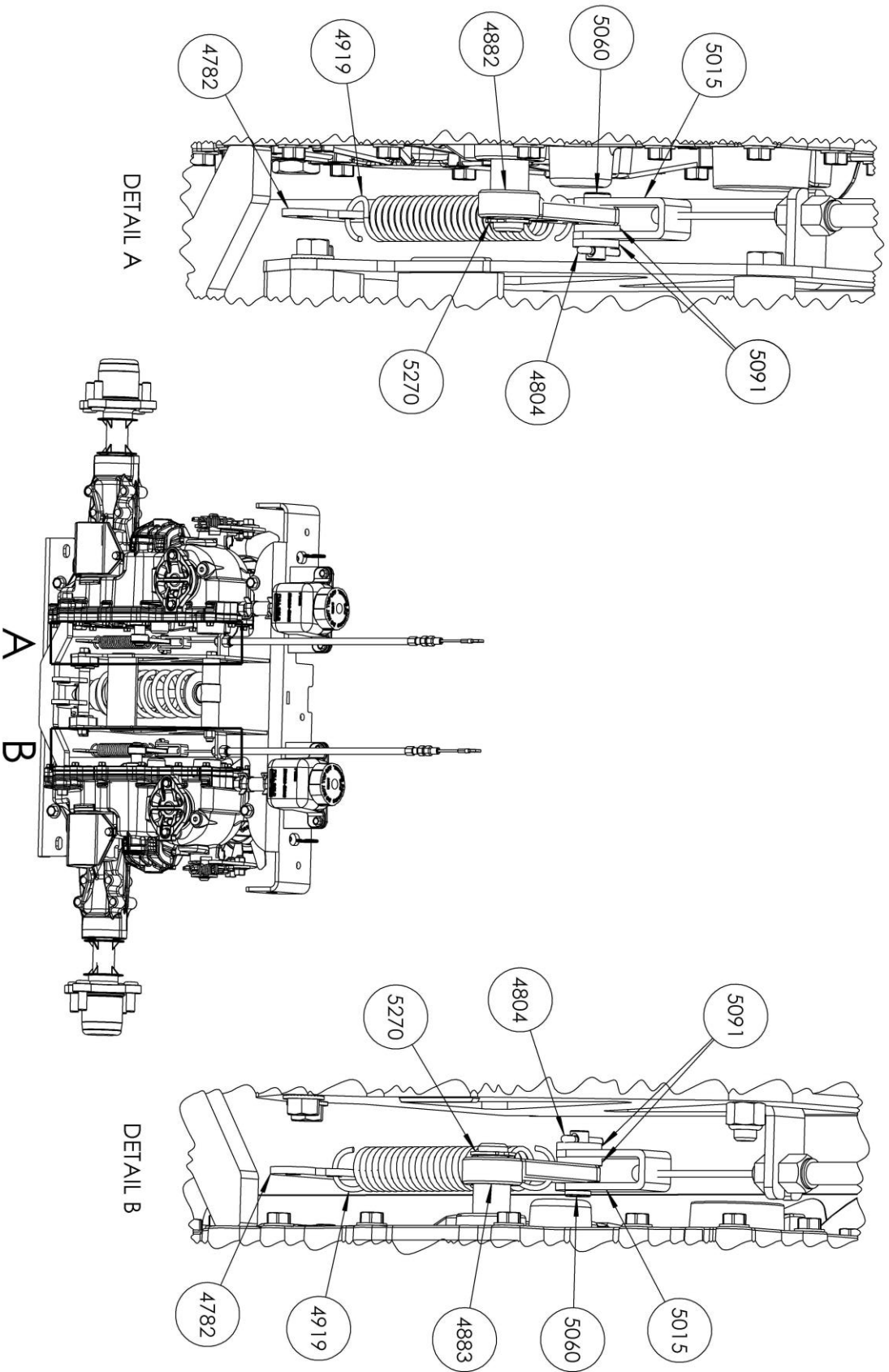

BT-SB40 PARTS REFERENCE

TENSIONER & IDLER SUBASSEMBLY - 5076

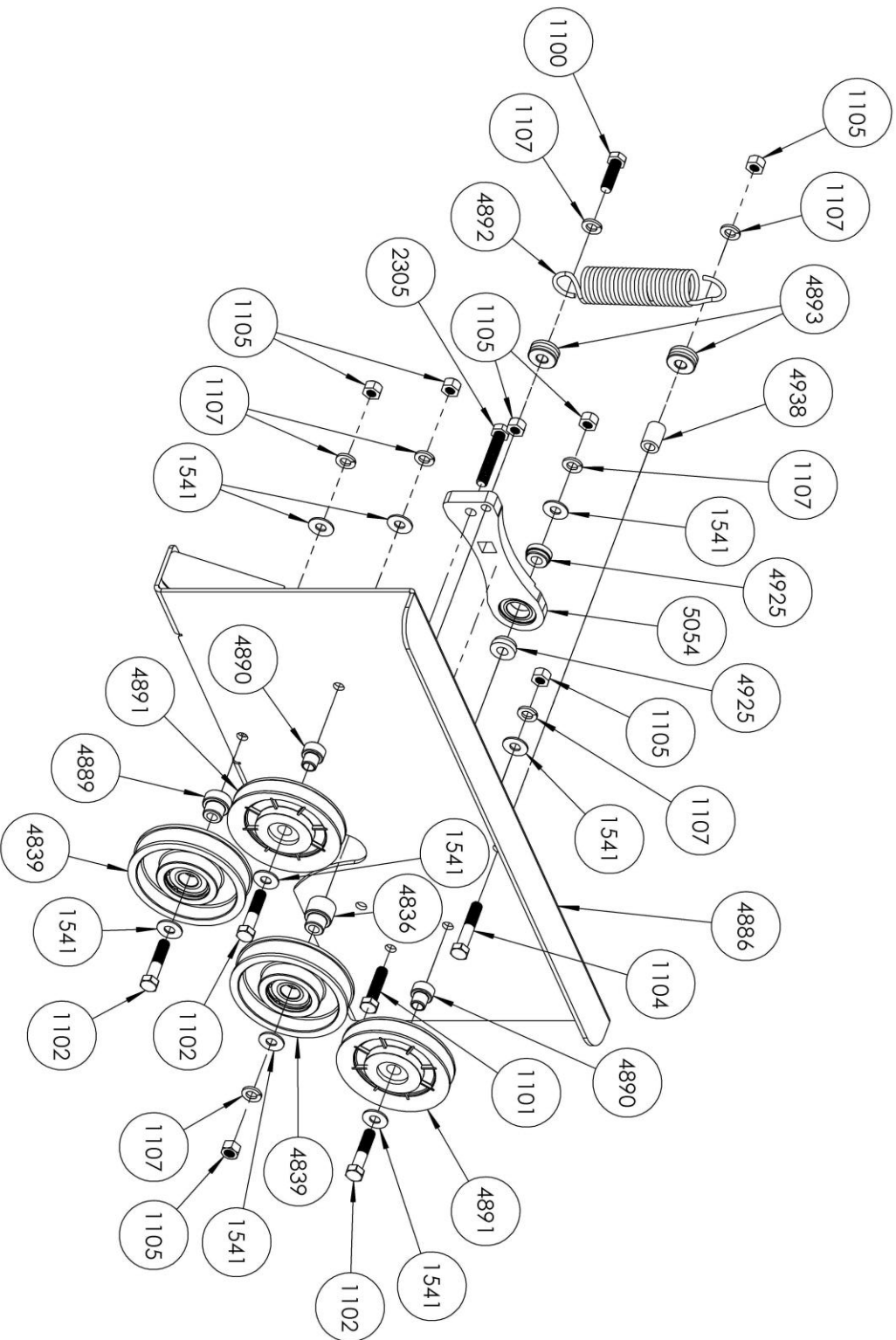

BT-SB40 PARTS REFERENCE

LED LIGHT SUBASSEMBLY - 5080

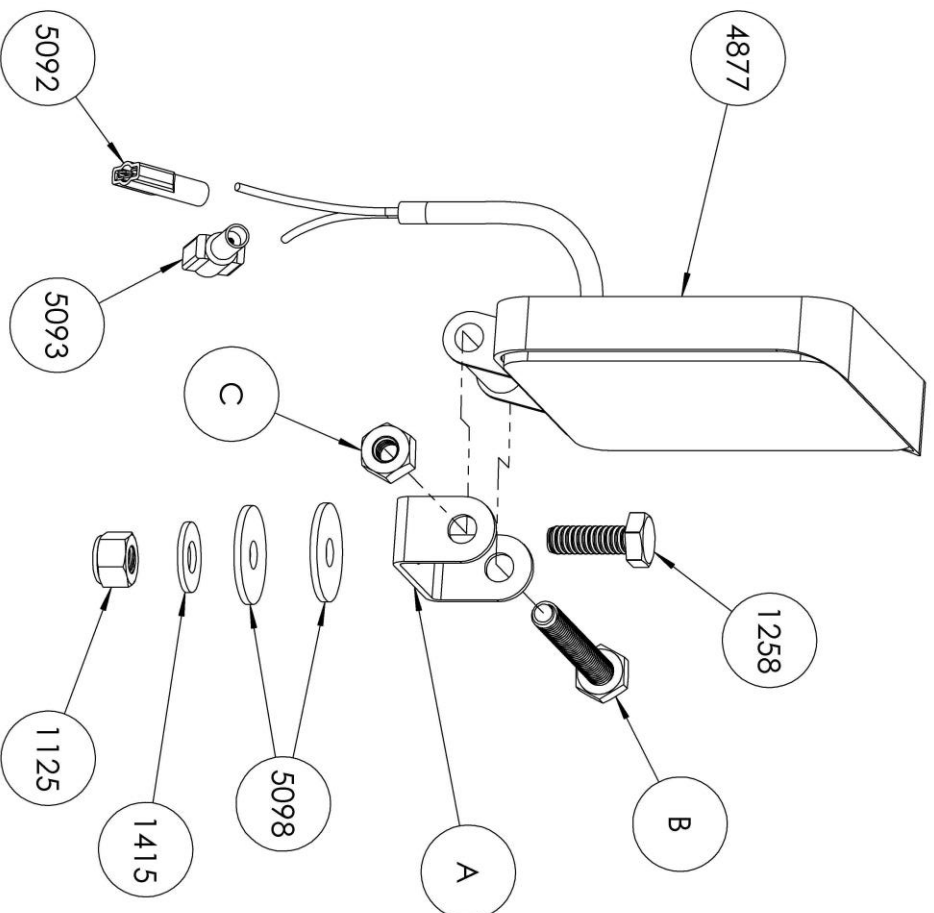

PARTS A, B, & C ARE INCLUDED WITH PART 4877

BT-SB40 PARTS REFERENCE

CONTROL PANEL SUBASSEMBLY - 5082

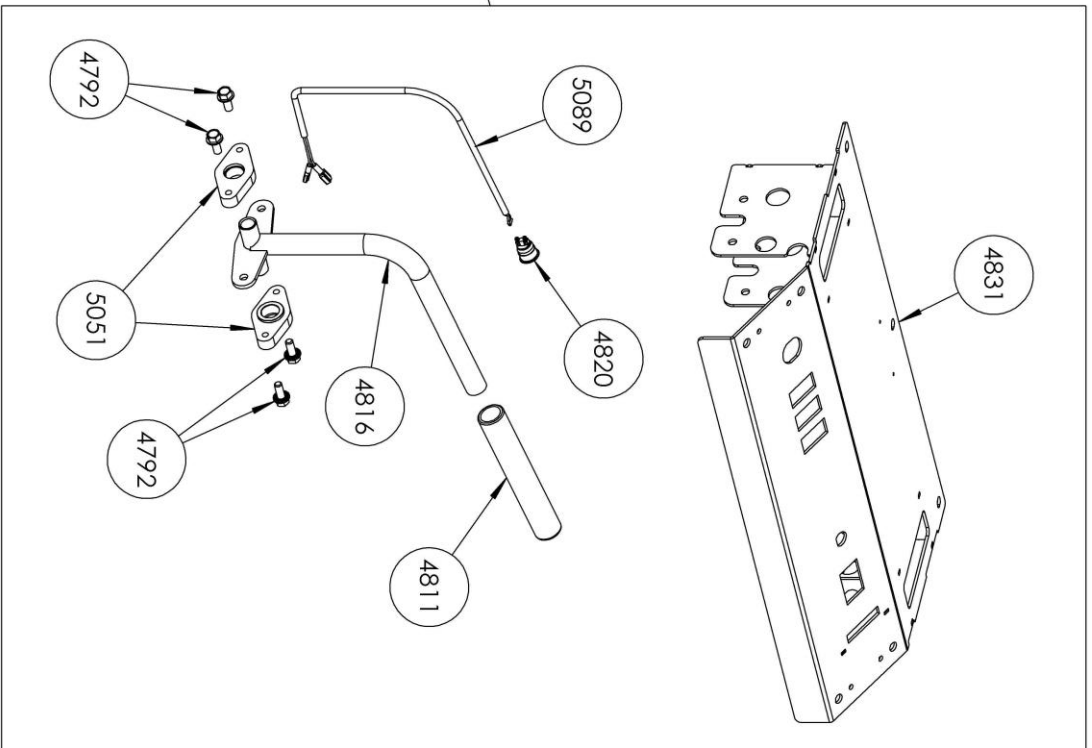
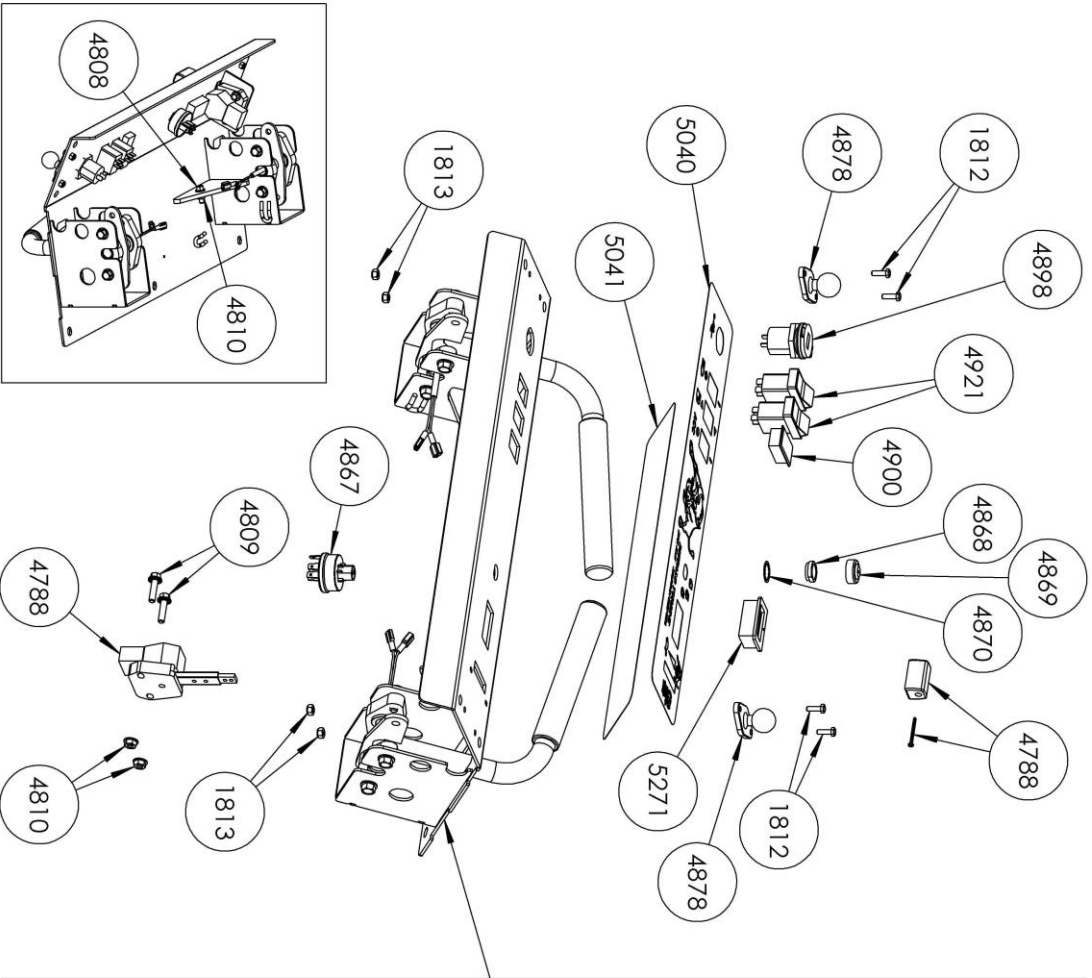

BT-SB40 PARTS REFERENCE

PLATFORM SUBASSEMBLY - 5083

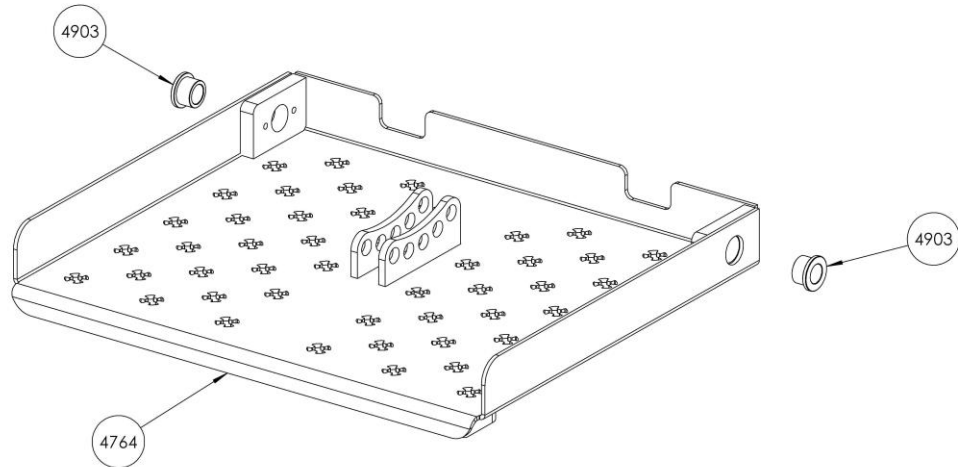

NOTE: PART 4903 IS PRESSED INTO PART 4764

BT-SB40 PARTS REFERENCE

LEANING PAD SUBASSEMBLY - 5084

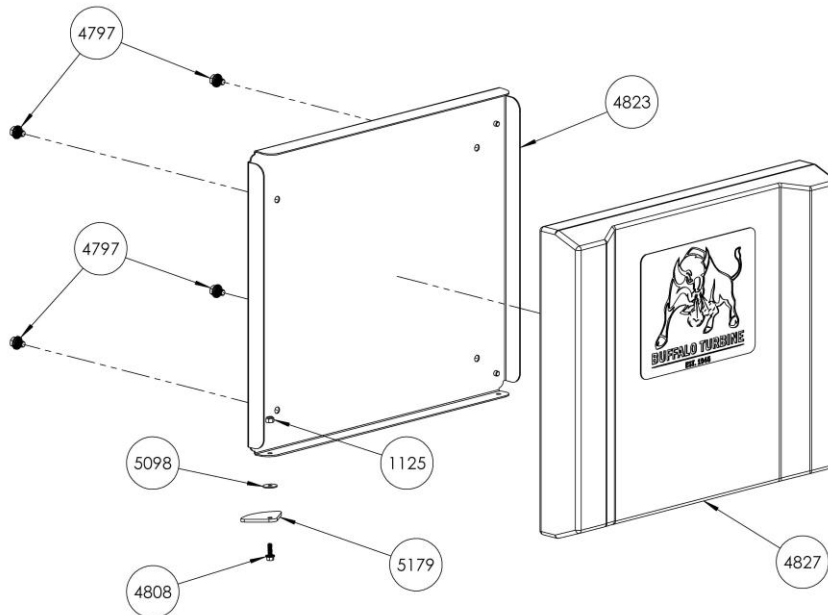

BT-SB40 PARTS REFERENCE

FRONT CONTROL ARM SUBASSEMBLIES

5077

LEFT FRONT CONTROL ARM SUBASSEMBLY

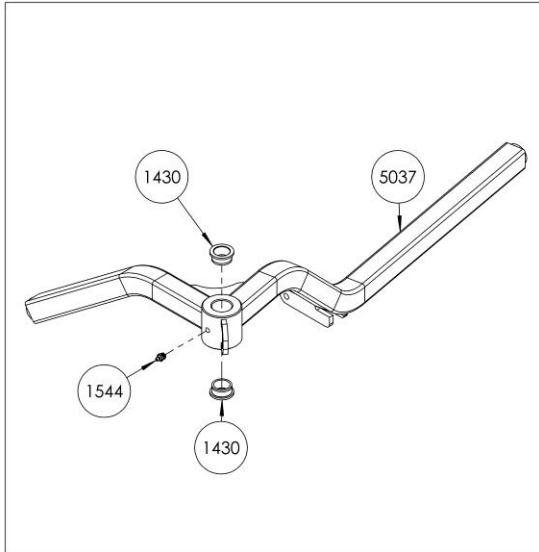

5078

RIGHT FRONT CONTROL ARM SUBASSEMBLY

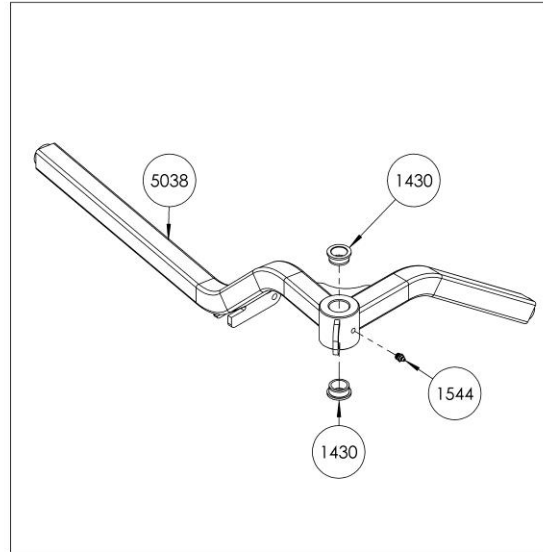

BT-SB40 PARTS REFERENCE

FRONT CASTER SUBASSEMBLIES

5085

LEFT FRONT CASTER SUBASSEMBLY

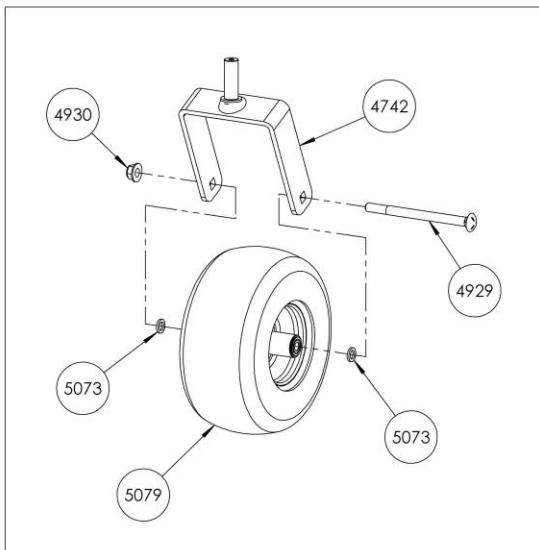

5086

RIGHT FRONT CASTER SUBASSEMBLY

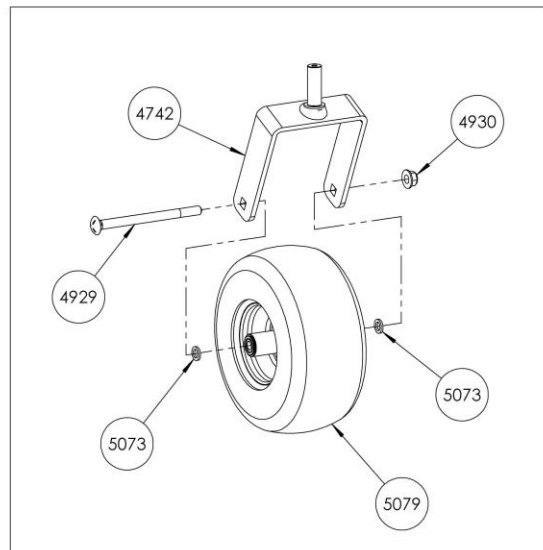

NOTE: BOLT ORIENTATION IN 5085 & 5086 IS CRITICAL TO KEEPING MACHINE UNDER 48" WIDE OVERALL

BT-SB40 PARTS REFERENCE

FRONT WHEEL SUBASSEMBLY - 5079

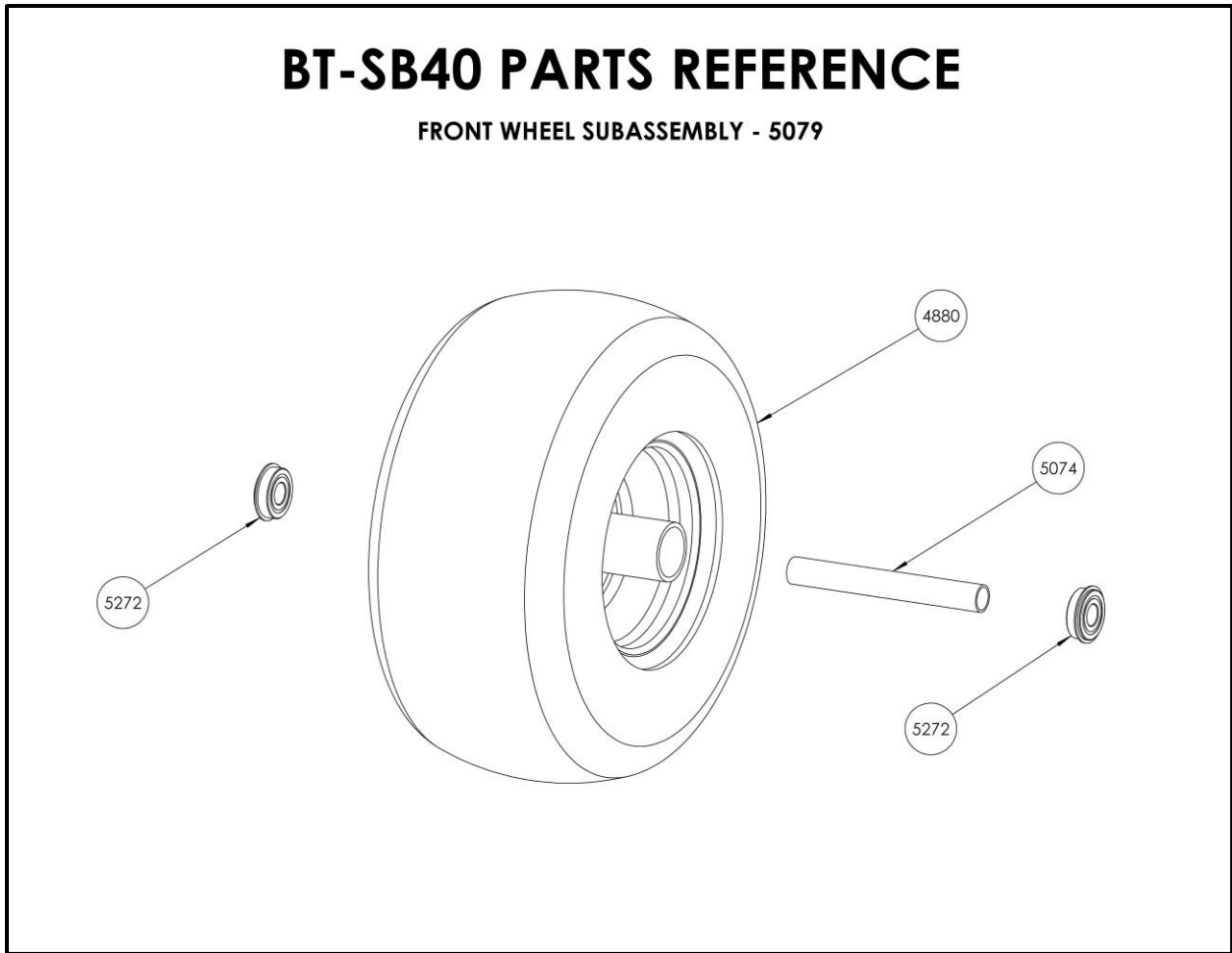

Quick Reference QR Codes

Transaxle Purge Procedure:



Transaxle Service Manual:



40HP Engine Service Manual:



Bill of Materials

PART #	DESCRIPTION	QUANTITY	REFERENCE PGS.
1100	1-1/4" 3/8-24 Hex Bolt	3	35, 40
1101	1-1/2" 3/8-24 Hex Bolt	1	40
1102	1-3/4" 3/8-24 Hex Bolt	3	40
1104	2" 3/8-24 Hex Bolt	1	40
1105	3/8-24 Hex Nut	7	40
1107	3/8 Lock Washer	9	35, 40
1108	3/8 Flat Washer	2	
1109	1/2" X 3/16 Roll Pin	4	
1112	7/16-20 Nut	4	
1113	2-1/2" 7/16-20 Bolt	4	
1114	Coupling Flange 1-1/4 Bore	1	
1115	Coupling Flange 1-7/16 Bore	1	
1119	Bellmouth	1	36
1125	1/4-20 Nyloc Nut	5	41, 43
1130	5/16-18 X 3/8 Set Screw	1	
1131	3/8" X 3/8-16 Set Screw	2	
1145	Rotation Motor Sheave	1	36
1156	Aluminum Serial Tag	1	
1158	Inches Of 1/4" Fuel Line	111	
1168	Threaded Hose Clamp	3	
1180	1/2-13 Nyloc Nut	3	36
1181	Quarts Of Oil 10W-30	2	
1182	4" X 4" BT Decal	2	
1186	Caution Decal	1	
1220	3/8 X 1-5/8 Retainer Washer	2	35
1233	America & Safety First Decal	1	
1242	3/8-16 Nyloc Nut	1	38
1256	Coupling Center	1	
1258	3/4" 1/4-20 Hex Head Bolt	2	41
1271	5/16-18 Nyloc Nut	4	37
1275	8" Black Cable Ties	17	
1415	1/4 Flat Washer	2	41
1430	Caster Bushing	4	44
1540	5/16 Lock Washer	1	37
1541	5/16 Flat Washer	13	37, 40
1544	1/8-27 Grease Fitting	2	44
1546	5/8-11 Centerlock Hex Nut	4	36
1576	1/2-20 Lug Nut	8	35
1669	1/4-20 X .055 Head Insert	4	
1746	Coupling Kit	1	36
1812	10-32 X .625 HHCS	4	42
1813	10-32 Nyloc Lock Nut	4	42
1819	12" Black Cable Ties	1	
2233	1-1/4" X 3/16 Roll Pin	1	37

2305	2-1/4" 3/8-24 Hex Bolt	1	40
2639	5/8" Bore Rubber Grommet	7	37
2869	3/8" X 7/16-20 Set Screw	4	
3007	Constant Tension Hose Clamp	5	
3062	EPA Emissions Label	1	
3067	EPA Emissions Date Label	1	
3238	1" Wide Battery Strap	1	
3314	Fuel Tank Cap	2	35
3398	Rotation Motor	1	36
3837	Elbow Base Ring Bearing	4	36
3843	Bearing Bushing	4	36
4548	Prop 65 Label, 2" X 2"	1	
4725	Combined Warning Decal	1	
4739	5/8" Heim Joint	4	36
4740	5/8-18 Hex Nut	4	36
4742	Yoke Weldment 13" Tire	2	44
4744	Frame	1	36
4763	Engine Mounting Plate	1	36
4764	Operator Platform Weldment	1	43
4767	Suspension Link Weldment	1	38
4772	Battery Tray	1	37
4774	Transaxle Spacer	1	38
4775	Single Groove Pulley	1	36
4776	Left Panel Weldment	1	37
4779	Right Panel Weldment	1	37
4782	Transaxle Mounting Weldment	1	38, 39
4788	Thumb Throttle	1	42
4790	5/16-24 Heim Joint	4	37
4791	5/16-24 Hex Nut	4	37
4792	3/4" 5/16-18 Serr. Flange Hex Bolt	18	37, 38, 42
4793	2" 5/16-18 Serr. Flange Hex Bolt	4	
4794	2-3/4" 5/16-18 Serr. Flange Hex Bolt	4	
4795	5/16-18 Serr. Flange Hex Nut	14	37
4797	3/4" 3/8-16 Serr. Flange Hex Bolt	47	35, 36, 38, 43
4798	1" 3/8-16 Serr. Flange Hex Bolt	17	
4799	1-3/4" 3/8-16 Serr. Flange Hex Bolt	2	38
4800	2-1/2" 3/8-16 Serr. Flange Hex Bolt	4	38
4801	3/8-16 Serr. Flange Hex Nut	51	38
4803	3/8" Diameter X 2" Long Pin; Zinc	1	38
4804	3/4" Long, 1/8" Dia. Cotter Pin, Zinc	3	38, 39
4805	2-1/4" 1/2-13 Hex Bolt	1	36
4806	1-1/2" 1/2 Pin	1	36
4807	2" Cotter Pin	1	36
4808	3/4" 1/4-20 Serr. Flange Hex Bolt	16	36, 38, 42, 43
4809	1" 1/4-20 Serr. Flange Hex Bolt	2	42
4810	1/4-20 Serr. Flange Hex Nut	13	38, 42
4811	Handle Bar Grip; Vinyl Black	2	42

4812	Fixed Handlebar Weldment	1	37
4816	Motion Control Weldment	2	42
4820	Push-Button Switch For Nozzle Rotation	2	42
4821	Motion Control Link	2	37
4822	Transaxle Extension Arm	2	38
4823	Leaning Pad Support Weldment	1	43
4827	Leaning Pad	1	43
4829	Front Panel Weldment	1	37
4831	Control Panel Weldment	1	42
4836	Tensioner Bushing	1	40
4838	Rotation Motor Bracket	1	36
4839	Tensioner Pulley	2	40
4840	1-1/4" Diameter Key Ring, Zinc Plated	2	38
4841	6" Long Galvanized Steel Lanyard	2	38
4842	1-1/2" Long Closed Loop Tension Spring	2	38
4860	92" Transaxle Drive Belt	1	36
4867	Ignition Switch	1	42
4868	Nut For Ignition	1	42
4869	Cap For Ignition	1	42
4870	Internal Tooth Lock Washer	1	42
4871	Starter Key	1	
4875	8 Gal. Gas Tank	2	35
4877	LED Light Sub Assembly	2	41
4878	Ram Ball Mount	2	42
4880	13 X 6.5 - 6 Smooth Tread Wheel	2	45
4881	Rear Wheel Sub Assembly	2	35
4882	LH Transaxle	1	38, 39
4883	RH Transaxle	1	38, 39
4884	Expansion Tank	2	38
4885	Adapter For Expansion Tank	2	38
4886	Idler Weldment	1	40
4889	Backside Idler Bushing	1	40
4890	V-Groove Idler Bushing	2	40
4891	4" Diameter V-Belt Idler Pulley	2	40
4892	1-1/4" OD X 5-1/2" Long Extension Spring	1	40
4893	Spring Bushing	2	40
4896	1/2" Delrin Washer	2	36
4897	Shock/Spring Sub Assembly	1	38
4898	12V USB And Auxiliary Power Outlet	1	42
4899	Fuel Shutoff And Switchover Valve	1	37
4900	Panel Plug; 1.720" X 0.9655"	1	42
4903	5/8" ID, 7/8" OD, 5/8" Long Flanged Bearing	2	43
4905	Adjustable Handlebar Weldment	1	37
4907	Spring Controlled Pin	1	37
4908	Bottom Guard	1	36
4911	Fuel Tank Strap	4	35
4912	3/8" Washer	8	35

4913	9/16 OD Bronze Bushing	4	37
4914	9/16" Delrin Washer	8	37
4917	1" 5/16-18 Serr. Flange Hex Bolt	6	37
4918	Parking Brake Safety Switch	1	37
4919	Lower Parking Brake Spring	2	39
4920	Upper Parking Brake Spring	2	37
4921	Rocker Switch (4 Terminal)	2	42
4922	Reversing Polarity Contactor	1	37
4923	Inches of 1/2" ID, Hydraulic Hose	5.25	38
4924	Constant Tension Hose Clamp	4	38
4925	Tensioner Arm Spacer	2	40
4926	3/8-16 X 5" Long HHCS	1	38
4927	2-1/2" 5/8-11 Hex Bolt	4	36
4928	3-3/4" 1/2-13 Hex Bolt	2	36
4929	9" 5/8-11 Long Carriage Bolt	2	44
4930	5/8-11 Flanged Nyloc Nuts	2	44
4935	Nozzle Clamp Band	1	36
4938	7/8" Long Aluminum Spacer	1	40
4972	350CCA Battery	1	37
4974	Curb Protector Wheel	2	36
4989	1-1/4" 5/16-18 Serr. Flange Hex Bolt	1	37
5006	5/16-24 Nyloc Nut	4	37
5009	Parking Brake Lever	1	37
5010	Hand Grip	1	37
5011	Parking Brake Shaft	1	37
5014	Parking Brake Link	2	37
5015	Parking Brake Cable Sub Assembly	2	38, 39
5016	Retention Collar	1	37
5017	Bolt-On Cable Bracket	2	37
5018	3/4" Long 7/8" OD Flanged Bronze Bearing	2	36
5019	5/16" Delrin Washer	4	
5027	Side Access Panel	2	35
5034	Heim Joint Bushing	8	36
5037	Left Control Arm Weldment	1	44
5038	Right Control Arm Weldment	1	44
5040	Control Panel Overlay	1	42
5041	Operator Tower Overlay	1	42
5046	Shortened Plastic Nozzle	1	36
5050	Platform Suspension Link	1	36
5051	Motion Control Bearing Sub Assembly	4	42
5052	Push Rod Pivot Bearing	3	37, 38
5053	Parking Brake Bearing	1	37
5054	Tensioner Arm Sub Assembly	1	40
5055	Front Shock/Spring	2	36
5056	1/8" Steel Rivets	2	
5057	1/4" X 1/4" 3/16 Barbed Plastic Tee	1	
5060	5/16" Dia. Clevis Pin, 3/4" Usable Length	2	39

5062	O-Ring For Transaxle Adapter	2	38
5063	19" X 5.5" "Buffalo Turbine" Decal	1	
5064	AX52 V-Belt	1	36
5073	Wheel/Yoke Spacer	4	44
5074	Wheel Bearing Spacer	2	45
5075	Transaxle Sub Assembly	1	36
5076	Tensioner/Idler Sub Assembly	1	36
5077	Left Control Arm	1	36
5078	Right Control Arm	1	36
5079	Front Wheel Sub Assembly	2	44
5080	Led Light Sub Assembly	2	37
5082	Control Panel Sub Assembly	1	37
5083	Operator Platform	1	36
5084	Leaning Pad Sub Assembly	1	37
5085	Left Front Wheel Sub Assembly	1	35
5086	Right Front Wheel Sub Assembly	1	35
5087	Drive Belt Layout Decal	1	
5088	Inches Of Conspicuity Tape	16	
5089	Motion Control Harness	2	42
5091	1/8" Thick Spacer	4	39
5092	22/18 AWG Female Quick Disconnect	1	41
5093	22/18 AWG Male Quick Disconnect	1	41
5094	1" 5/16-18 Hex Head Bolt	1	37
5095	Main Wire Harness	1	
5098	1/4" Plastic Washer	9	43
5100	Modified Engine Harness	1	
5125	Guard Kit	1	35
5155	1-1/2" 3/8-16 Flat SHCS	2	36
5164	1-1/4" 3/8-16 Serr. Flange Hex Bolt	6	
5165	1-3/4" 3/8-16 Flat SHCS	2	36
5179	Leaning Pad Retainer	1	43
5193	3/4" 1/4-28 Serr. Flange Hex Bolt	3	
5194	40HP Engine Kit	1	36
5213	Hinge Pin Sub Assembly	2	36
5231	14" Butterfly Valve Nozzle Assembly	1	36
5270	E-Clip for Transaxle Parking Brake Lever	2	39
5271	Hour Meter	1	42
5272	Bearing With External Snap Ring	4	45
5274	2-1/4" 3/8-16 Serr. Flanged Hex Bolt	4	36
5577	Large Bearing Spacer	4	36
5622	Thick Flange Base Ring	1	36
5389S	Right Hand Blower Sub Assembly, Not Nipped	1	36
TT-593C	Strain Relief Sleeve	1	

Troubleshooting Guide

Symptom	Causes	Actions
Engine Will Not Start/Turn Over	Out of fuel.	Add fuel to fuel tanks.
	Gas is old or stale.	Replace fuel in fuel tanks.
	Water in fuel.	
	Blown fuse.	Replace blown fuse. See <i>Fuse Box Location & In-Line Fuse Identification</i> .
	Loose or corroded battery connections.	Clean and tighten battery terminals. See <i>Battery Maintenance</i> .
	Battery dead.	Charge or replace battery. See <i>Battery Maintenance</i> .
	Ignition relay faulty.	Replace ignition relay. See <i>Fuse Box Location & In-Line Fuse Identification</i> .
	Key switch faulty.	Replace key switch. Contact Buffalo Turbine Service Department.
	Wiring issues.	Check wiring and repair any issues. Tighten loose connections.
	Spark plug(s) faulty, fouled, or incorrectly gapped.	Clean, gap or replace spark plugs. ¹
	Parking brake is not engaged.	Engage parking brake.
	Parking brake switch faulty.	Replace parking brake switch. Contact Buffalo Turbine Service Department.
Engine Runs Rough or Stalls	Air filter is dirty or clogged.	Clean or replace air filter. ¹
	Out of fuel.	Add fuel to fuel tanks.
	Gas is old or stale.	Replace fuel in fuel tanks.
	Water in fuel.	
	Fuel filter is plugged.	Replace fuel filter. See <i>Changing the Fuel Filter</i> .
	Spark plug(s) faulty, fouled, or incorrectly gapped.	Clean, gap or replace spark plugs. ¹
Engine Knocks	Using low octane fuel (below 87 AKI/91 RON).	Replace fuel with recommended fuel. ¹
	Gas is old or stale.	Replace fuel in fuel tanks.
	Engine oil under filled.	Add oil to engine.
	Using wrong grade oil.	Replace oil with recommended oil. ¹
	Spark plug(s) faulty, fouled, or incorrectly gapped.	Clean, gap or replace spark plugs. ¹
	Carbon deposits in combustion chamber.	Use a suitable fuel additive.
Engine Exhaust is Black	Air filter is dirty or clogged.	Clean or replace air filter. ¹ <i>Changing the Air Filter</i> .
Excessive Oil Consumption	Engine is overheating.	Clean oil cooler fins, flywheel area, air intake area, and around the muffler. ¹
	Using wrong grade oil.	Replace oil with recommended oil. ¹
	Engine oil over filled.	Drain excess engine oil.

Excessive Fuel Consumption	Air filter is dirty or clogged.	Clean or replace air filter. ¹ <i>Changing the Air Filter.</i>
	Underinflated tires.	Adjust tire pressure. See <i>Machine Specifications.</i>
Throttle Response is Delayed or Erratic	Faulty throttle control.	Replace throttle control. Contact Buffalo Turbine Service Department.
	Wiring issues.	Check wiring and repair any issues. Tighten loose connections.
Battery Not Charging	Loose or corroded battery connections.	Clean and tighten battery terminals. See <i>Battery Maintenance.</i>
	Blown fuse.	Replace blown fuse. See <i>Fuse Box Location & In-Line Fuse Identification.</i>
Engine Runs but Machine Will Not Drive	Drive belt is broken.	Replace drive belt. See <i>Changing the Drive Belt.</i>
	Drive belt is slipping.	Refer to <i>Drive Belt Slips</i> below.
	Transaxles' bypass valves are engaged.	Disengage transaxle bypass valves.
	Transaxle oil under filled.	Add oil to transaxle, only when cool.
	Transaxles' filters are clogged.	Replace the transaxle filters. See <i>Changing the Transaxles' Oil and Filters.</i>
	Motion control arms are loose or disconnected.	Tighten or reconnect motion control arms. See <i>Adjusting the Motion Control Arms.</i>
Drive Belt Slips	Belt worn or stretched.	Replace drive belt. See <i>Changing the Drive Belt.</i>
	Pulleys or belt path obstructed.	Clear any obstructions around the pulley plate.
	Pulley or belt contaminated with grease or oil.	Clean pulley and belt, or replace belt if needed. See <i>Changing the Drive Belt</i>
Parking Brake Will Not Hold	Parking brake is not engaged.	Engage parking brake.
	Parking brake linkage is loose or disconnected.	Tighten or reconnect parking brake linkage. See <i>Adjusting/Testing the Parking Brake.</i>
Machine Steers or Handles Poorly	Motion control arms are loose or disconnected.	Tighten or reconnect motion control arms. See <i>Adjusting the Motion Control Arms.</i>
	Incorrect tire pressure.	Adjust tire pressure. See <i>Machine Specifications.</i>
Excessive Machine Vibration	Blower is out of balance.	Check blower for damage, cracks, broken or bent blades. Contact Buffalo Turbine Service Department.
	Excessive dirt or debris on rotating components.	Free rotation components of dirt or debris.
Nozzle Does Not Rotate	Nozzle rotation button faulty.	Replace nozzle rotation button. Contact Buffalo Turbine Service Department.
	Nozzle rotation motor faulty.	Replace the nozzle rotation motor. Contact Buffalo Turbine Service Department.
	Nozzle rotation belt worn or stretched.	Replace nozzle rotation belt. Contact Buffalo Turbine Service Department.

Refer to the Engine Operator's Manual. ¹



OPTIONS

180 Zoar Valley Road
Springville, NY 14141

NOZZLES +

ALUMINUM NOZZLES



Aerospace polymer nozzle w\ butterfly valve assembly - Part# 5231

Quick Connect Clamp Band - Part# 4935

Quickly remove or add nozzle with the barrel style clamp band.



Optional:
12" Extension - Part# 1468
20" Extension - Part# 1845

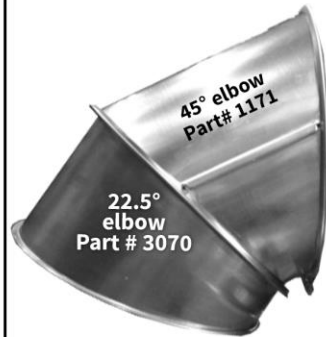

22.5° elbow
Part # 3070

45° elbow
Part# 1171

*Call sales and service to request custom nozzle configuration.

Optional aluminum nozzles **will not** connect to the standard Aerospace Polymer Nozzle (Part# 2851).

10" Round Nozzle - Part# 1417
12" Round Nozzle - Part# 1172
Improves air velocity with lower horsepower and hydraulic blower units



10" Rectangular Nozzle - Part# 1469
19" Rectangular Nozzle - Part# 1425
5.5"x15" opening - extra length/more concentrated air flow. Uses - heavy wet debris, plugs, top dressing. **No ground clearance** in the vertical down position.



Fishtail Nozzle - Part# 1743
5"x30" (wide angle) opening. Distributes a large volume of air at a lower velocity over a wide area. Easily converts blower into a "Greens Fan". Adaptable to all models. Not as effective at moving debris.



CLAMP BAND W/ BOLT & NUT

Part# 1173



WARNING:
Cancer & Reproductive Harm -
www.P65Warnings.ca.gov

BUFFALO TURBINE PRODUCTS

Cyclone eKB



Cyclone 8000 (& 8000 EFI)



Cyclone KB7



Cyclone MEGA



The Original & Most Powerful Turbine Debris Blowers
since 1945



BLITZ (& BLITZ MEGA)



Cyclone SQUARED



Cyclone Hydraulic (& Hydraulic MEGA)



Cyclone PTO (& PTO MEGA)

Visit BuffaloTurbine.com for more product info