

BUFFALO TURBINE

180 Zoar Valley Road
Springville, NY 14141

TEL: 716 592 2700 FAX: 716 592 2460

EMAIL: info@buffaloturbine.com

WEBSITE: www.buffaloturbine.com

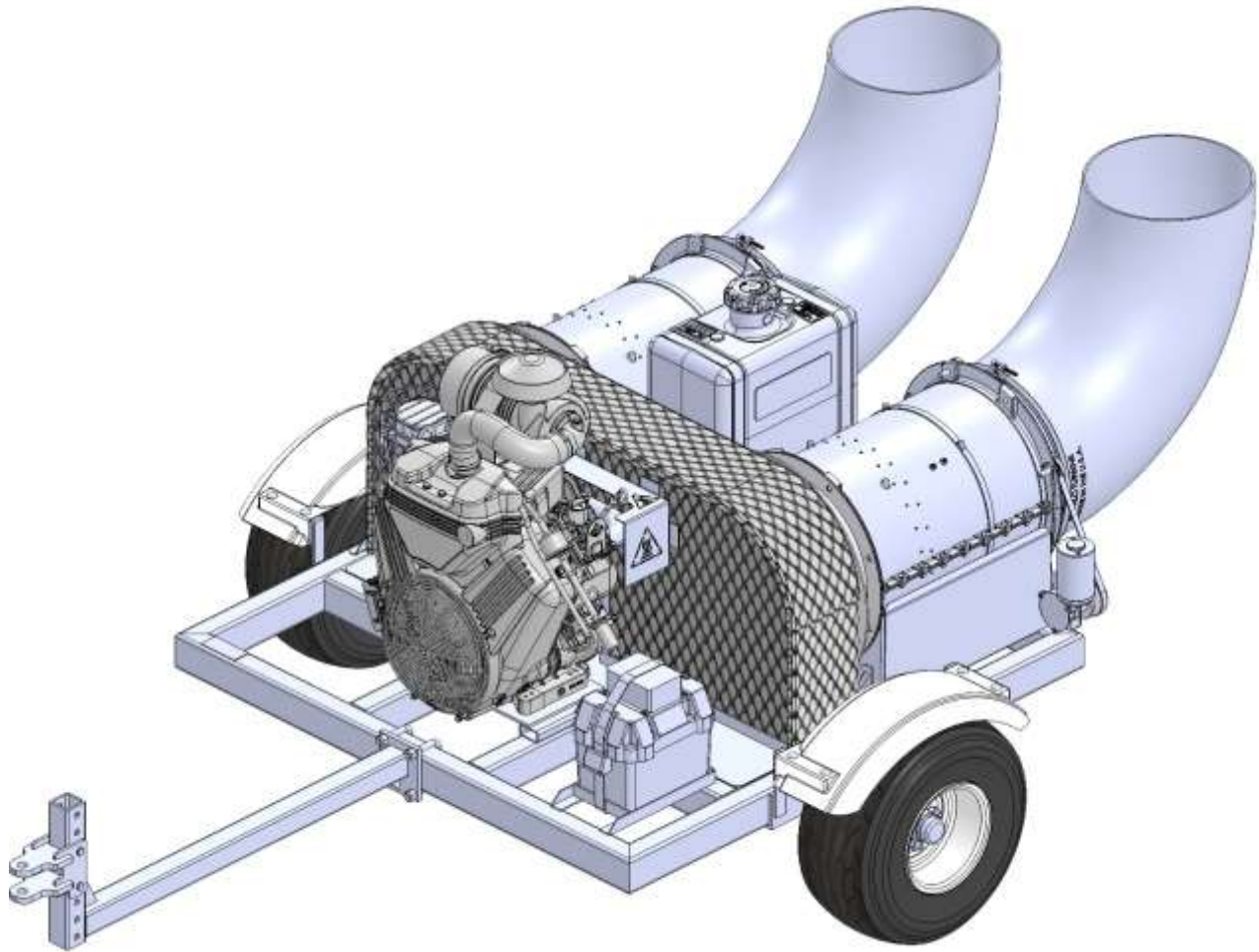

BUFFALO TURBINE'S BT-CKB4SQ ORIGINAL INSTRUCTIONS AND PARTS MANUAL

02/26 -BT MAN

TABLE OF CONTENTS

Ref. Number	Description	Page Number
1.0	Introduction	2
2.0	Safety	3
2.1	Safety Decals	4
2.2	General Safety	4
2.3	Operating Safety	4
2.4	Maintenance Safety	4
2.5	Transport Safety	5
2.6	Storage Safety	5
2.7	Sign-off Form	5
3.0	Warranty Information	6
3.1	Warranty Registration Form	7
4.0	Operations	8
4.1	To the new operator or owner	8
4.2	Break-in	8
4.3	Pre-Operation Checks	8
4.4	Model BT-CKB4SQ Assembly Instructions	9
4.5	Field Operation	10
4.6	Operating RPM	10
4.7	Storage	10
5.0	Machine Specification	10
6.0	Maintenance	11
6.1	Maintenance Safety	11
6.2	Fluids	11
6.3	Greasing Interval	11
6.4	Belt maintenance	12
6.5	Service Checklist	13
	Exploded Parts Diagram (After Serial # 38637)	14
	BT-CKB4SQ Parts Sub-Assemblies	15
	Bill of Materials for BT-CKB4SQ	16-17
7.0	Troubleshooting	18
	BT-CKB4SQ Wireless Remote System Manual	19
	Wireless system warranty information	20
	Wireless Remote System Diagnostic Tests	21-24
	Nozzle Options	25
	Buffalo Turbine Additional Products	26

1.0 INTRODUCTION

Congratulations on your choice of a Buffalo Turbine Debris Blower. This equipment has been designed and manufactured to meet the needs of the Turf Care Industry.

Safe, efficient and trouble-free operation of your Buffalo Turbine Blower requires that you and anyone else, who will be operating or maintaining the Blower, read and understand all of the safety, operation, maintenance and troubleshooting information contained within this Operator's manual.

This Manual covers the BT-CKB4SQ Turbine Blower.

Keep this manual handy for frequent reference and to pass on to new operators or owners. Call your Buffalo Turbine dealer or distributor if you need assistance, information, or additional copies of the manuals.

SERIAL NUMBER LOCATION

Always give your dealer the serial number of your Debris Blower when ordering parts or requesting service or other information.

The serial number plate(s) is located where indicated in the pictures below. Please document the number in the space provided for easy reference.

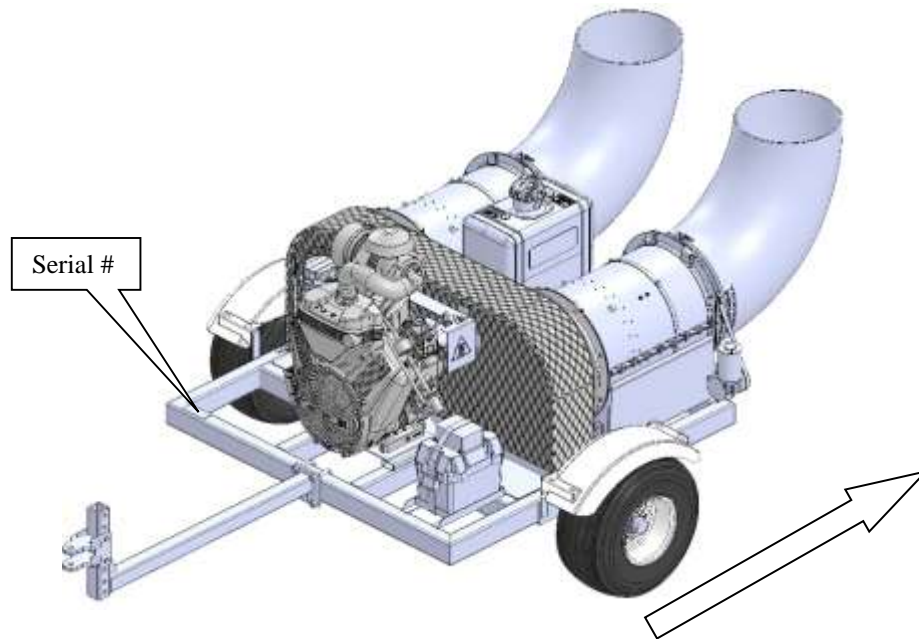

OPERATOR ORIENTATION – The directions left, right, front and rear, as mentioned throughout the manual, are as seen from the driver's seat and facing in the direction of travel.

MODEL BT-CKB4SQ RIGHT FRONT TOP SURFACE OF FRAME

Serial Number: _____

2.0 SAFETY

YOU are responsible for the **SAFE** operation and maintenance of your Buffalo Turbine Debris Blower. **YOU** must ensure that you and anyone else, who is going to operate, maintain or work around the Buffalo Turbine Blower be familiar with the operating and maintenance procedures and related **SAFETY** information contained in this manual. This manual will take you step-by-step through your working day and alerts you to all good safety practice while operating the Blower.

Remember **YOU** are the key to safety. Good safety practices not only protect you but also the people around you. Make these practices a working part of your safety program. Be certain that **EVERYONE** operating this machine is familiar with the procedures recommended and follows safety precautions. Remember most accidents can be prevented. Do not risk injury or death by ignoring good safety practices.

- Blower owners must give operating instructions to operators or employees before allowing them to operate the Blower, and at least annually thereafter.
- The most important safety device on this equipment is a **SAFE** operator. It is the operator's responsibility to read and understand **ALL** Safety and Operating instructions in the manual and to follow these. All accidents can be avoided.
- A person who has not read and understood all operating instructions is not qualified to operate the machine. An untrained operator exposes themselves and bystanders to possible serious injury or death.
- Do not modify the equipment in any way. Unauthorized modification may impair the function and/or safety which could affect the life of the equipment.
- Think **SAFETY!** Work **SAFELY!**

This Safety Alert symbol means **ATTENTION! BECOME ALERT! YOUR SAFETY IS INVOLVED!**

The Safety Alert symbol identifies important safety messages on the Buffalo Turbine Blower and in the manual. When you see this symbol, be alert to the possibility of personal injury or death. Follow the instructions in the safety message.

Why is **SAFETY** important to you?



**3 Big Reasons: Accidents Disable and Kill
Accidents Cost
Accidents Can Be Avoided**

SIGNAL WORDS: Note the use of the signal words **DANGER**, **WARNING** and **CAUTION** with the safety messages. The appropriate signal word for each message has been selected using the following guidelines

1. **DANGER** –injury or death if the proper precautions are not taken.
2. **WARNING** -- A specific hazard or unsafe practice that **COULD** result in severe personal injury or death if proper precautions are not taken.
3. **CAUTION** – Unsafe practices that **COULD** result in personal injury if proper practices are not taken, or as a reminder of good safety.

The Safety Alert symbol identifies important safety messages on the Buffalo Turbine Blower and in the manual. When you see this symbol, be alert to the possibility of personal injury or death. Follow the instructions in the safety message.

2.1 SAFETY DECALS

The types of decals on the blower unit are shown below. Good safety requires that you familiarize yourself with the various Safety Decals, the type of warning and the area, or particular function related to that area that requires your **SAFETY AWARENESS.* THINK SAFETY! WORK SAFELY!**

!ATTENTION!

1. **KEEP HANDS, FEET AND CLOTHING AWAY FROM POWER DRIVEN PARTS.**
2. **STOP ENGINE AND REMOVE KEY BEFORE LEAVING OPERATOR'S POSITION.**
3. **MACHINE MUST COME TO A COMPLETE STOP BEFORE ANY MAINTENANCE, TO INCLUDE ADJUSTING, LUBRICATING OR CLEANING, IS PERFORMED.**
4. **KEEP PEOPLE AND PETS AT SAFE DISTANCE FROM MACHINE.**
5. **KEEP ALL GUARDS AND SHIELDS IN PLACE.**

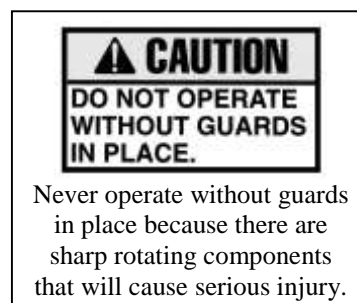
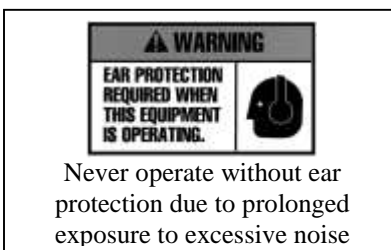
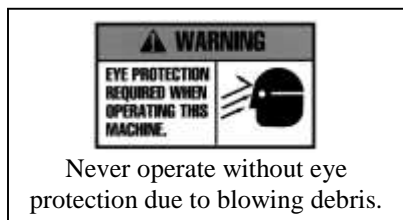

REMEMBER – If safety decals have been damaged, removed, become illegible or parts replaced without decals, new decals must be applied. New decals are available from your authorized dealer.

2.2 GENERAL SAFETY

1. Read and understand the Operator's Manual and all safety signs before operating, maintaining, and adjusting.
2. Provide a first-aid kit for use in case of an accident. Store in a highly visible place.
3. Provide a fire extinguisher for use in case of an accident. Store in a highly visible place.
4. Wear appropriate protective gear. This list includes but is not limited to:
 - A hard hat
 - Protective shoes with slip resistant soles
 - Protective glasses or goggles
 - Heavy gloves
 - Wet weather gear
 - Hearing protection
5. Do not operate without guards or shields properly installed.
6. Do not allow riders.
7. **Wear appropriate ear protection for prolonged exposure to excessive noise.**
8. **(All Models) Set Blower on the ground, stop engine, set park brake, remove ignition key and wait for all moving parts to stop before dismounting to service or adjust.**
9. Clear the area of people, especially small children, before starting the unit.
10. Review all safety related items annually with all personnel who will be operating or maintaining the Blower.
11. Keep hands, feet, hair and clothing away from moving parts. Operate equipment only while seated in the operator's seat.

2.3 OPERATING SAFETY

1. Read and understand the Operator's Manual and all safety signs before operating, servicing or adjusting.
2. Before servicing or repairing, **Set blower on the ground, stop engine, set park brake, remove key, and wait for all moving parts to stop.**

2.4 MAINTENANCE SAFETY

1. Read and follow ALL general, operating, maintenance and safety information in this manual.
2. Support the machine with blocks or safety stands when changing tires or working beneath it.
3. Set Blower on the ground, stop engine, set park brake, remove ignition key and wait for all moving parts to stop before operating, servicing or adjusting.
4. Make sure all guards are in place and properly secured when operating or maintaining the Blower.

Buffalo Turbine Warranty Policy

3.0 MACHINE WARRANTY INFORMATION

Buffalo Turbine warrants the DEBRIS BLOWER, to the original owner, to be free from defects in material and workmanship, under normal use and service. **All machines must have a completed registration form sent to Buffalo Turbine within 30 days of purchase for warranty to apply.** Obligation under this warranty shall extend for a period of 10 years from date of purchase and, at the option of Buffalo Turbine, replacement of any parts found, upon inspection by Buffalo Turbine, to be defective. Any parts replaced under warranty will have the remainder of the warranty from the original date of purchase.

Warranty parts during first 2 years will be shipped free of charge via standard ground shipping

If expedited shipping is required charges will be paid by the end user

Year 1: parts and labor

Year 2: parts only

Customer will be required to pay shipping charges for years 3-10

Year 3: Engine, per engine manufacturer's standard / Turbine Assembly / Frame (parts only)

Year 4-10: Turbine Assembly / Frame (parts will be prorated)

Buffalo Turbine reserves the right to incorporate improvements in material and design of its products without notice and is not obligated to make the same improvements to equipment previously manufactured.

ALL WARRANTY REPAIRS NEED PRE-APPROVAL BY A FACTORY PERSON (FROM BUFFALO TURBINE) PRIOR TO COMMENCING WITH A WARRANTY REPAIR TO INCLUDE SERIAL NUMBER AND HOURS FROM HOUR METER (IF EQUIPPED). PRE-APPROVAL WILL BE REQUIRED BY THE END USER AND DEALER/DISTRIBUTOR LEVEL.

Factory ordered Buffalo Turbine parts must be used when filing a warranty claim.

LIMITATIONS OF LIABILITY

This warranty is expressly in lieu of all other warranties expressed or implied and all other obligations or liabilities on our part of any kind or character, including liabilities for alleged representations or negligence. We neither assume nor authorize any other person to assume on our behalf, any liability in connection with the subsequent sale of the **DEBRIS BLOWER**. This warranty shall not apply to any DEBRIS BLOWER, which has been altered outside the factory in any way so as, in the judgment of Buffalo Turbine, to affect its operation or reliability, or which has been subject to misuse, neglect, or accident. This warranty does not cover parts and accessories, which are under separate guarantee from the manufacturers and service can be, obtained from their service facilities. No warranty is extended to regular service items such as lubricants, belts, paint and the like.

Original Instruction Manual

The Purchaser acknowledges having receiving training in the safe operation of the DEBRIS BLOWER and further acknowledges that Buffalo Turbine does not assume any liability resulting from the operation of the DEBRIS BLOWER in any manner other than described in the Operator's Manual supplied at the time of purchase.

WARRANTY VOID IF NOT REGISTERED (see Page 2 for warranty registration form)

DO NOT SPLIT THE TURBINE HOUSING FOR ANY REASON.

DO NOT ATTEMPT TO SERVICE OR DISASSEMBLE THE TURBINE BLOWER.

DO NOT USE THE TOP OF THE TURBINE HOUSING TO STRAP OR TIE DOWN BLOWER UNITS.

Unauthorized service work on the Turbine Blower will null and void all warranties.

If there are any questions regarding any of our products call Buffalo Turbine at 716 592 2700.

3.1 Warranty Registration Form

BUFFALO TURBINE

WARRANTY REGISTRATION FORM & INSPECTION REPORT

Any units not registered with Buffalo Turbine are not eligible for warranty claims
This form must be filled out by the dealer and signed by both the dealer and the customer at the time of delivery

Customer's Name _____ Dealer's Name _____

Address _____ Address _____

City, State, Zip, Country _____ City, State, Zip, Country _____

Email Address (important) _____ Email Address _____

Telephone Number _____

Blower Model _____

Circle one:

Serial Number _____

Commercial Use

Delivery Date _____

Private Use

DEALER INSPECTION REPORT

SAFETY CHECKS

_____ Tire Pressure Check -- Model KB

_____ All Decals Installed

_____ Wheel Bolts

_____ Review Operating and Safety Instructions

_____ Belt Tension

_____ Guards in Place

_____ Lubricate Machine

_____ Fasteners Tight

_____ Trailer assembly bolts properly installed and tightened

ALL 3 POINT HITCH MODELS: PTO SHAFTS MUST TELESCOPE IN EVERY POSITION

I have thoroughly instructed the buyer on the above described equipment which reviews the included Operator's Manual content, equipment care, adjustments, safe operation and applicable warranty policy.

Date _____

Dealer's Rep. Signature _____

The above equipment and Operator's Manual has been received by me and I have been thoroughly instructed as to the care, adjustments, safe operation and applicable warranty policy.

Date _____

Owner's Signature _____

PLEASE EMAIL TO BUFFALO TURBINE AT - service@buffaloturbine.com

Or fax to 716 592 2460

4.0 OPERATIONS

4.1 TO THE NEW OPERATOR OR OWNER

Buffalo Turbine Debris Blowers are designed to quickly and efficiently, blow away leaves, cuttings and other debris. The material is conveyed on a stream of high volume and velocity of air to remove it from the area of concern. When the material is removed, it gives a neat, professional look to the working area.

Many of the features incorporated into the machine are the result of suggestions made by customers like you. Read the manual carefully to learn to operate the machine safely and how to set it to provide maximum efficiency. The manual will take you step-by-step through your working day. By following the operating instructions in conjunction with a good maintenance program, your Blower will provide many years of trouble-free service.

Potential Mechanical Hazards while operating your machine:

Never operate the debris blower around others to prevent the possibility of being run over by equipment.

Never ride on your debris blower to prevent the possibility of being thrown off the machine or hurt severely.

Potential Crushing Hazards while operating your machine:

Between Trailer Tongue and mounting hitch on towing vehicle

Between each nozzle



WARNING:

This Product can expose you to chemicals including carbon monoxide and benzene, which are known to the State of California to cause cancer and birth defects or other reproductive harm.

For more information go to www.P65Warnings.ca.gov.

4.2 BREAK-IN

Although there are no operational restrictions on the Blower when it is used for the first time, it is recommended that the following mechanical items be checked:

A. Operating for first ½ hour

1. Re-torque all wheel bolts, axle nuts and trailer mounting bolts and nuts.
2. Re-torque all other fasteners and hardware.
3. Check set screw (nozzle pulley) to ensure it tightened.

B. Operating for first 5 hours

1. Re-torque all hardware and fasteners.
2. Check set screw (nozzle pulley) to ensure it tightened.
3. Go to the normal servicing and maintenance schedule as defined in the Maintenance Section of the manual.

4.3 PRE-OPERATION CHECKS

Efficient and safe operation of the Buffalo Turbine Blower requires that each operator reads and understands the operating procedures and all related safety precautions outlined in this section. A pre-operation checklist is provided for the operator. It is important for both personal safety and maintaining the good mechanical condition of the machine that this checklist is followed.

BATTERY MUST BE CONNECTED BEFORE OPERATION (DISCONNECTED FOR SHIPPING).

Before Operating the Blower and each time thereafter, the following areas should be checked off.

1. For fuel, oil, and operating information of the Kohler Engine, refer to the Manufacturers specs included with this manual.
2. The Model CKB4SQ turf trailer is not designed for highway towing. For highway use or speeds above 15mph (24kph) an optional DOT approved trailer must be used.
3. Insure the Blower unit is attached to a proper receiver mounted on the towing vehicle. A pin hitch receptacle is standard with the model CKB4SQ. Attach the CKB4SQ trailer using the proper size hitch pin with a locking presto pin.
4. Make sure all guards and shields are in place, secured and functioning as designed.
5. Check that all clamp bands are secure.
6. Check the belts and pulleys for proper tension and alignment.

Remote Nozzle and Throttle Control

The throttle control adjusts the engine RPM from an idle to maximum RPM and the nozzle control adjusts the rotation of the nozzle assembly (360° in either direction). **NOTE: ONLY MOVE 1 NOZZLE AT A TIME TO AVOID DAMAGING NOZZLES.**

CAUTION! DO NOT ALLOW LEAVES OR DEBRIS TO ACCUMULATE ON OR NEAR THE ENGINE OR EXHAUST SYSTEM OF THE MODEL CKB4SQ BLOWER, TRACTOR ENGINE OR ANY INTERNAL COMBUSTION ENGINE.

4.4 MODEL BT-CKB4SQ Assembly Instructions

1. Fill engine oil to proper level. (overseas shipments)
2. Attach 2 axle weldments (**part# 1713**) with 2 bolts each (**part# 1137**). Do not tighten.
3. Tighten 4 axle mount bolts. Use nyloc nuts (**part# 1180**).
4. Attach axle (part # 2637) to axle mounts using 2 bolts (part # 1137). Do not tighten.
5. Tighten 4 axle mount bolts then tighten the 2 bolts holding the axle. Use nyloc nuts (part# 1180).
6. Attach the tongue using the 2 U-bolts (**part # 1707**) and 4 nyloc nuts (**part # 1180**), center on the frame then tighten evenly. Equal pressure must be applied on each hex. **Note: The tongue is reversible and will allow for 2 different heights. Determine the desired height before attaching the tongue.**
7. Attach both fenders (**part # 1150**) using (4) 3/8-16 x 1" carriage bolts (**part # 1154**), 3/8 lock washer (4) 3/8-16 hex nuts (**1155**)
8. Recheck all mounting bolts to assure that they are tight.
9. Bolt on tires.
10. Reattach positive battery cable (RED) and ground cable (Black) to proper terminals.

USE PRESTO PIN TO KEEP HITCH PIN IN PLACE WHILE OPERATING

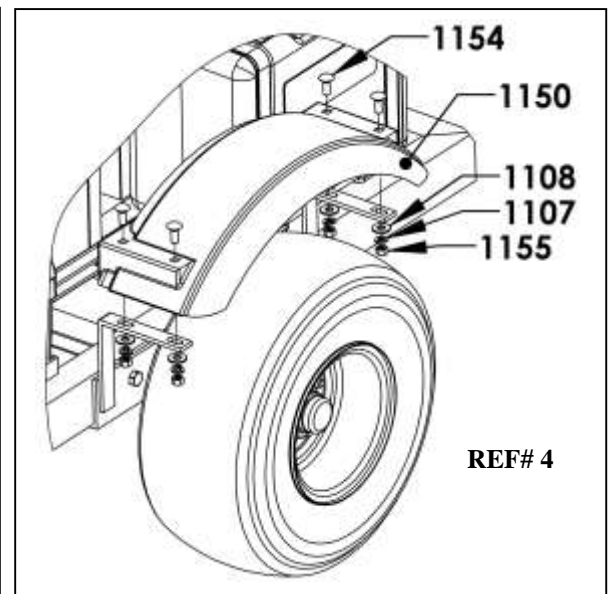
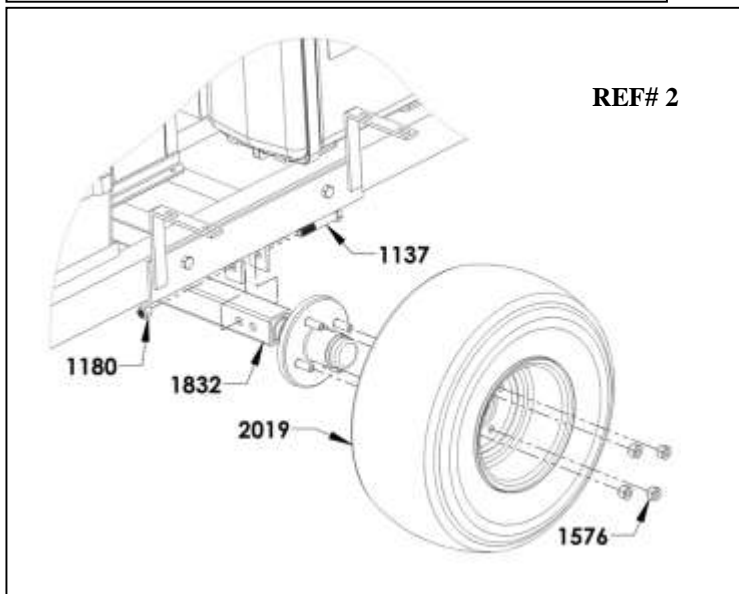
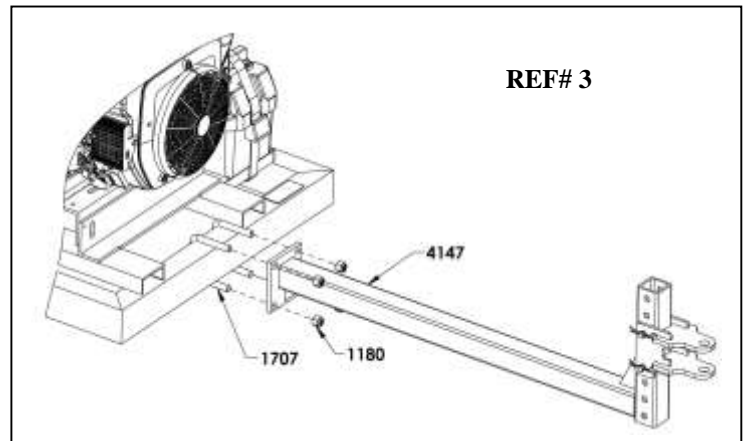
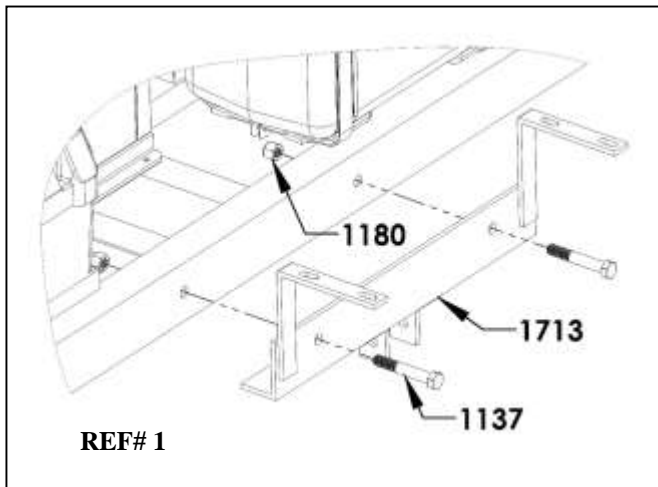

4.5 FIELD OPERATION

1. Do not direct debris blower towards people, pets, autos, windows, etc.
2. **Starting blower unit:** Always start engine at a lower engine speed with nozzle pointed down or away.
3. The air stream direction is changed (in either direction) by pressing the nozzle buttons on the transmitter. The nozzle will stop turning by releasing the transmitter button. **ALWAYS CHECK THE GROUND CLEARANCE WHEN OPERATING THE NOZZLE IN THE DOWN VERTICAL POSITION.**
4. **Stopping blower unit:** Shut engine off above ½ throttle by turning key switch to off position to avoid engine backfire.
5. Allow the blower fan speed to come to a complete stop before disconnecting from tow vehicle.

4.6 Operating RPM (All Models)

The manufacturer's engine section normally recommends the unit be run at a RPM that will insure efficient operation. The Blower can operate at a slower RPM if it can effectively move the debris. Increase engine RPM as needed.

Moving light material, such as dry leaves, requires much less wind than wet or heavier material.

Always try to blow with the wind. The Blower can be used for a wide variety of applications to move leaves, grass clippings, aeration plugs and debris. Drying wet areas has been another use with these powerful Debris Blowers.

4.7 Storage

At the end of the working season or before storing the blower unit, prepare the machine by following this procedure:

1. Select a storage area that is dry, level and free of debris.
2. Thoroughly wash the machine with a water hose to remove all debris and residue.
3. Run the machine at low RPM to dry the Blower Components.
4. Touch up all paint chips and scratches to prevent rusting.
5. Inspect for worn or failed components. Order the replacement parts and repair the blower unit when time allows. This will eliminate unnecessary down time at the start of next season.
6. Store in an enclosed building. If space is not available, cover with a waterproof tarpaulin and tie it down securely.
7. Store the machine away from areas of human activity.
8. Do not allow children to play around the stored unit.

5.0 BT-CKB4SQ Machine Specifications

	Frame Size 28" wide X 48" Long
	112" With nozzle
Length:	92" Without nozzle
	75" With nozzle installed but Without trailer arm
	55" Without nozzle and trailer arm installed
Width:	66" With fender/axle mount and tires
	48" Without fender/axle mount and tires
Height:	43" With fender/axle mount and tires
	32" Without fender / axle
Weight:	880 lbs.
Electrical System:	12 Volt battery / 350 CCA
Fuel Capacity:	8 Gallon Unleaded Fuel only
Input Power:	40HP EFI Engine
Outlet Size:	Approximately 12"

6.0 MAINTENANCE SECTION

6.1 Maintenance Safety

1. Set Blower on a level surface, stop engine, set park brake, remove ignition key and wait for all moving parts to stop before dismounting to service, adjust or repair.
2. Reinstall and secure all guards removed for servicing before starting to use machine again. *We recommend wearing gloves when removing or installing the guard to avoid getting cut*
3. Securely support machine with blocks or safety stands when changing tires or working beneath it.

6.2 Fluids

Use NLGI2 grease only for flange bearing.

Change oil per Manufacturer's specification (see Engine owner's manual section).

6.3 Greasing Interval

Grease the fittings on your new CKB4SQ Blower after the first **8** hours of operation.

40 Hours: Flange bearing (1) - approx. 2 shots of grease. Use a grease gun extension.

DO NOT OVER GREASE

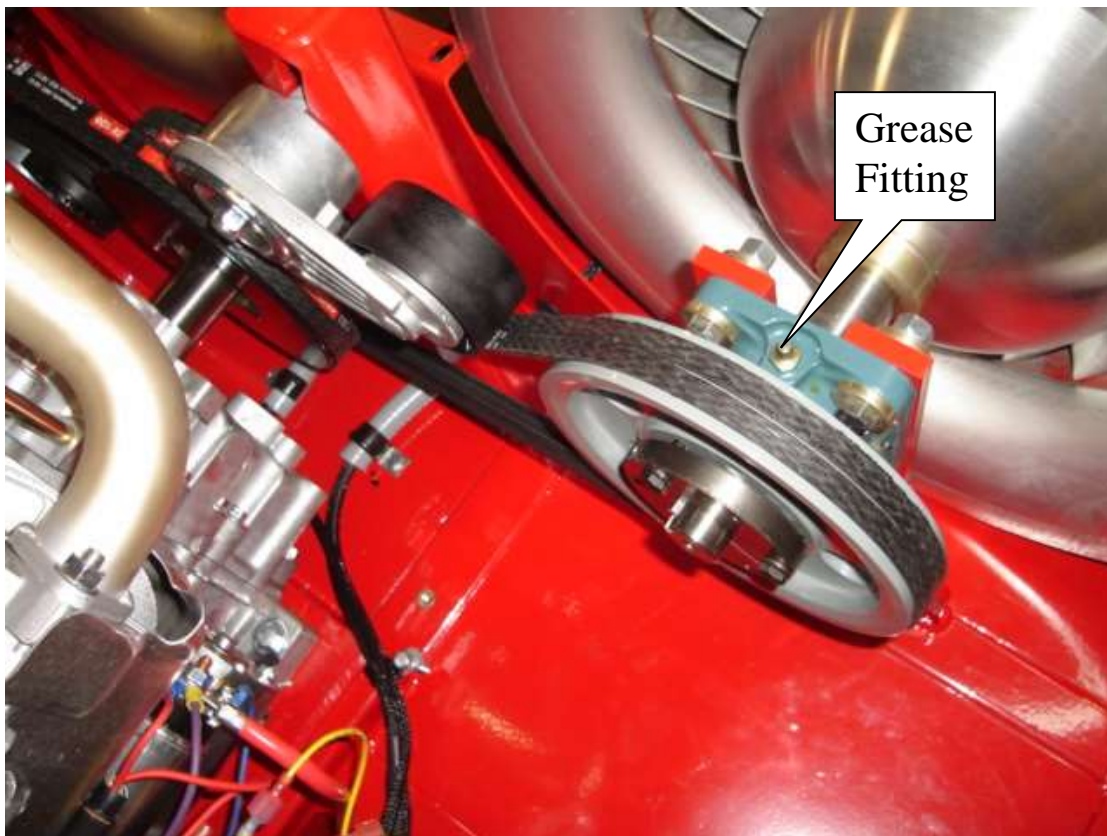

6.4 Belt Maintenance

After using the Blower unit for a long period of time, the belt will stretch and wear and need replacing.
REPLACING THE BELT

USE THE ILLUSTRATION FROM BELOW FOR REFERENCE

It is best practice to replace belts in pairs.

To change the belt follow this procedure:

Remove the guard around belts and pulleys. (Figure 1/Figure 2)

Insert a 3/8" ratchet into the square hole on tensioner housing.

Lift up on ratchet until belt can be easily removed.

Remove belt.

Replace belts with type (3V500RP Figure1/Figure 2)

Check pulley alignment with a straight edge and re-check belt tension.

Belt tension is correct when the tensioner is released and is in the center of the groove on tensioner housing.

GUARDS REMOVED FOR CLARITY

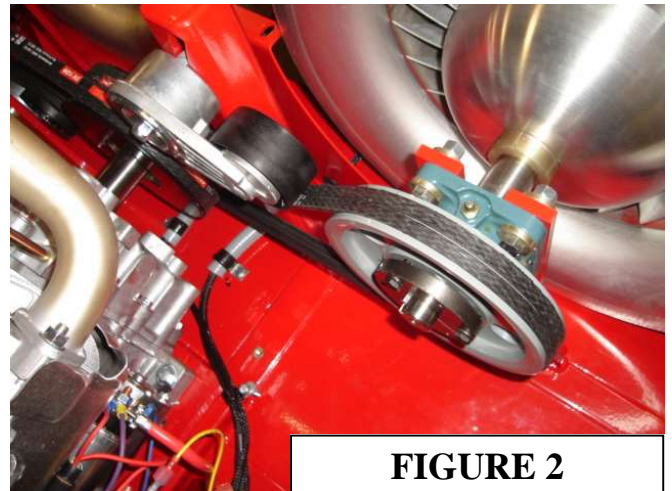
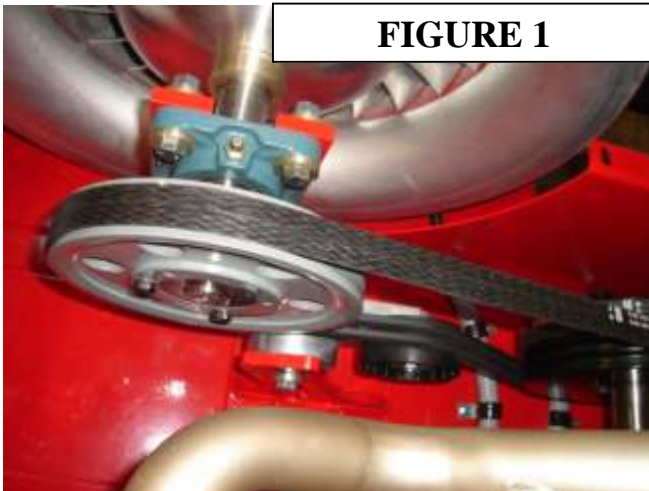

6.5 SERVICE CHECKLIST

See Lubrication and Maintenance sections for details of service. Copy this page to continue record.

TURN OFF ENGINE, REMOVE KEY & DISCONNECT BATTERY BEFORE SERVICING BLOWER UNIT

CODE: LUBRICATE-(L) / CHECK-(*) / CHANGE-(C) / REPLACE-(B) / CLEAN-(CL)

SCHEDULED MAINTENANCE HOURS _____

SERVICED BY _____

MAINTENANCE

8 hrs. or daily

- (*) Remove all debris that has settled between the blower wheel fan and the stationary vanes. Helps maintain peak performance.
- (*) Check engine oil and fill to proper level – Do not overfill
- (*) Check air filter and precleaner
- (CL) Clean debris from air intake and other cooling areas on the engine
- (*) Check tire pressure (Max. 50 PSI)
- (*) Check Clamp Band Bolt for tightness

40 hrs. or weekly

- (L) Flange bearing greasing
- (*) Inspect battery terminals for any corrosion, broken wires, or loose connections.
- (*) Remove Battery and clean debris from inside of battery box
- (L) Nozzle base slides (Teflon spray)
- (*) Check set screw (nozzle pulley) to ensure it is tightened
- (*) Wash and Clean any dirt or grime build up that has accumulated on blower wheel fan blades. Helps to minimize vibration balance and maintain peak performance.

200 hrs. or annually

- (CL) Machine

DO NOT OPERATE BLOWER UNIT WITHOUT GUARDS SECURELY ATTACHED

BT-CKB4SQ PARTS REFERENCE

(BEGINNING WITH SERIAL #38637)

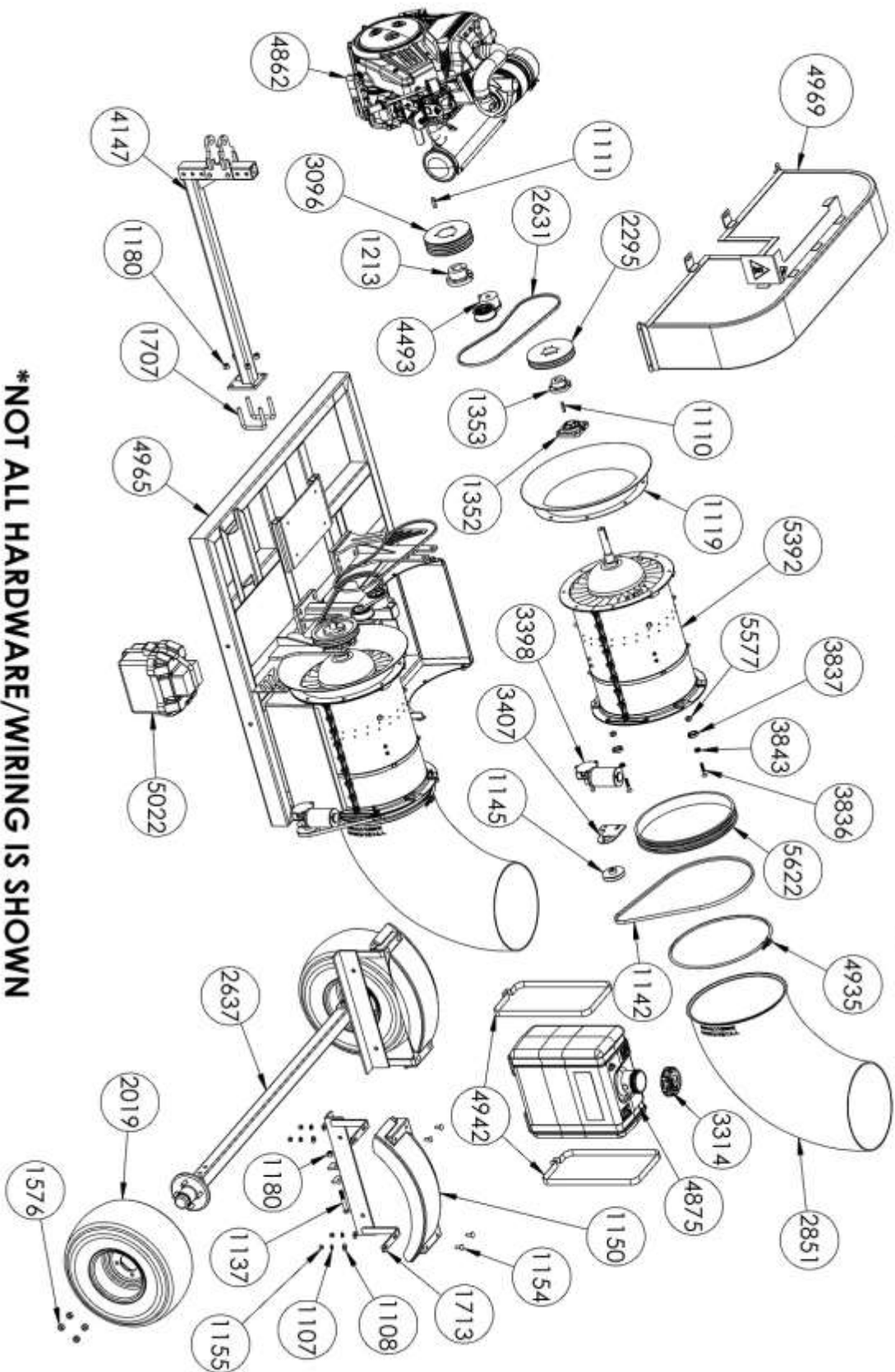

*NOT ALL HARDWARE/WIRING IS SHOWN

BT-CKB4SQ SUB ASSEMBLIES PARTS REFERENCE

PN 1153 (HUB W/ STUD RISERS)
REPLACEMENT PARTS

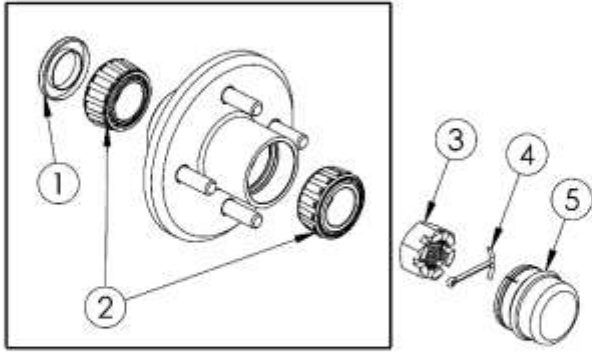

HUB ASSEMBLY PARTS REFERENCE			
Ref #	Part #	Description	Qty.
1	1691	SEAL	1
2	1690	1-1/16 TAPER ROLLER BEARING	2
3	1151	1"-14 CASTLE NUT	1
4	1152	1/8 X 1-1/2" COTTER PIN	1
5	1575	BEARING CAP	1

5022: CKB4SQ BATTERY BOX PARTS REFERENCE

Ref #	Part #	Description	Qty.
6	2306	8-32 X 7/8" PHILLIPS PAN HEAD	4
7	5031	WIRELESS RECEIVER	1
8	2026	SPACER	1
9	1378R	BATTERY BOX AND COVER	4
10	2329	8-32 NYLOC NUT	1
11	3238	BATTERY BOX STRAP	1
12	5028	8 BUTTON TRANSMITTER	1

NOTE: NOT SHOWN:
PART #: 4973 - WIRING HARNESS
QTY=1

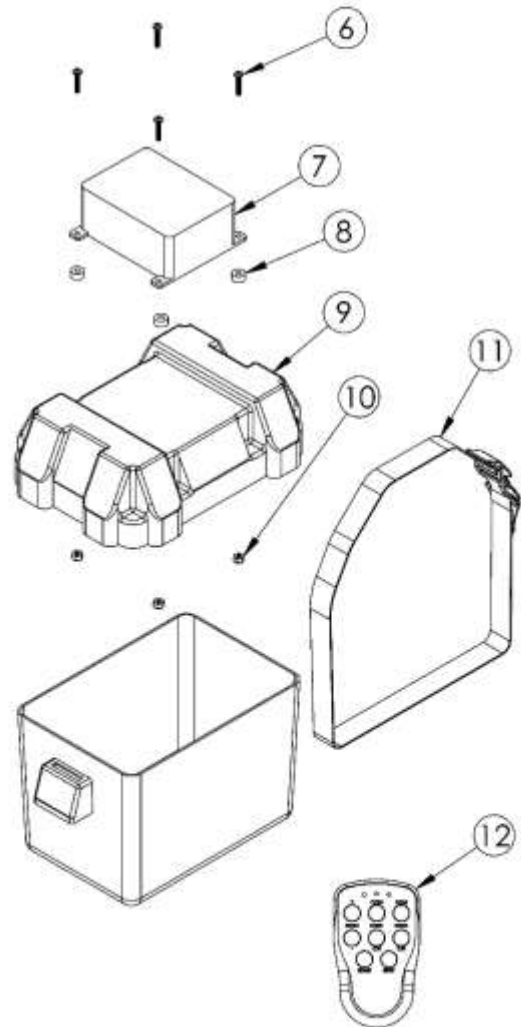

BILL OF MATERIALS FOR BT-CKB4SQ

REF PAGE #	PN	DESCRIPTION	QTY
	1100	3/8-24 X 1-1/4 HHCS ZINC GR 5	12
	1101	3/8-24 X 1-1/2 HHCS ZINC GRADE 5	6
	1102	3/8-24 X 1-3/4 HHCS ZINC GRADE 5	14
	1105	3/8-24 HEX NUT ZINC PLATED GRADE 5	40
	1106	SPACER-3/8 X 3/16 THICK WASHER	8
14	1107	3/8 LOCK WASHER ZINC PLATED	60
14	1108	3/8 FLAT WASHER ZINC PLATED	56
14	1110	KEY, 1/4 X 1-1/2	2
14	1111	KEY, 3/8 X 1-1/2	1
	1116	¼-14 HEX HEAD WASHER SELF DRILLING SCREW	2
14	1119	14-221-D1 BELLMOUTH	2
	1122	RED POSITIVE CABLE W/LUGS 24" LONG 4 GAGE	1
	1125	¼-20 NYLOC NUT ZINC	5
	1130	5/16-18 X 3/8 SET SCREW	2
14	1137	½-13 x 3-1/4 HHCS GRADE 5 ZINC	6
14	1142	A-54 V-BELT	2
14	1145	SHEAVE AK32 X ½	2
14	1150	PLASTIC FENDER	2
14	1154	3/8-16 X 1 CARRIAGE BOLT ZINC	8
14	1155	3/8-16 HEX NUT GRADE 5 ZINC	8
	1156	SERIAL TAG	1
	1158	¼" GAS LINE	86
	1166	COV ½ X ¼ WIRE CLAMP	1
	1167	COV 5/16 x ¼ WIRE CLAMP	2
	1169	¼-20 X 1HHCS ZINC	8
14	1180	½-13 NYLOC NUT ZINC	10
	1182	4X4 BT DECAL	2
	1186	CAUTION DO NOT OPERATE DECAL	2
14	1213	BUSHING, SK 1-7/16	1
	1230	3/8-16 X 1 HHCS ZINC GRADE 5	8
	1236	3/16 X 1 ROLL PIN	4
	1258	¼-20 X ¾ HHCS ZINC GRADE 5	3
	1259	¼ LOCKWASHER	16
	1271	5/16-18 HEX NYLOC NUT	5
	1275	BLACK CABLE TIES 8"	6
14	1352	1" FLANGE BEARING	2
14	1353	1" SDS BUSHING	2
	1415	¼" FLAT WASHER	8
	1419	5/16-18 X 2 HHCS ZINC GRADE 5	4
	1541	5/16 FLAT WASHER	4
14	1576	½-20 LUG NUT	8
	1669	¼-20 X .055 HEAD INSERT	8
14	1707	U-BOLT	2
14	1713	AXLE MOUNT WELDMENT	2
	1726	3/8-24 X 3" HHCS ZINC GRADE 5	1
	1819	BLACK CABLE TIES, 12" LONG	2
	1820	5/16-18 X ¾" LONG HHCS ZINC GRADE 5	1
	1935	3/8-24 NYLOC NUT	2
	1964	10-32 X ½" LONG SHCS	1
14	2019	18" X 8 ½" X 8" 4PLY SAWTOOTH TIRE ON 8X7, 4-4 WHITE RIM	2
	2076	INSULATED FEMALE QUICK DISCONNECT	6
14	2295	2/3V6.90 SDS SHEAVE	2

	2305	3/8-24 X 2-1/4" LONG HHCS ZINC GRADE 5	4
14	2631	3V500RP BELT, OPTIBELT (SOLD AS MATCHED SETS OF 2PC)	2
14	2637	AXLE WELDMENT, SQUARED	1
	2725	1/2" LIQUID TIGHT CONDUIT	13"
14	2851	AEROSPACE POLYMER NOZZLE	2
	3007	CONSTANT TENSION HOSE CLAMP	4
	3066	3/8-24 X 4-1/2" LONG HHCS ZINC GRADE 5	1
14	3096	4/3V6.9 SPECIAL SHEAVE, SQUARED	1
	3164	3/4" CONDUIT CLAMP	4
	3258	TENSIONER POST WELDMENT	1
	3261	TENSIONER BRACKET WELDMENT	1
14	3314	EPA APPROVED FUEL CAP	1
	3333	1/2" BRAIDED CABLE SLEEVING	10
	3336	5/16" CONSTANT TENSION HOSE CLAMP	1
14	3398	ROTATION MOTOR	2
14	3407	ROTATION MOTOR BRACKET	2
14	3836	3/8-24 X 2" LG FHCS	8
14	3837	ELBOW BASE RING BEARING	8
14	3843	BEARING BUSHING	8
	4088	HITCH ATTACHMENT WELDMENT	1
	4109	TONGUE WELDMENT	1
	4117	1/2" CLEVIS PIN, 3" LONG	2
14	4147	TONGUE ASSEMBLY, ADJUSTABLE	1
	4314	TUBE FITTING, 1/4" X 3/16" REDUCER	1
14	4493	TENSIONER ASSEMBLY	2
	4725	WARNING DECAL-EAR, EYE PROTECTION & THROWN OBJECT	2
	4726	CYCLONE DECAL	2
14	4862	40HP EFI ENGINE	1
14	4875	6 GALLON FUEL TANK, EPA/CARB	1
14	4935	CLAMP BAND	2
14	4942	GAS TANK STRAP	2
14	4965	FRAME, BT-CKB4SQ	1
14	4969	SQUARED GUARD, ONE PIECE	1
	4972	350CCA BATTERY	1
	5002	VANGUARD 40HP JUMPER HARNESS	1
14, 15	5022	SQUARED EFI BATTERY BOX ASSEMBLY	1
	5024	OIL DRAIN VALVE	1
	5029	OIL DRAIN HOSE	1
	5048	MODIFIED VANGUARD 40HP ENGINE HARNESS	1
	5193	1/4-28 X 3/4" LONG HHCS SERRATED FLANGE GRADE 5 ZINC	6
14	5392	RED, RH 14" BLOWER ASSEMBLY SINGLE BEARING	2
14	5577	BEARING SPACER (BACK SIDE OF TURBINE HOUSING)	8
14	5622	THICK-FLANGE BASE RING KIT (INCLUDES BASE RING, BEARINGS, BUSHINGS AND HARDWARE)	2
	5649	16" 4 AWG BLACK CABLE W/LUGS	1

7.0 TROUBLE SHOOTING

The Buffalo Turbine Debris Blower uses a high volume and velocity of air to move material from one place to another. The system is simple and reliable requiring minimal maintenance.

If you encounter a problem that is difficult to solve, even after reading through this trouble shooting section, please call your local dealer or distributor. **Before calling, please have this Operator's Manual and the serial number from your Blower ready.**

In the following section, we have listed causes and solutions to the problems that you may have encountered.
TURN OFF ENGINE, REMOVE KEY, AND DISCONNECT BATTERY BEFORE SERVICING BLOWER UNITS.
INSTALL GUARDS BEFORE OPERATING.

PROBLEM	CAUSE	SOLUTION
No air flow	Buildup of debris inside turbine	Remove nozzle and clean debris from inside turbine
No air flow	Blower fan not turning	See solutions above
Reduced or no air flow	Blower fan turns	Air intake or exhaust restricted Shut off engine Blower or tractor – remove restrictions Debris cannot be allowed to build up between the blower fan and stationary vanes
Machine vibrates or Unusual sounds	Bearing or coupling failure Out-of-balance	Replace bearings or coupling check blower for damaged blades Wash and clean blower fan blades
No throttle control		See diagnostic tests on pages 21
No nozzle control		See diagnostic tests on pages 22-23
Engine will not Start with Remote		See diagnostic test on page 24

BUFFALO TURBINE WIRELESS REMOTE SYSTEM MANUAL FOR BT-CKB4SQ

Specifications:

Receiver

(BT PN 5031) WIRELESS RECEIVER

Transmitter

(BT PN 5028) WIRELESS TRANSMITTER

Environmental

Supply Voltage: 12VDC

Signal Analog Voltage Ramp (V/Sec): 4.6/6

Functional Relays: functional relays makes/ breaks 8A ACI

Transmit Frequency: 2405-2480 MHz

Number of Freq. Channels: 16

IP Class: IP65

Battery Type: 3 x 1.5 V - AAA alkaline

Operating Time: Approx. 15 h. with continuous usage

Operation

Operation of the controlled device is performed with the Nozzle and Throttle buttons on the transmitter. The Nozzle buttons are used to rotate the Nozzle clock (⌚) wise or counter clock wise (⌚). The Throttle buttons (+) increase and (-) decrease the engines throttle.

- Analog Signal Ramp Range (DCV): 0 to 10 increase (+) / 10 to 0 decrease (-)
- Releasing the + or - buttons at any time during an increase/decrease command will result in the control voltage to remain at a proportional value between 0 and 10 volts.
- At any time the operator can press both + and - buttons simultaneously to return the variable output to 0 volts resulting in the engine's throttle be set back to low idle.

Pairing Transmitter (TX) to Receiver (RX)

This procedure should be used to pair a single transmitter to the receiver. If you need multiple transmitters paired to this Receiver contact Buffalo Turbine at 716-592-2700 for assistance.

The following steps will completely erase any previously stored transmitter out of the receiver's memory making them obsolete. You have 10 seconds to complete these procedures after turning the engine key switch to the run position.

1. Engine key switch should be in the "OFF" position.
2. Switch on the back of the Transmitter needs to be in "ON" Position.
3. Firmly press and hold transmitter buttons Throttle +, Throttle -, and Nozzle 1 CCW (⌚) simultaneously.
4. While holding down the three buttons, turn the engine key switch ON, supplying power to receiver.
5. Keep holding down these three buttons for 6-10 seconds in which time the nozzle should start to move.
6. Pairing has been successfully completed.

If a valid code from an already registered TX is received, the receiver will go directly into normal operating mode. This is to speed up the startup time.

NOTE: Breaking any warranty seal will void the equipment's warranty, consult with Buffalo Turbine at 716-592-2700 before proceeding.

BATTERIES

BATTERY TYPE: 3 x 1.5 V

AAA alkaline

OPERATING TIME: Approx. 15 h. with continuous usage

WARNING! Do not recharge! Attempts to recharge may cause rupture, or the leaking of hazardous liquids which will corrode the equipment.

CHANGE THE BATTERIES

1. Remove the clip (2 screws).
2. Remove the battery cover (2 screws).
3. Remove the batteries, starting with the one in the middle.
4. Put the new batteries in (3 x 1.5V AAA batteries), starting with the battery to the left or to the right.
5. put back the battery cover (2 screws).

BATTERY PRECAUTIONS

Observe the following warnings.

- As batteries contain flammable substances such as lithium or other organic solvents, they may cause heating, rupture or ignition.
- Risk of explosion if battery is replaced with a battery of an incorrect type.
- Do not short circuit, disassemble, deform or heat batteries.
- Never try to charge a visibly damaged or frozen battery.
- Do not charge rechargeable batteries with a higher voltage than specified.
- Keep batteries out of reach of small children. Should a child swallow a battery, consult a physician immediately.
- Avoid direct soldering to batteries.
- When discarding batteries, insulate the + and - terminals of batteries with insulating/ masking tape. Do not put multiple batteries in the same plastic bag.
- When improperly disposed, lithium batteries may short circuit, causing them to become hot, burst or ignite.
- Store in a cool location. Keep batteries away from direct sunlight, high temperature, and high humidity.
- Do not throw batteries into fire.

DISPOSAL OF BATTERIES AND ELECTRONICS

An alkaline battery does not contain mercury, cadmium or lead, and is better for the environment than older types of batteries. Alkaline batteries should be disposed through local recycling stations/waste dumps. Contact your local government's recycling or solid waste department for more information on proper recycling of alkaline batteries in your region.

Improperly disposed batteries and electronics may harm public health and the environment. Batteries and electronic waste may contain toxic heavy metals. If thrown away in the trash, the toxic compounds can leach into soil and water, pollute lakes and streams, making them unfit for drinking, swimming, fishing, and wildlife. Contact your local government's recycling or solid waste department for more information on proper disposal of batteries and electronics in your region.

GUARANTEE, SERVICE, REPAIRS AND MAINTENANCE FOR WIRELESS SYSTEM

Buffalo Turbine products are covered by a guarantee against material, construction and manufacturing faults. During the guarantee period, Buffalo Turbine may replace the product or faulty parts. Work under guarantee must be authorized by Buffalo Turbine.

The following is not covered by the guarantee: Faults resulting from normal wear and tear, parts of a consumable nature, any Product that has been subject to unauthorized modifications, a faults resulting from incorrect installation or use, and any failure due to damp and/or water damage.

Repairs and maintenance must be authorized by Buffalo Turbine. Use spare parts from Buffalo Turbine only. Contact Buffalo Turbine at 716-592-2700 if you require service or other assistance. Keep the product in a dry, clean place. Keep contacts and antennas clean. Wipe off dust using a slightly damp, clean cloth. Never use cleaning solutions or high-pressure water.

Troubleshooting for CKB4SQ Remote / Receiver

Symptom – Does not throttle up properly.

1. **Disconnect grey plug connected to the receiver. Grey plug must be removed by compressing the side tabs and pulling straight out as shown in Ref #1. Check to ensure that each wire is securely attached to the grey connector plug (see Ref #2). Ref # 2 shows a defective grey plug.**
 - If wires will not pull out of the grey connector plug, reattach connector plug to the receiver and proceed to step 2.
 - If wire(s) pull out of connector plug, wire harness needs to be replaced.(see ref # 2)

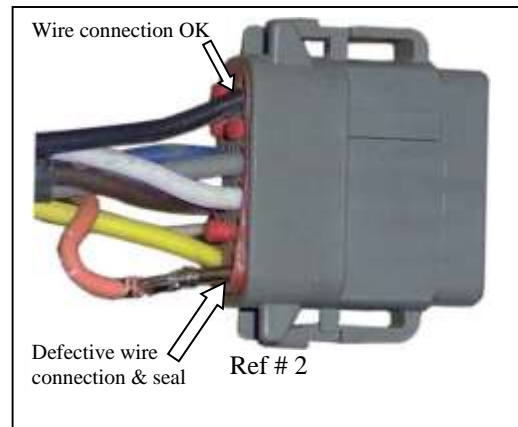
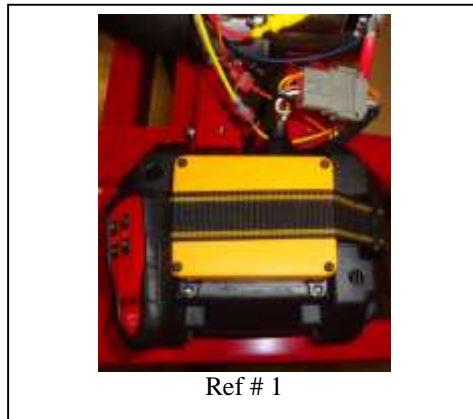

2. **Check Remote Transmitter by pressing each button to ensure that the light on Transmitter has a green light.**



- If the LED lights do not appear when pressing each button on the transmitter, replace transmitter batteries. If the LED lights still fail to function after replacing the batteries, replace the transmitter.
- If the lights operate correctly cycle key switch and retest throttle controls
- If the engine still does not go to full throttle, contact Buffalo Turbine at 716-592-2700.

Troubleshooting for CKB4SQ Remote / Receiver Kit

Symptom: Nozzle will not rotate properly.

1. Disconnect grey plug connected to the receiver. Grey plug must be removed by compressing the side tabs and pulling straight out as shown in Ref #1. Check to ensure that each wire is securely attached to the grey connector plug (see Ref #2). Ref # 2 shows a defective grey plug.
 - If wires will not pull out of the grey connector plug, reattach connector plug to the receiver and proceed to step 2.
 - If wire(s) pull out of connector plug, wire harness needs to be replaced.(see ref # 2)

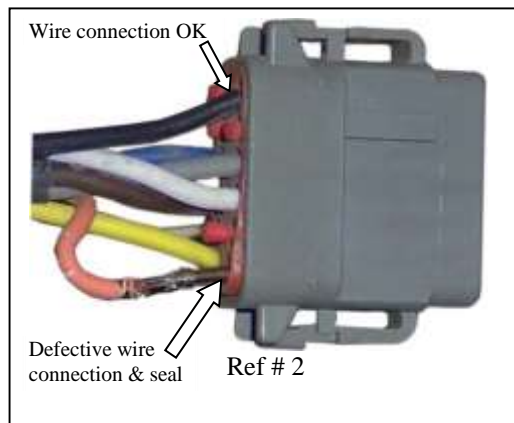
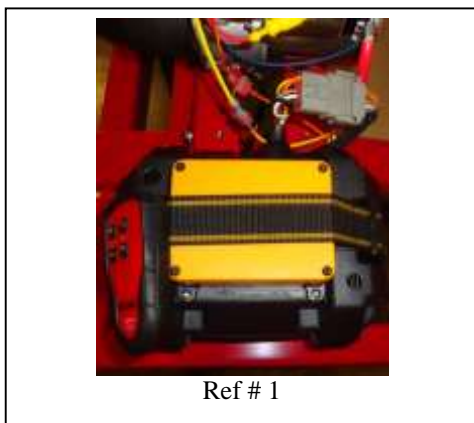

2. 2. Check Remote Transmitter by pressing each button to ensure that the light on Transmitter has a green light.



- If the LED lights do not appear when pressing each button on the transmitter, replace transmitter batteries. If a LED lights still fail to function after replacing the batteries, replace the transmitter.
 - If the lights functions correctly, proceed to step #3
3. Check the set screw on the rotation motor pulley to make sure pulley is not loose and spinning on the shaft.
 - If set screw is loose, rotate nozzle assembly until pulley and flat spot on shaft are aligned. Tighten set screw and test nozzle functions with remote.
 - If set screw is tight, proceed to step #4

4. With the engine key switch in the run position, disconnect the nozzle wires leading from the rotation motor and wire harness (white and grey) at the quick disconnects. The following test will require an electronic multi-meter, set to read at least 12 volts.

- Insert the red probe into the white wire and black probe into the grey wire. Press the nozzle buttons CW or CCW. (Voltage should read approx. +12 volts in one direction and approx. – 12 volts in the opposite direction.) If the proper voltage is confirmed and all wire connections are secure, proceed to step # 5



- If proper voltage has not been verified contact Buffalo Turbine for further instructions.

5. Apply power to the rotation motor directly. Both wires from rotation motor need to be connected to the battery. (Ex. white to positive terminal & black to negative terminal) Then reverse the wire connections to the battery. (Ex. black to positive terminal & white to negative terminal)

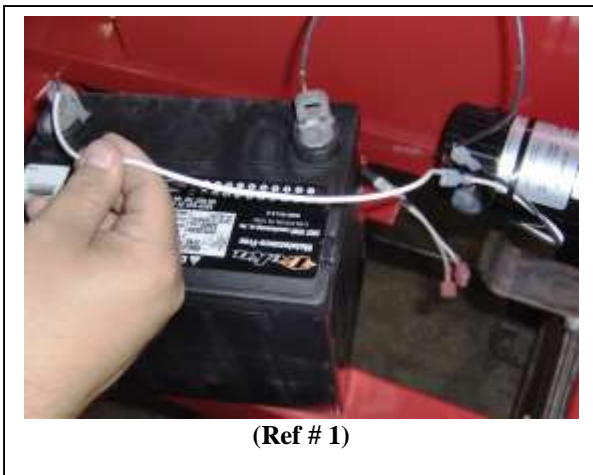

(Ref # 1)

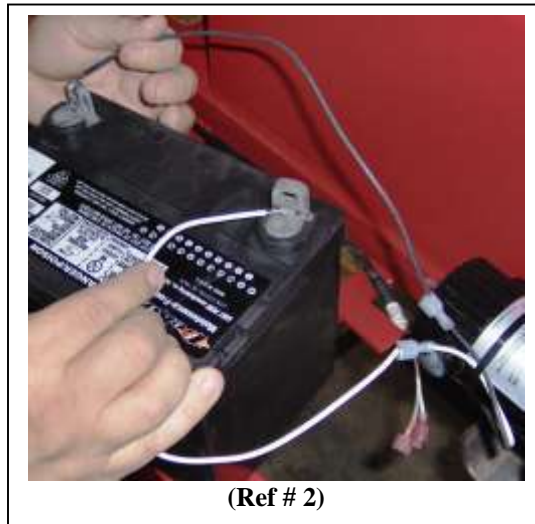

(Ref # 2)

- If rotation motor rotates in both directions, the motor is ok.
- If rotation motor will not rotate in either direction with power applied contact Buffalo Turbine.
- If rotation motor rotates in one direction but the other, contact Buffalo Turbine.

If necessary, contact Buffalo Turbine at 716-592-2700 for more instructions.

Starting the Engine Manually with the Key Switch

In addition to remote start/stop via the wireless transmitter, the debris blower can also be started manually using the key switch located on the front of the engine.

To enable manual starting, locate the fuse box on the left side of the engine. It is a black plastic box with wires coming out the bottom. Depress the tabs on both sides of the fuse box cover, and remove the cover from the fuse box.

Inside the fuse box, a blue wire with a spade connector on the end comes out of a terminal at the back of the fuse box, and the spade connector is installed in the first terminal, as shown in Image 1 below. Remove the spade connector from the first terminal and insert it into the second terminal, as shown in Image 2. The engine can now be started manually using the key switch.

To re-enable remote start/stop functionality, remove the spade connector from the second terminal and reinstall into the first terminal, as shown in Image 1.

Reinstall the fuse box cover before operating the debris blower.



Image 1 - Remote Start



Image 2 - Manual Start



TALK WITH OUR EXPERTS
 8AM-4:30PM (Mon-Fri) EST
 (716) 592-2700
www.BuffaloTurbine.com

OPTIONS

180 Zoar Valley Road
 Springville, NY 14141

NOZZLES +

Aerospace Polymer Nozzle - Part# 2851



Flexible Nozzle Assembly - Part# 3345
 Various lengths available. Ideal for rough terrain.



*Call sales and service to request custom nozzle configuration.



Gyratory Atomizing Nozzle - Part# 2547
 (Safety guard removed for clarity)



Optional aluminum nozzles **will not** connect to the standard Aerospace Polymer Nozzle (Part# 2851). Requires: **Two 45° elbow segments (Part# 1171)** and two additional clamp bands (Part# 1173).

12" Extension - Part# 1468
20" Extension - Part# 1845

10" Round Nozzle - Part# 1417
12" Round Nozzle - Part# 1172
 Improves air velocity with lower horsepower and hydraulic blower units



10" Rectangular Nozzle - Part# 1469
19" Rectangular Nozzle - Part# 1425
 5.5"x15" opening - extra length/more concentrated air flow. Uses - heavy wet debris, plugs, top dressing. No ground clearance in the vertical down position.



Fishtail Nozzle - Part# 1743
 5"x30" (wide angle) opening. Distributes a large volume of air at a lower velocity over a wide area. Easily converts blower into a "Greens Fan". Adaptable to all models. Not as effective at moving debris.



<p>D.O.T. TRAILER</p> <p>Part# 1613-D for 8000, KB4, EFI & Mega</p> 	<p>2" BALL RECEIVER HITCH</p> <p>Part# 4605</p> 	<p>FORK POCKETS</p> <p>Part# 4552 Great for moving blowers around jobsites and bed mount / skid mount applications.</p> 	<p>LINE DRIVER ATTACHMENT</p> <p>Part# 2419</p> 
<p>CORDED CONTROL</p> <p>Part# 5579 for KB7, MEGA 3 Model Part# 2787 for Diesel Model Part #5580 for Squared Model</p> 	<p>CLAMP BAND W/ BOLT & NUT</p> <p>Part# 1173</p> 	<p>QUICK CONNECT CLAMP BAND</p> <p>Part# 4935 Quickly remove or add nozzle with the barrel style clamp band.</p> 	<p>WARNING: Cancer & Reproductive Harm - www.P65Warnings.ca.gov</p>

BUFFALO TURBINE PRODUCTS

Cyclone eKB



Cyclone 8000 (& 8000 EFI)



Cyclone KB7



Cyclone MEGA



**The Original & Most Powerful
Turbine Debris
Blowers**
since 1945



BLITZ (& BLITZ MEGA)



Cyclone SQUARED



**Cyclone Hydraulic
(& Hydraulic MEGA)**



Cyclone PTO (& PTO MEGA)

Visit BuffaloTurbine.com for more product info