

BUFFALO TURBINE

180 Zoar Valley Road
Springville, NY 14141

TEL: 716 592 2700 FAX: 716 592 2460

EMAIL: info@buffaloturbine.com

WEBSITE: www.buffaloturbine.com

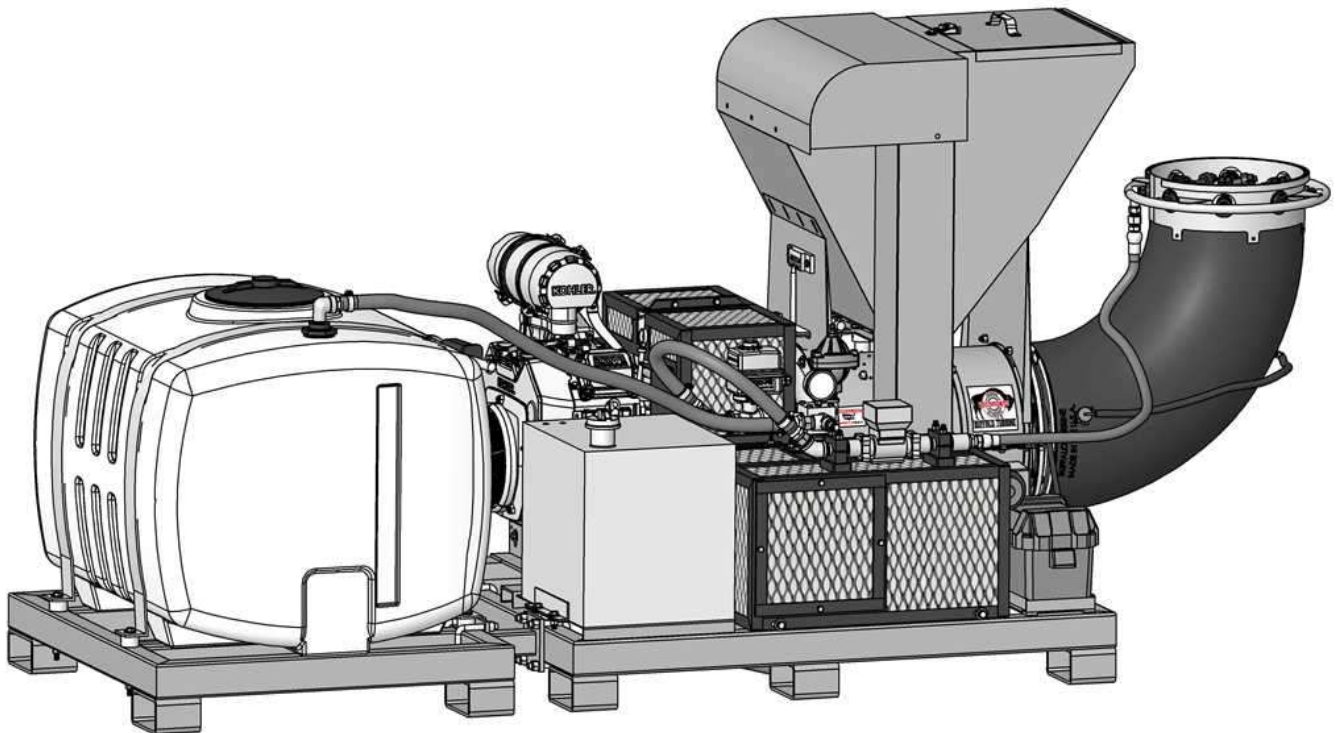

BUFFALO TURBINE'S BT-CS4G SPRAYER/GRANULAR ORIGINAL INSTRUCTIONS AND PARTS MANUAL

01/26 -BT MAN

TABLE OF CONTENTS

2.2	General Safety	5
2.3	Operating Safety	5
2.4	Maintenance Safety	6
2.5	Transport Safety	6
2.6	Storage Safety	6
2.7	Sign-off Form	6
3.0	Warranty Information	7
3.1	Warranty Registration Form	8
3.2	Parts warranty information	9
4.0	Operations	10
4.1	To the new operator or owner	10
4.2	Break-in	10
4.3	Pre-Operation Checks	10
4.4	Model BT-CS4G Assembly Instructions	11-12
4.5	Field Operation	13
4.6	Operating RPM	13
4.7	Storage	13
5.0	Troubleshooting	13
6.0	Machine Specification	14
7.0	Maintenance	15
7.1	Maintenance Safety	15
7.2	Fluids	15
7.3	Service Checklist	15
7.4	Belt Tension	16
7.5	Changing Belts	16
	Morflex Coupling Parts	17
	Morflex Coupling Installation	18
	Bill of Materials for BT-CS4G	19-21
	BT-CS4G Parts Reference	22-26
	Granular Bin Disassembly and Assembly instructions	27
	Hypro Pump Manual	28-35
	Smartflow II Manual	36-95
	Nozzle Options	96
	Buffalo Turbine Additional Products	97

1.0 INTRODUCTION

Congratulations on your choice of a Buffalo Turbine Sprayer and/or Granular machine. This equipment has been designed and manufactured to meet the needs of the Insect Control Industry.

Safe, efficient and trouble-free operation of your Buffalo Turbine Unit requires that you and anyone else, who will be operating or maintaining the Blower, read and understand all of the safety, operation, maintenance and troubleshooting information contained within this Operator's manual.

This Manual covers the BT-CS4 Models.

Keep this manual handy for frequent reference and to pass on to new operators or owners. Call your Buffalo Turbine dealer or distributor if you need assistance, information, or additional copies of the manuals.

SERIAL NUMBER LOCATION

Always give your dealer the serial number of your Monsoon when ordering parts or requesting service or other information.

The serial number plate(s) is located where indicated in the pictures below. Please document the number in the space provided for easy reference.

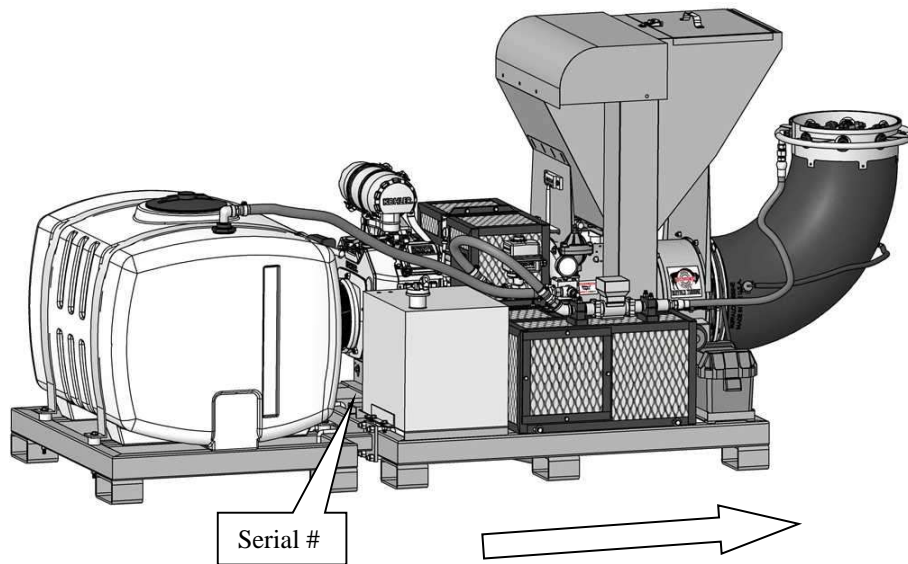

OPERATOR ORIENTATION – The directions left, right, front and rear, as mentioned throughout the manual, are as seen from the driver's seat and facing in the direction of travel.

MODEL BT-CS4G RIGHT FRONT TOP SURFACE OF FRAME

Serial Number: _____

2.0 SAFETY

YOU are responsible for the **SAFE** operation and maintenance of your Buffalo Turbine Sprayer and /or Granular unit. **YOU** must ensure that you and anyone else, who is going to operate, maintain or work around the Buffalo Turbine Sprayer and/or Granular unit be familiar with the operating and maintenance procedures and related **SAFETY** information contained in this manual. This manual will take you step-by-step through your working day and alerts you to all good safety practice while operating the Monsoon.

Remember **YOU** are the key to safety. Good safety practices not only protect you but also the people around you. Make these practices a working part of your safety program. Be certain that **EVERYONE** operating this machine is familiar with the procedures recommended and follows safety precautions. Remember most accidents can be prevented. Do not risk injury or death by ignoring good safety practices.

- Sprayer/granular unit owners must give operating instructions to operators or employees before allowing them to operate the unit, and at least annually thereafter.
- The most important safety device on this equipment is a **SAFE** operator. It is the operator's responsibility to read and understand ALL Safety and Operating instructions in the manual and to follow these. All accidents can be avoided.
- A person who has not read and understood all operating instructions is not qualified to operate the machine. An untrained operator exposes themselves and bystanders to possible serious injury or death.
- Do not modify the equipment in any way. Unauthorized modification may impair the function and/or safety which could affect the life of the equipment.
- Think **SAFETY!** Work **SAFELY!**

This Safety Alert symbol means **ATTENTION! BECOME ALERT! YOUR SAFETY IS INVOLVED!**

The Safety Alert symbol identifies important safety messages on the Buffalo Turbine Sprayer and/or Granular unit and in the manual. When you see this symbol, be alert to the possibility of personal injury or death. Follow the instructions in the safety message.

Why is SAFETY important to you?



**3 Big Reasons: Accidents Disable and Kill
Accidents Cost
Accidents Can Be Avoided**

SIGNAL WORDS: Note the use of the signal words **DANGER**, **WARNING** and **CAUTION** with the safety messages. The appropriate signal word for each message has been selected using the following guidelines

1. **DANGER** –injury or death if the proper precautions are not taken.
2. **WARNING** -- A specific hazard or unsafe practice that **COULD** result in severe personal injury or death if proper precautions are not taken.
3. **CAUTION** – Unsafe practices that **COULD** result in personal injury if proper practices are not taken, or as a reminder of good safety.

The Safety Alert symbol identifies important safety messages on the Buffalo Turbine Sprayer and/or Granular unit and in the manual. When you see this symbol, be alert to the possibility of personal injury or death. Follow the instructions in the safety message.

2.1 SAFETY DECALS

The types of decals on the blower unit are shown below. Good safety requires that you familiarize yourself with the various Safety Decals, the type of warning and the area, or particular function related to that area that requires your **SAFETY AWARENESS.* THINK SAFETY! WORK SAFELY!**

!ATTENTION!

1. **KEEP HANDS, FEET AND CLOTHING AWAY FROM POWER DRIVEN PARTS.**
2. **STOP ENGINE AND REMOVE KEY BEFORE LEAVING OPERATOR'S POSITION.**
3. **MACHINE MUST COME TO A COMPLETE STOP BEFORE ANY MAINTENANCE, TO INCLUDE ADJUSTING, LUBRICATING OR CLEANING, IS PERFORMED.**
4. **KEEP PEOPLE AND PETS AT SAFE DISTANCE FROM MACHINE.**
5. **KEEP ALL GUARDS AND SHIELDS IN PLACE.**

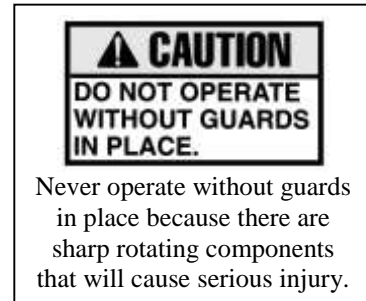
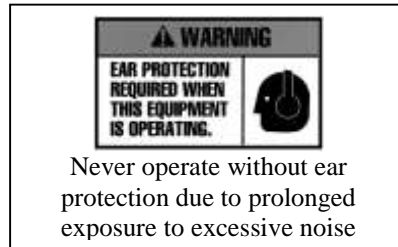
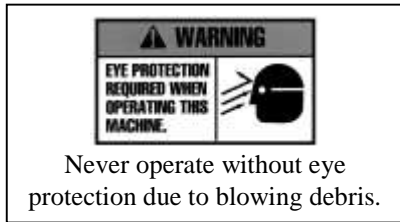

REMEMBER – If safety decals have been damaged, removed, become illegible or parts replaced without decals, new decals must be applied. New decals are available from your authorized dealer.

2.2 GENERAL SAFETY

1. Read and understand the Operator's Manual and all safety signs before operating, maintaining, and adjusting.
2. Provide a first-aid kit for use in case of an accident. Store in a highly visible place.
3. Provide a fire extinguisher for use in case of an accident. Store in a highly visible place.
4. Wear appropriate protective gear. This list includes but is not limited to:
 - A hard hat
 - Protective shoes with slip resistant soles
 - Protective glasses or goggles
 - Heavy gloves
 - Wet weather gear
 - Hearing protection
5. Do not operate without guards or shields properly installed.
6. Do not allow riders.
7. **Wear appropriate ear protection for prolonged exposure to excessive noise.**
8. **(All Models) Set Blower on the ground, stop engine, chock wheels, remove ignition key and wait for all moving parts to stop before dismounting to service or adjust.**
9. Clear the area of people, especially small children, before starting the unit.
10. Review all safety related items annually with all personnel who will be operating or maintaining the Blower.
11. Keep hands, feet, hair and clothing away from moving parts. Operate equipment only while seated in the operator's seat.

2.3 OPERATING SAFETY

1. Read and understand the Operator's Manual and all safety signs before operating, servicing or adjusting.
2. Before servicing or repairing, **Set sprayer and/or granular unit on the ground, stop engine, chock wheels, remove key, and wait for all moving parts to stop.**

Buffalo Turbine Sprayer and/or Granular Unit

3.0 WARRANTY

Buffalo Turbine warrants the Sprayer and/or Granular unit to be free from defects in material and workmanship, under normal use and service. Obligation under this warranty shall extend for a period of 1 year (12 months) and shall be limited to, at the option of Buffalo Turbine, replacement of any parts found, upon inspection by Buffalo Turbine, to be defective.

Buffalo Turbine reserves the right to incorporate improvements in material and design of its products without notice and is not obligated to make the same improvements to equipment previously manufactured.

WARRANTY CLAIMS- Buffalo Turbine Must be Notified Prior to Performing any Warranty Repairs:

The purchaser claiming under this warranty shall submit a warranty claim in the prescribed form to Buffalo Turbine or an Authorized Dealer for inspection by an authorized company representative.

Factory ordered Buffalo Turbine parts must be used when filing a warranty claim.

LIMITATIONS OF LIABILITY

This warranty is expressly in lieu of all other warranties expressed or implied and all other obligations or liabilities on our part of any kind or character, including liabilities for alleged representations or negligence. We neither assume nor authorize any other person to assume on our behalf, any liability in connection with the subsequent sale of the **Sprayer and/or Granular unit**.

This warranty shall not apply to any Sprayer and/or Granular unit, which has been altered outside the factory in any way so as, in the judgment of Buffalo Turbine, to affect its operation or reliability, or which has been subject to misuse, neglect, or accident.

This warranty does not cover parts and accessories, which are under separate guarantee from the manufacturers and service can be, obtained from their service facilities. No warranty is extended to regular service items such as lubricants, belts, paint and the like. **(See Page 8)**

Original Instruction Manual

The Purchaser acknowledges having receiving training in the safe operation of the Sprayer and/or Granular unit and further acknowledges that Buffalo Turbine does not assume any liability resulting from the operation of the Sprayer and/or Granular unit in any manner other than described in the Operator's Manual supplied at the time of purchase.

WARRANTY VOID IF NOT REGISTERED (see Page 7 for warranty registration form)

If there are any questions regarding any of our products call Buffalo Turbine at 716 592 2700.

DO NOT SPLIT THE TURBINE HOUSING FOR ANY REASON.

DO NOT ATTEMPT TO SERVICE OR DISASSEMBLE THE TURBINE.

DO NOT USE THE TOP OF THE TURBINE HOUSING TO STRAP OR TIE DOWN BLOWER UNITS.

Unauthorized service work on the Sprayer and/or Granular unit will null and void all warranties.

BUFFALO TURBINE

WARRANTY REGISTRATION FORM & INSPECTION REPORT

Any units not registered with Buffalo Turbine are not eligible for warranty claims

WARRANTY REGISTRATION

This form must be filled out by the dealer and signed by both the dealer and the customer at the time of delivery

Customer's Name _____ Dealer's Name _____

Address _____ Address _____

City, State, Zip, Country _____ City, State, Zip, Country _____

Email Address (important) _____ Email Address _____

Telephone Number _____

Blower Model _____

Circle one:

Serial Number _____

Commercial Use

Delivery Date _____

Private Use

DEALER INSPECTION REPORT

SAFETY CHECKS

_____ Tire Pressure Check -- Model KB

_____ All Decals Installed

_____ Wheel Bolts

_____ Review Operating and Safety Instructions

_____ Belt Tension

_____ Lubricate Machine

_____ Guards in Place

_____ Fasteners Tight

_____ Trailer assembly bolts properly installed and tightened

ALL 3 POINT HITCH MODELS: PTO SHAFTS MUST TELESCOPE IN EVERY POSITION

I have thoroughly instructed the buyer on the above described equipment which reviews the included Operator's Manual content, equipment care, adjustments, safe operation and applicable warranty policy.

Date _____

Dealer's Rep. Signature _____

The above equipment and Operator's Manual has been received by me and I have been thoroughly instructed as to the care, adjustments, safe operation and applicable warranty policy.

Date _____

Owner's Signature _____

PLEASE FAX A COPY TO BUFFALO TURBINE AT 716 592 2460 Or
Email - service@buffaloturbine.com

3.2 Parts Warranty Information

	Manufacturer's Warranty	Who to Contact
The turbine assembly, blower wheel, frame, engine mounting rails, rotation motor mounting bracket, tongue, axle assembly, hub assembly, All belt driven components and other components manufactured by Buffalo Turbine*.	1 Year Parts and Labor	Buffalo Turbine (716) 592-2700 Or Local Authorized Buffalo Turbine Representative
Rotation Motor	1 Year Parts	Buffalo Turbine (716) 592-2700
Yellow/black Box Wireless transmitter, Receiver, Wiring harness.	1 Year Parts	Buffalo Turbine (716) 592-2700
Battery	1 Year Parts Reimbursement with Faxed receipt from new battery and Defective Battery Serial #. Up to \$30.00	El-Don Battery (716)-896-0404 Fax: (716)-896-0406
Gas Tanks	1 Year Parts	Buffalo Turbine (716) 592-2700
Battery Box	1 Year Parts	Buffalo Turbine (716) 592-2700
Tires and Wheels	1 Year Parts	Buffalo Turbine (716) 592-2700
Kohler Engines	3 Year Engine Warranty See Engine owner's Manual	Kohler Dealer http://kohlerplus.com go to: Dealer Locator
Sandevil Units		Buffalo Turbine (716) 592-2700
EQUIPMENT REGISTRATION, TO INCLUDE THE SERIAL NUMBER OF THE UNIT, WILL BE REQUIRED FOR ALL WARRANTY REPAIRS. PRE-APPROVAL BY A FACTORY PERSON (FROM BUFFALO TURBINE) PRIOR TO COMMENCING WITH A WARRANTY REPAIR, WILL BE REQUIRED BY THE END USER AND AT THE DEALER / DISTRIBUTOR LEVEL.		
REPAIR PARTS MUST BE ORDERED THROUGH AN AUTHORIZED BUFFALO TURBINE DEALER. WARRANTY REPAIR PARTS ARE SHIPPED FREE OF CHARGE VIA UPS GROUND* *If expedited shipping is required the shipping method can be altered with the expedited charges being paid by the end user*		
PLEASE CONTACT BUFFALO TURBINE'S SERVICE DEPARTMENT AT 716 592 2700 FOR ANY SERVICE QUESTION YOU MAY HAVE REGARDING THE BUFFALO TURBINE BLOWERS.		

4.0 OPERATIONS

4.1 TO THE NEW OPERATOR OR OWNER

Buffalo Turbine Sprayer and/or Granular unit are designed to spray a fine mist of water particles and/or granular giving a thorough and wide-ranged coverage. Being adjustable allows a desired degree of agitation to the foliage, with enough velocity to completely carry through the tops of trees as well as through row after row of heavy thick leaf cover in row crops.

Many of the features incorporated into the machine are the result of suggestions made by customers like you. Read the manual carefully to learn to operate the machine safely and how to set it to provide maximum efficiency. The manual will take you step-by-step through your working day. By following the operating instructions in conjunction with a good maintenance program, your Blower will provide many years of trouble-free service.

Potential Mechanical Hazards while operating your machine:

Never operate the monsoon around others to prevent the possibility of being run over by equipment.

Never ride on your monsoon to prevent the possibility of being thrown off the machine or hurt severely.

Potential Crushing Hazards while operating your machine:

Between Trailer Tongue and mounting hitch on towing vehicle



WARNING:

This Product can expose you to chemicals including carbon monoxide and benzene, which are known to the State of California to cause cancer and birth defects or other reproductive harm.

For more information go to www.P65Warnings.ca.gov.

4.2 BREAK-IN

Although there are no operational restrictions on the Blower when it is used for the first time, it is recommended that the following mechanical items be checked:

A. Operating for first ½ hour

1. Re-torque all wheel bolts, axle nuts and trailer mounting bolts and nuts.
2. Re-torque all other fasteners and hardware.
3. Check set screw (nozzle pulley) to ensure it tightened.

B. Operating for first 5 hours

1. Re-torque all hardware and fasteners.
2. Check set screw (nozzle pulley) to ensure it tightened.
3. Go to the normal servicing and maintenance schedule as defined in the Maintenance Section of the manual.

4.3 PRE-OPERATION CHECKS

Efficient and safe operation of the Buffalo Turbine Sprayer and/or Granular unit requires that each operator reads and understands the operating procedures and all related safety precautions outlined in this section. A pre-operation checklist is provided for the operator. It is important for both personal safety and maintaining the good mechanical condition of the machine that this checklist is followed.

BATTERY MUST BE CONNECTED BEFORE OPERATION (DISCONNECTION FOR SHIPPING).

Before Operating the Monsoon and each time thereafter, the following areas should be checked off.

1. For fuel, oil, and operating information of the Kohler Engine, refer to the Manufacturers specs included with this manual.
2. The Model CS4 machines are designed to be skid mounted. For highway use or speeds above 15mph (24kph) an optional DOT approved trailer must be used.
3. Make sure all guards and shields are in place, secured and functioning as designed.
4. Check that all clamp bands are secure.
5. Check the belts and pulleys for proper tension and alignment.

CAUTION ! DO NOT ALLOW LEAVES OR DEBRIS TO ACCUMULATE ON OR NEAR THE ENGINE OR EXHAUST SYSTEM OF THE MODEL KB BLOWER, TRACTOR ENGINE OR ANY INTERNAL COMBUSTION ENGINE.

4.4 MODEL BT-CS4 Assembly Instructions

[STEP# 1] Undo guard panel screws and remove as shown.

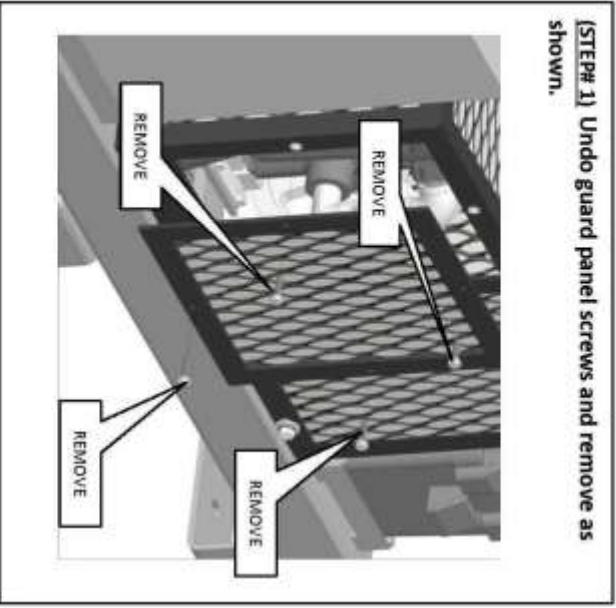

[STEP# 2] Looking through access panel, locate water in hose. Undo fitting and pull hose out from machine.

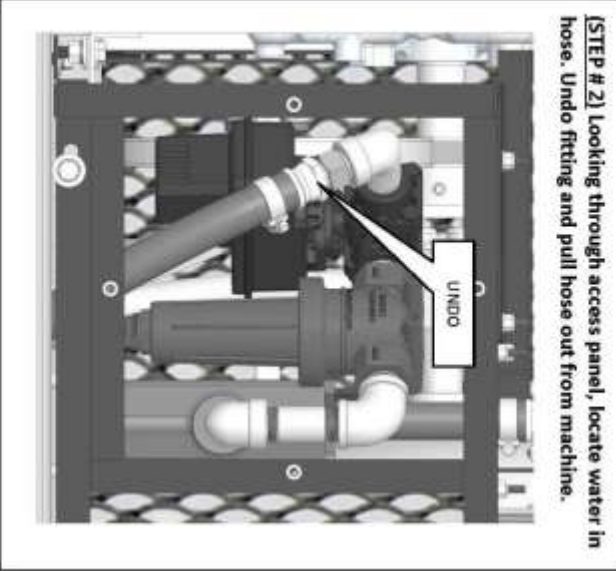

[STEP# 3] Undo return hose; make sure not to mix up the hoses because they are different lengths.

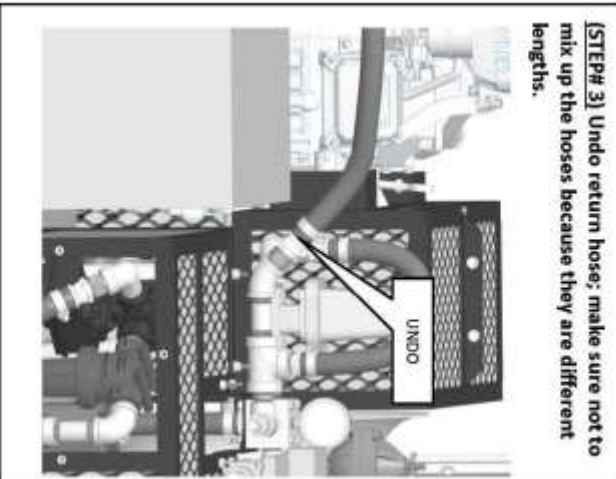

[STEP# 4] Attach hoses to 100 Gallon Tank Assembly. Make sure threads on hoses have pipe tape or sealant before installing. *NOTE: Make sure when tightening not to turn the drain "T" on the bottom of the Tank Assembly.

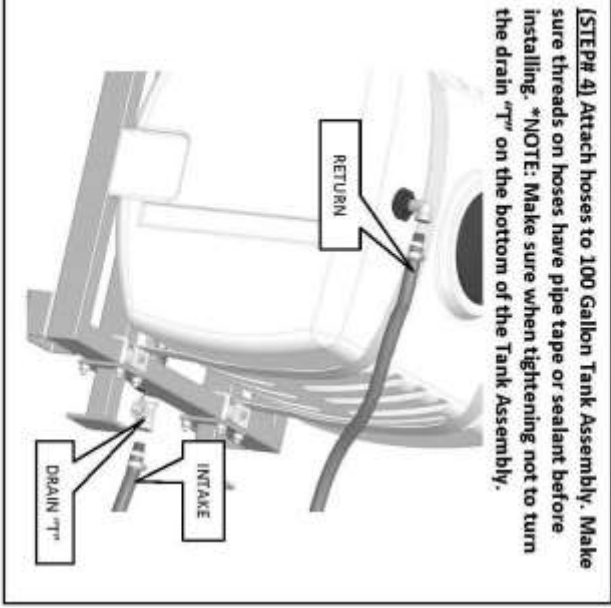

[STEP# 5] Bring Tank Assembly up to machine. Line up both sides of Assembly to Machine sides. Have Mounts on Tank Assembly up against frame on Machine. Using Hardware Included (PN 1707 & 1180), connect Tank Assembly to Machine.

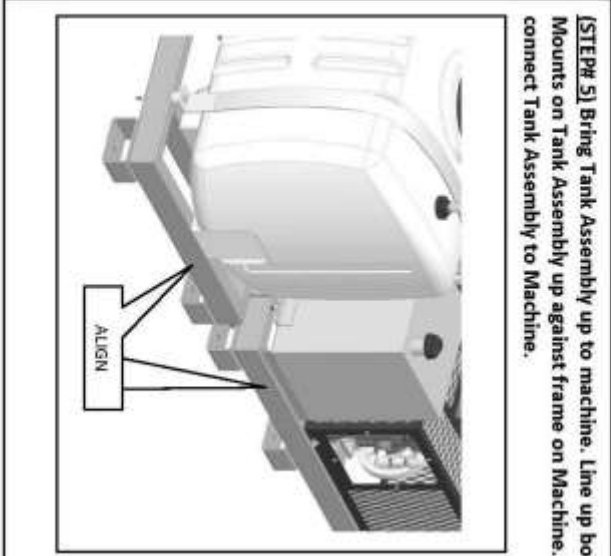
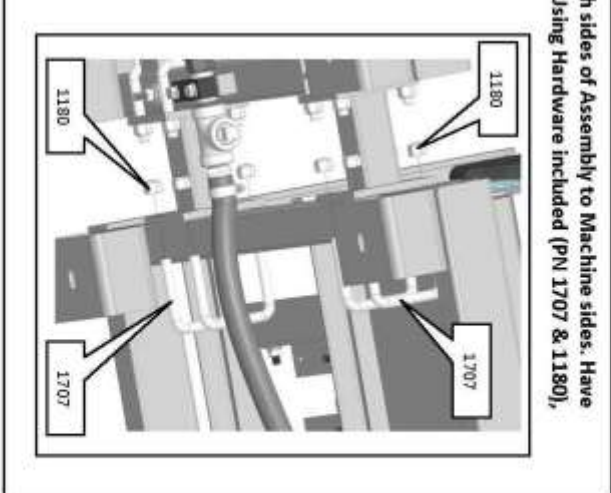
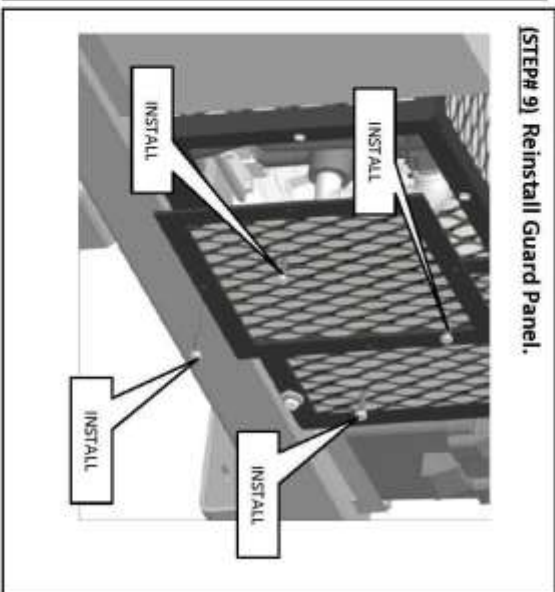
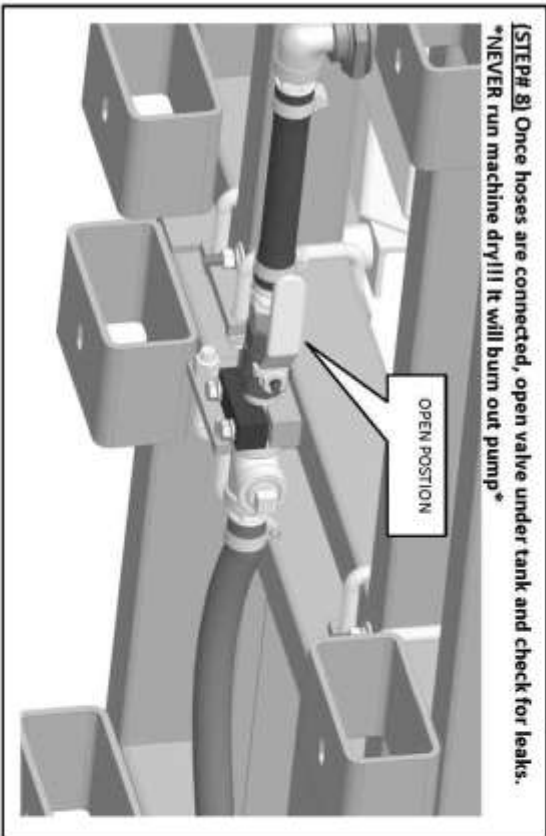
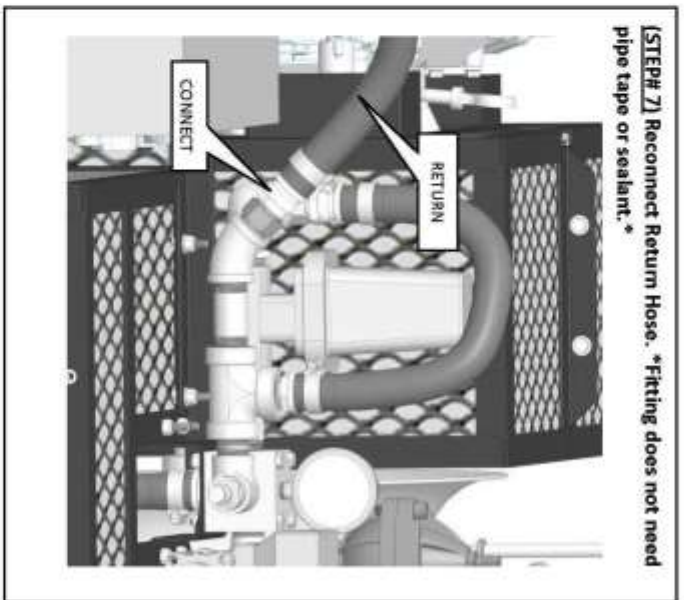
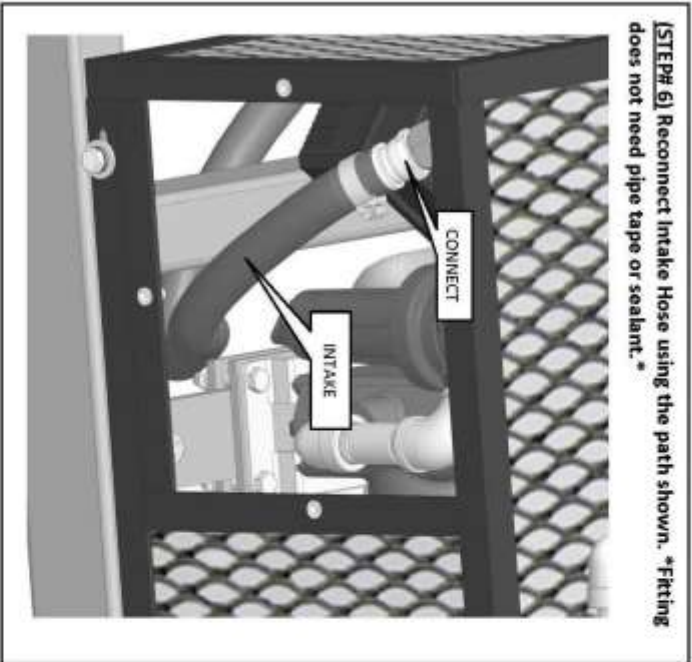

Diagram showing the hardware being used to connect the tank assembly to the machine. Callouts point to parts 1180 and 1707.



100 GALLON TANK INSTALLATION INSTRUCTIONS

100 GALLON TANK INSTALLATION INSTRUCTIONS



4.5 FIELD OPERATION

1. Do not direct monsoon towards people, pets, autos, windows, etc.
2. **Starting Sprayer and/or Granular unit:** Always start engine at a lower engine speed with nozzle pointed down or away.
3. The air stream direction is changed (in either direction) by pressing the nozzle buttons on the transmitter. The nozzle will stop turning by releasing the transmitter button. ALWAYS CHECK THE GROUND CLEARANCE WHEN OPERATING THE NOZZLE IN THE DOWN VERTICAL POSITION.
4. **Stopping Sprayer and/or Granular unit:** Shut engine off above ½ throttle by turning key switch to off position to avoid engine backfire.
5. Allow the blower fan speed to come to a complete stop before disconnecting from tow vehicle.

4.6 Operating RPM (All Models)

The manufacturer’s engine section normally recommends the unit be run at a RPM that will insure efficient operation. The Sprayer and/or Granular unit can operate at a slower RPM. Increase engine RPM as needed. Always try to blow with the wind.

4.7 Storage

At the end of each day and before storing the Sprayer and/or Granular unit, prepare the machine by following this procedure:

1. Select a storage area that is dry, level and free of debris.
2. Thoroughly wash the machine with a water hose to remove all debris and residue. DO NOT PRESSURE WASH
3. Run the machine at low RPM to dry the Blower Components.
4. Touch up all paint chips and scratches to prevent rusting.
5. Inspect for worn or failed components. Order the replacement parts and repair the monsoon unit when time allows. This will eliminate unnecessary down time at the start of next season.
6. Store in an enclosed building. If space is not available, cover with a waterproof tarpaulin and tie it down securely.
7. Store the machine away from areas of human activity.
8. Do not allow children to play around the stored unit.

5.0 TROUBLE SHOOTING

The Buffalo Turbine Sprayer and/or Granular unit uses a high volume and velocity of air to move material from one place to another. The system is simple and reliable requiring minimal maintenance. If you encounter a problem that is difficult to solve, even after reading through this trouble shooting section, please call your local dealer or distributor. **Before calling, please have this Operator’s Manual and the serial number from your Blower ready.** In the following section, we have listed causes and solutions to the problems that you may have encountered.

**TURN OFF ENGINE, REMOVE KEY, AND DISCONNECT BATTERY BEFORE SERVICING BLOWER UNITS.
INSTALL GUARDS BEFORE OPERATING**

PROBLEM	CAUSE	SOLUTION
No air flow	Buildup of debris inside turbine Broken coupling (KB Series) Blower fan not turning	Remove nozzle and clean debris from inside turbine Replace coupling
Reduced or no air flow	Blower fan turns	Air intake or exhaust restricted Shut off engine Blower or tractor – remove restrictions Debris cannot be allowed to build up between the blower fan and stationary vanes
Machine vibrates or Unusual sounds	Bearing or coupling failure Out-of-balance	Replace bearings or coupling Have your dealer check blower for damaged blades. Wash and clean blower fan blades
No Liquid Spray	Toggle switch not turned on Holding tank plugged or empty Loose or broken belt Pulleys slipping Defective or worn pump Dirty strainer or nozzle screens	Turn switch on from control panel Check hoses and fill tank Adjust or replace belts Tighten set screws on pulleys Rebuild or replace pump Clean or replace strainer/nozzle screens
Granular Bin troubles	Clutch not engaged Granulars packing solid Loose or broken belts Pulleys slipping Inconsistent application	Turn switch on from control panel Check agitators Adjust or replace belts Tighten set screws on pulleys Check and clean control gates
Belts or Pulleys overheat	Belts slipping	Adjust belt tension
Engine will not start	Dead battery Battery cables dirty or disconnected	Charge or replace battery Clean and connect terminals

6.0 Machine Specifications

Model CS4 Series

Length(without trailer): 114" with nozzle assembly & 100 gallon tank attached
Length (with DOT Trailer) 166" with nozzle assembly & 100 gallon tank attached

Width(without trailer): 38"
Width(with DOT Trailer): 80"

Height(Without trailer): 38 1/2" (with Granular bin 53")
Height(With DOT Trailer): 54" (with Granular bin 73")

Weight (without trailer): TBD
Weight (with DOT Trailer): TBD
Weight(with granular bin & 100 Gallon tank): Approx. 820 lbs.
Weight(with granular bin and DOT trailer): TBD

Electrical System: 12 Volt battery / 300 CCA

Fuel Capacity: 12 gallon Unleaded Fuel only

Input Power: ECH749 Kohler Engine (EFI does not have a choke)

Outlet Size: Approximately 12"

7.0 MAINTENANCE SECTION

7.1 Maintenance Safety

1. Set Blower on a level surface, stop engine, set park brake, remove ignition key and wait for all moving parts to stop before dismounting to service, adjust or repair.
2. Reinstall and secure all guards removed for servicing before starting to use machine again. *We recommend wearing gloves when removing or installing the guard to avoid getting cut*
3. Securely support machine with blocks or safety stands when changing tires or working beneath it.

7.2 Fluids

Change oil per Manufacturer's specification (see Engine owner's manual section).
A Teflon spray type lubricant on the nozzle base and slides provides for freer rotation.
Use only a hand-held grease gun for all greasing (USE NLGI2 grease only)

7.3 SERVICE CHECKLIST

See Lubrication and Maintenance sections for details of service. Copy this page to continue record.

TURN OFF ENGINE, REMOVE KEY & DISCONNECT BATTERY BEFORE SERVICING BLOWER UNIT

CODE: LUBRICATE-(L) / CHECK-(*) / CHANGE-(C) / REPLACE-(B) / CLEAN-(CL)

SCHEDULED MAINTENANCE HOURS _____

SERVICED BY _____

MAINTENANCE

8 hrs or daily

(*) Remove all debris that has settled between the blower wheel fan and the stationary vanes.

Helps maintain peak performance.

(*) Check engine oil and fill to proper level – Do not overfill

(*) Check air filter and precleaner

(CL) Clean debris from air intake and other cooling areas on the engine

(*) Check tire pressure (Max. 50 PSI)

(*) Check Clamp Band Bolt for tightness

40 hours or weekly

(*) Check condition of coupling (center section # 1256) connecting bolts and nuts during each oil change or when experiencing vibration or unusual noises. (See page 15)

(*) Inspect battery terminals for any corrosion, broken wires, or loose connections.

(*) Remove Battery and clean debris from inside of battery box

(L) Nozzle base slides (Teflon or silicone spray)

(*) Check set screw (nozzle pulley) to ensure it is tightened

(*) Wash and Clean any dirt or grime build up that has accumulated on blower wheel fan blades. Helps to minimize vibration balance and maintain peak performance.

100hrs or monthly

(L) Pump (Hypro 5210) grease fitting on cam bearing. With a flat tool, apply a generous dab of grease to the outer diameter surface of the cam bearing at the top and bottom, where the bearing contacts connecting rod.

(L) Granular Bin

200hrs or annually

(CL) Machine

DO NOT OPERATE SPRAYER AND/OR GRANULAR UNIT WITHOUT GUARDS SECURELY ATTACHED

7.4 Belt Tension

Efficient machine operation requires that the belts always be properly tensioned.

V-belts 6930 and 6945 are used to drive the Hypro pump (shown below).

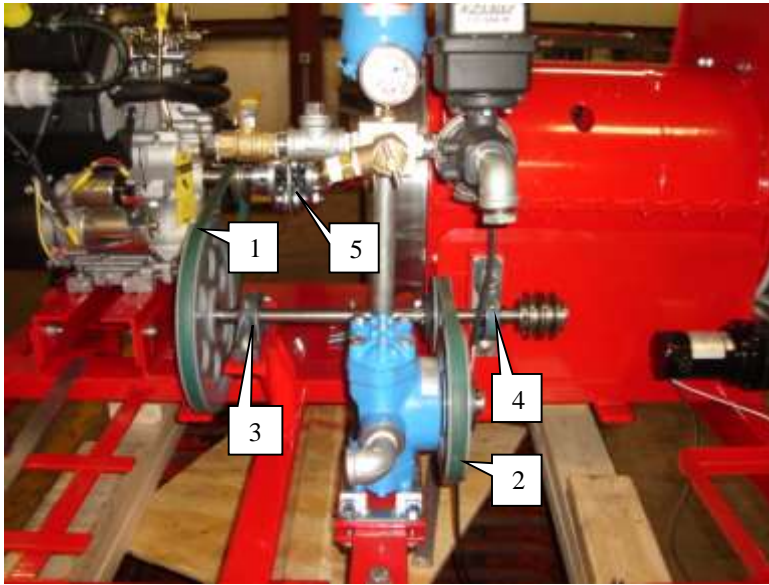

To adjust belt #1 (6945), loosen bolts on bearing #3 then move bearing in the direction of the arrow. Tighten bolts securely and check for proper tension.

To adjust belt #2 (6930), loosen pump mounting bolts at the base of the pump and move in the direction of the arrow. Tighten bolts securely and check for proper tension.

Always check the pulleys and jack shaft alignment after any adjustments are made. Replace belts that are broken, worn or stretched.

7.5 Changing the Belts

After using the Model CS4 for a long period of time, the belts will stretch and wear. To change belts, follow this procedure:

1. Turn off engine and remove key for **SAFETY**. Remove the guards around belt and pulleys.
2. Refer to the picture section 7.4 for changing the belts. To replace belt #1 (6945), loosen bearing #3 then slide the bearing toward the output shaft of the engine. The center section of the coupling (#5) will have to be removed in order to remove the old belt and install a new one. Page 28 has a detailed picture of the coupling. The center section of the coupling must be disassembled and assembled with extreme care. Damage to the coupling can result in premature bearing failure in the turbine and engine. A new bolt kit for the coupling is recommended before reassembling the coupling. **ALWAYS USE TOPLOC NUTS**. Remove the bolts from the coupling (2 ea. side of flange). Loosen setscrews on one flange only. A thread lock material is used on the threads at assembly. Heat may be needed to break that bond. Clean all dirt and rust that has accumulated on the shaft (behind the flange) then slowly wedge the center section off of the flange. Note: The flanges are counter bored to match the flange bushings. Once the center section is removed, belt #1 can be removed and a new belt can be installed. **DO NOT TENSION THE BELT UNTIL THE CENTER SECTION OF THE COUPLING IS INSTALLED**. Bolt the center section per the picture on page 28. **DO NOT TIGHTEN THE SET SCREWS AT THIS TIME**. Note position of bolts and locking nuts. Once the coupling is installed and securely tightened, check to see if the key is in position on the shaft and in the keyway of the flange. Coat the setscrews with Loc Tite (red) and securely tighten. Re check all the setscrews and coupling bolts before proceeding.
3. To replace belt #2 (6930), loosen mounting bolts (#5) under the Hypro pump and slide toward the Turbine. Remove old belt then install the new belt. Adjust the belt tension by sliding the pump assembly away from the Turbine Assembly. See section 4.2.1. in the previous section for more information. Check the pulley alignment and recheck both belts and the tightness of all bolts and set screws. **ASSEMBLE ALL GUARDS BEFORE OPERATING UNIT!**
4. To replace (4L870) Granular Bin belts (optional Granular models only) remove granular bin cover. Remove two 3/8" bolts on jackshaft right side bearing. Slide old belts off. Replace with new belts and reinstall two 3/8" bolts in pillow block, apply pressure straight down on jackshaft to give proper belt tension and tighten pillow block bolts. Reinstall guards.
5. **Install all guards before operating blower unit!**

INSTALLATION INSTRUCTIONS & PARTS FOR THE MOREFLEX COUPLING

COUPLING COMPLETE, KOHLER ENGINE

PN 1110(1pc), 3805 (1pc), 1112(4pc), 1113(4pc), 1114(1pc), 1115(1pc), 1256(1pc), 2869(4pc)

ALIGNMENT OF TURBINE SHAFT WITH SHAFT OF ENGINE IS CRITICAL

1. Install keys in both shafts.
2. Slide coupling flanges on both shafts (engine and turbine shafts)
3. Place Morflex coupling CENTER SECTION between coupling flanges and secure with 4 bolts and TOPLOC nuts. The bolt heads are positioned against the coupling in alternating directions. Tighten all 4 bolts. DO NOT TIGHTEN SET SCREWS AT THIS TIME.
4. Check key for proper position under the set screw hole on both shafts.
5. Place several drops of Loctite 271 into these two holes only. Set screws and tapped screw holes must be free of dirt and oil for Loctite to work properly.
6. Install the set screws over the keys and tighten firmly.
7. Using a drill point, dimple each shaft through the other 2 set screw holes. Clean drill chips, oil and dirt before applying Loctite.
8. Place several drops of Loctite 271 in these 2 holes.
9. Install and tighten set screws in these 2 holes.
10. Check and retighten the 4 bolts that hold the coupling center section in place.
11. Visually inspect the unit and replace the guard. DO NOT OPERATE WITHOUT THE GUARDS IN PLACE.

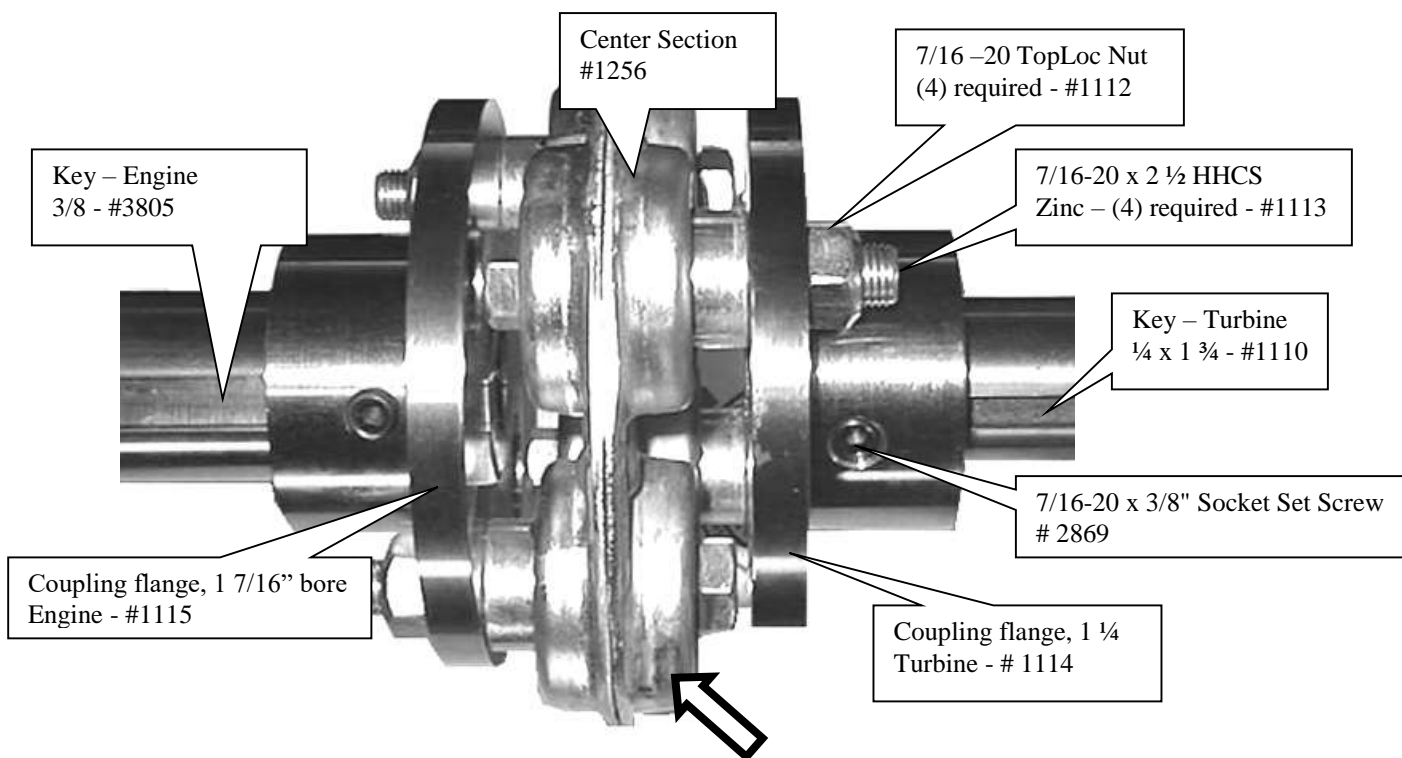

Part # 1256 (center section) is a **“WEAR”** item that should be visually checked each time the engine oil is changed. This coupling is equipped with special lock nuts. Occasionally check that all 4 nuts are securely fastened. **LOOK FOR CRACKS IN THE RUBBER COMPOSITION THAT SURROUNDS THE 4 BUSHINGS. Replace the center section when the rubber composition begins to show ANY signs of cracking OR an increase in vibration OR unusual sounds. When in doubt, call our Service Department.**

MOUNTING BLOWER ASSEMBLY ONTO FRAME **AND ALIGNMENT RECOMMENDATIONS**

1. Install blower assembly onto frame and tighten all of the bolts.
2. Remove all burrs and oil from the shafts and keyways (engine and blower shafts).
3. Using the supplied gauge, align the shafts parallel to each other (very important).
4. Check in four places around the shafts at 90° to each other.
5. When properly aligned, gauge should have little to no gap between itself and the shafts at any point along the gauge.
6. To adjust, move the engine. The 2 mounting brackets have tapped holes in each corner to help support and adjust the position of the engine. The 4 roll pins may need to be repositioned after alignment is completed and bolts are tightened.
7. Tighten all engine bolts and recheck alignment. Drill and install 4 roll pins in new position.

ACCEPTABLE

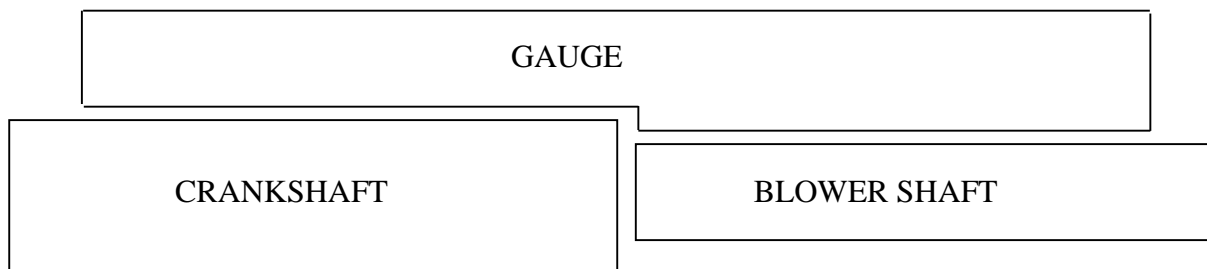

NOT ACCEPTABLE

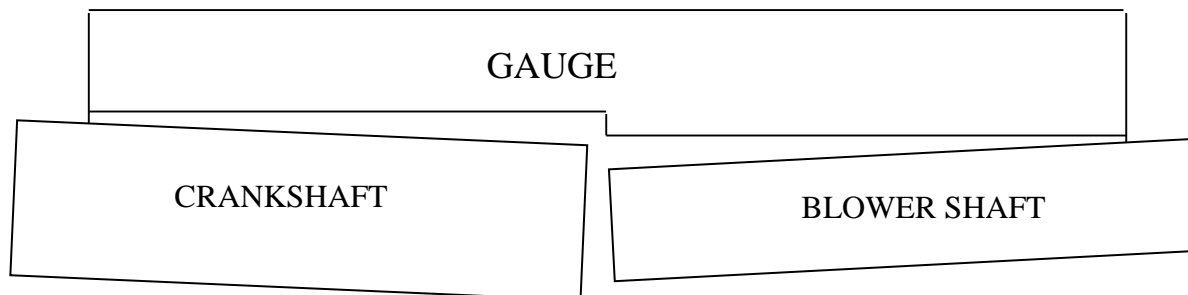

SECURELY ATTACH GUARDS BEFORE OPERATING BLOWER UNITS

BILL OF MATERIALS FOR BT-CS4G

REF PAGE #	PN	DESCRIPTION	QTY
	1100	3/8-24 X 1-1/4 HHCS ZINC GR 5	16
	1101	3/8-24 X 1-1/2 HHCS ZINC GRADE 5	7
	1102	3/8-24 X 1-3/4 HHCS ZINC GRADE 5	8
	1103	3/8-24 X 2 FACED HEAD SCREW ZINC GRADE 5	2
	1104	3/8-24 X 2 HHCS ZINC GRADE 5	9
	1105	3/8-24 HEX NUT ZINC PLATED GRADE 5	33
	1106	SPACER-3/8 X 3/16 THICK WASHER	4
	1107	3/8 LOCK WASHER ZINC PLATED	42
	1108	3/8 FLAT WASHER ZINC PLATED	46
	1109	3/16 X 1/2 ROLL PIN	4
	1110	KEY, 1/4 X 1-1/2	2
	1112	7/16-20 TOPLOC NUT GRADE 5 ZINC	4
	1113	7/16-20 X 2-1/2 HHCS ZINC GRADE 5	4
	1114	COUPLING FLANGE 1-1/4 BORE	1
	1115	COUPLING FLANGE 1-7/16 BORE	1
25	1119	14-221-D1 BELLMOUTH	1
	1123	M8 X 1.25 X 1/4 HHCS	1
22 & 25	1125	1/2-20 NYLOC NUT ZINC	19
	1130	5/16-18 X 3/8 SET SCREW	5
	1131	3/8-16 X 3/8 SET SCREW	1
	1132	300 CCA BATTERIES FOR KB'S UIL-4	1
24	1135	AK25 X 1/4 SHEAVE FOR GRANULAR BIN	2
25	1138	PLASTIC SLIDES	3
	1139	3/8 NOTCHED WASHER	10
25	1142	AX54 V-BELT	1
25	1144	ROTATION MOTOR BRACKET	1
25	1145	SHEAVE AK32 X 1/2	1
	1146	10-32 X 5/8 SHCS	4
	1156	SERIAL TAG	1
	1158	1/4" GAS LINE	56
	1166	COV 1/2 X 1/4 WIRE CLAMP	5
	1168	HC-4M SS HOSE CLAMP	5
	1169	1/4-20 X 1HHCS ZINC	25
	1170	1/4-20 HEX NUT	2
22	1173	CLAMP BAND W/ BOLT & NUT	2
	1187	8 X 10 BT DECAL	2
22	1193	1/16 X 1/2 COTTER PIN	2
22 & 25	1194	3/16 X 1-1/2 COTTER PIN	2
	1218	BOLT, 1/2 PUSHOVER	1
22	1222	1/2 LOCK WASHER ZINC	4
	1223	1 X 1/2 X 3/16 THICK WASHER	2
	1226	1/2 FLAT WASHER	3
22	1231	1/2-13 HEX NUT	2
	1236	3/16 X 1 ROLL PIN	1
	1237	1/2-20 HEX NUT	2
25	1239	FRAME, CSII SPRAYER	1
24	1247	1/4 PILLOW BLOCK BEARING	2
	1256	MOREFLEX CENTER SECTION	1
	1258	1/4-20 X 1/4 HHCS	4
	1259	1/4 LOCKWASHER	7
	1271	5-16-18 HEX NYLOC NUT	2
	1272	5/16-18 JAM NUT	3
24	1291	A-81 V-BELT	2
25	1308	PUMP MOUNT PLATE FOR CSII	1
25	1315	PUMP MOUNT PUSHOVER PLATE	1
26	1356	DUST FEED WIRE SCREW, LONG	3
25	1359	ENGINE RAIL	2
22	1409	LINEAR ACTUATOR - 4" STROKE	1
22 & 25	1414	REMOTE THROTTLE PIN	2
	1415	1/2" FLAT WASHER	28
22	1451	ACTUATOR MOUNT, PIN	1
26	1464	DUST AGITATOR	9
24	1487	MANIFOLD BLOCK, ALUMINUM	1
	1499	NUT PLATE, 3/8	4
25	1510	PUMP MOUNT BAR FOR CSII	1
26	1519	DUST FEED STUD, VERTICAL	3
24	1520	HYPRO PUMP 5210C	1
24	1521	1/2" PRESSURE RELIEF VALVE	1
23 & 24	1522	HYPRO SURGE TANK	1
23 & 24	1523	0-300 PSI PRESSURE GAUGE	1
	1540	5/16 LOCK WASHER, ZINC	16
	1541	5/16 FLAT WASHER	6
25	1542	LINEAR ACTUATOR - 2" STROKE	1
24	1555	SHEAVE, BK 100H	1
	1558	807-31 1/2" FEMALE COUPLAMATIC HOSE END	1
	1559	3/4" MALE PUSH ON FITTING	3
23	1560	3/4" FEMALE PUSH ON SWIVEL FITTING	5
24	1562	SHEAVE, BK40 H	1
24	1563	H 3/4" BUSHING	2
26	1568	5/8" SHAFT COLLAR, GRANULAR	4
26	1577	5/8" PILLOW BLOCK BEARING VPS 210	3
26	1578	GEAR BLANK FOR GRANULAR GEAR	3

REF PAGE #	PN	DESCRIPTION	QTY
26	1579	WORM TO FIT 1578	3
24	1586	PULLEY, 3-3/8 X .850 WIDE	1
24	1589	6945 GATES V-BELT	1
23	1593	3/4" BRASS HEX NIPPLE	5
	1596	3/16 SQUARE X 1-3/8 KEY	5
	1597	ALUMINUM SPACER 3/8 X 1-1/2 X 5.1	1
	1599	1/2-20 X 1-3/4 HHCS ZINC GR 5	2
26	1610	5/32" x 7/8" SPRING PIN	3
26	1644	DUST FEED SHAFT, HORIZONTAL	1
24	1648	H X 1" BUSHING	1
	1664	5/16-24 X 1 1/4" HEX HEAD BOLT GRADE 5, ZINC PLATED	11
	1669	1/4-20 X .055 HEAD INSERT	15
26	1696	DUST FEED SHAFT, VERTICAL	3
	1720	1/2" GOODYEAR ORTAC HOSE	60
	1727	PUMP PUSHOVER BOLT FOR CSII	1
	1732	1/2" GOODYEAR ORTAC HOSE	111
	1762	10-24 X 1/2" THREAD FORMING SCREW PHILLIPS PAN HEAD	7
25	1767	LATCH AND CATCH, GRANULAR	1
	1820	5/16-18 X 3/4" LONG HHCS	2
22	1825	PUMP GUARD ACCESS PANEL	1
26	1851	DUST FEED TUBE LONG	2
26	1852	DUST FEED TUBE SHORT	1
26	1896	DUST FEED AUGER	3
26	1922	DUST FEED CONE	3
23	1935	3/8-24 NYLOC NUT ZINC PLATED	6
25	1982	GRANULAR BIN FOR GRANULAR SPRAYER	1
25	1983	DUST BIN MOUNT, FRONT	1
25	1984	DUST BIN MOUNT, REAR	1
22	1985	SQUARE PUMP GUARD	1
26	1986	DUST FEED CHANNEL, GRANULAR SPRAYER	1
25	1987	DUST FEED CHANNEL COVER	1
	2076	INSULATED FEMALE QUICK DISCONNECT TERMINAL	2
26	2210	DUST FEED GATE, STAINLESS	3
26	2211	DUST FEED GATE FLANGE	3
25	2212	GRANULAR BIN GAGE BAR	1
25	2213	GUAGE BAR POINTER, GRANULAR BIN	1
26	2214	WARNER ELECTRIC CLUTCH, SF400-5/8-12V	1
26	2216	DOUBLE CLUTCH PULLEY	1
26	2218	DUST FEED BUSHING, BRONZE	3
26	2219	SPACER, VERTICAL DUSTER SHAFT	3
25	2220	GATE CONNECTING BAR, GRANULAR	1
22	2221	VERTICAL BELT GUARD, GRANULAR	1
24	2222	JACK SHAFT, GRANULAR	1
25	2223	ACTUATOR MOUNT, GRANULAR	1
25	2224	HANDLE FOR DUSTER BIN	1
	2225	1/4-20 X 1/4" LONG SOCKET HEAD SET SCREW	7
	2226	5/16-24 X 3 1/4" LONG HEX HEAD CAP SCREW, GRADE 5, ZINC PLATED	4
26	2228	1/4-20 X 3/4" LONG SET SCREW, SQUARE HEAD	15
26	2233	3/16 X 1 -1/4" LONG ROLL PIN	3
	2306	8-32 X 7/8" LONG PHILLIPS	6
	2329	8-32 NYLOC NUT, ZINC	6
	2395	1/2" MALE VARI CRIMP COUPLING	1
	2675	3/4" STREET "L" 304 STAINLESS	2
	2677	3/4" BRASS HOSE ADAPTER	1
	2693	KEY, 5/16 X 1 1/2"	1
22	2851	PLASTIC NOZZLE	2
	2869	7/16-20 X 3/8" SOCKET SET SCREW	4
	3007	CONSTANT TENSION HOSE CLAMP	1
22	3308	3/4" HEAVY DUTY BULKHEAD	1
	3312	3/8-24 THREADED BASE STOP	1
25	3313	ELBOW BASE W/ 2 TABS WELDED	1
25	5401	BLOWER ASSEMBLY KB WITH 3 HOLES	1
22	3332	3/16" ID FUEL LINE,SAE30R7, LOW PERMATION, CARB APPROVED HOSE	43
	3514	HOSE CLAMP	8
	3521	3/8-24 X 1-1/2 FACED HEAD SCREW	2
	3667	HOUR METER, 1:2 RATIO	1
22	3733	LEFT SIDE EFI GUARD	1
	3802	1/4-20 X 2-3/4" LG HHCS	4
24	3803	BK90H SHEAVE	1
24	3804	6934 V-BELT	1
	3805	3/8 KEY, SPRAYER/GRANULAR	1
23	3806	DISTRIBUTION BLOCK BRACKET	1
22	4136	SPRAYER NOZZLE WELDMENT	1
22	4137	12 GALLON ALUMINUM TANK	1
24	4154	3/4" X 3/4" "T" STRAINER W/50 MESH SS SCREEN	1
22	4155	SPRAY TIP NOZZLE, TXR CONEJET, LIGHT BLUE ACETAL-CERAMIC HOLLOW CONE	8
22	4156	SPRAY TIP CAP	8
22	4157	STRAINER/CHECK VALVE 50 MESH	8
22	4158	1/4" MALE THREADED ADAPTER	8
24	4159	3-WAY SHUTOFF VALVE	1
22	4160	SPRAYER TRANSITION GUARD	1
22	4167	BULKHEAD MOUNT	1

REF PAGE #	PN	DESCRIPTION	QTY
22	4168	MOUNT PLATE	1
	4170	BT SMARTFLOW II CONTROLLER W/BT-RESM & BT-TAM	1
23	4172	3/4" X 1/2" REDUCING BUSHING, STAINLESS STEEL	1
	4173	3/4" ELBOW, STAINLESS STEEL	1
23	4175	3/4" CLOSE NIPPLE, STAINLESS STEEL	3
23	4176	1/2" STREET ELL, STAINLESS STEEL	2
23	4177	3/4" X 3" NIPPLE, STAINLESS STEEL	4
23	4178	1/2" X 1-1/2" NIPPLE, STAINLESS STEEL	1
23	4179	3/4" 45 DEGREE ELBOW, STAINLESS STEEL	2
22	4180	LED LIGHT STRIP ASSEMBLY	1
25	4181	ROTATION MOTOR W/ WEATHER PACK CONNECTOR	1
25	4185	EFI ENGINE, STOCK MODEL	1
	4187	GARDEN HOSE COUPLING SET, QUICK DISCONNECT BRASS WITH 3/4" THREAD	1
22	4188	1/2" TO 1/4" STRAIGHT REDUCER WITH SEALANT, BRASS NPT THREADS	1
22	4189	3/4" NPT X 1/2" ID HOSE BARB FITTING BANJO# HB 075-050	1
24	4190	3/4" NPT X 1/2" ID HOSE BARB FITTING BANJO# HB 075-050-90	1
	4191	1/2" ID GREEN HOSE 600 PSI PVC SPRAY REINFORCED HOSE, .79" OD	41
	4192	1/4" FLAT WASHER, 18-8 STAINLESS STEEL	12
	4193	1/4-20 X 3/4" LONG HEX DRIVE ROUND HEAD SCREW, STAINLESS STEEL	6
	4194	1/4-20 NYLOC NUT, 18-8 STAINLESS STEEL	6
22	4195	PRESSURE SWITCH SET AT 1.8" H2O	1
23	4196	3/4" PLUG, STAINLESS STEEL	2
	4204	CONTROL BOX ASSEMBLY, 2 SWITCH, GRANULAR BIN	1
22	4205	GRANULAR BIN BATTERY BOX ASSEMBLY	1
	4208	PLUG BUTTON	1
	4209	PLUG: KEY SWITCH	1
25	4210	MUFFLER KIT, EFI, FILTER SIDE/STRAIGHT	1
22	3294	100 GALLON TANK ASSEMBLY	1
22	4211	BRASS BARBED HOSE ELBOW, 90 DEGREE ANGLE, 1/4" HOSE ID, 1/4 NPT MALE END	1
22	4212	BRASS BARBED HOSE ELBOW, 90 DEGREE ANGLE, 3/8" HOSE ID, 1/4 NPT MALE END	1
22	4213	HIGH-PRESSURE BRASS THROUGH-WALL ADAPTER, 1/4 NPT FEMALE X MALE	1
22	4240	TEEJET ADAPTER, ELBOW	8
22	4241	TEEJET ADAPTER, EXTENSION	8
23	4242	SPACER	2
23	4245	MOUNT PLATE WELDMENT	2
	4246	3/16" VINYL COATED LOOP CLAMP	1
23	4247	3/8" NPT 304 STAINLESS STRAIGHT CONNECTOR 1-1/2" LONG	1
23	3293	STEEL PIPE CLAMP	4

BT-CS4G PARTS REFERENCE

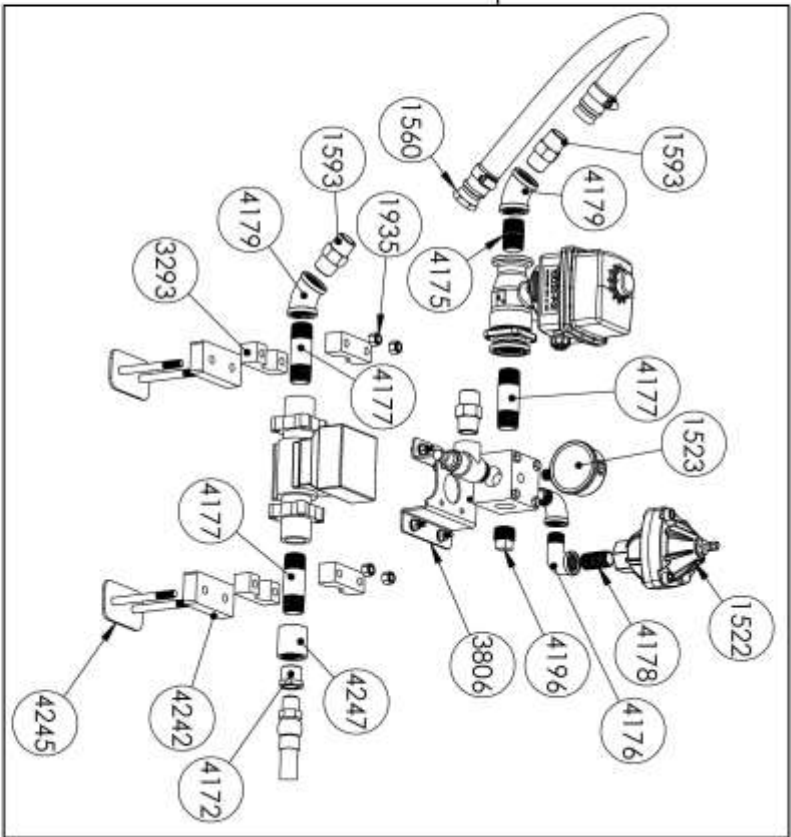
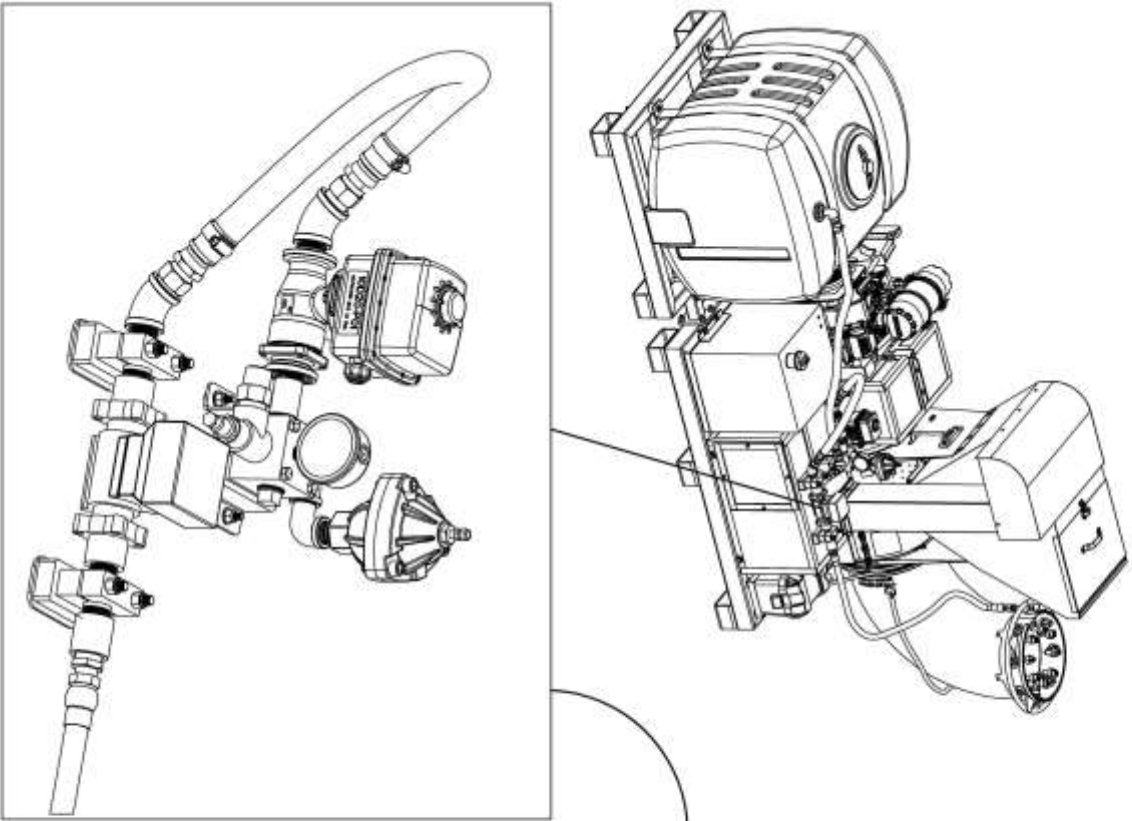

BT-CS4G PARTS REFERENCE

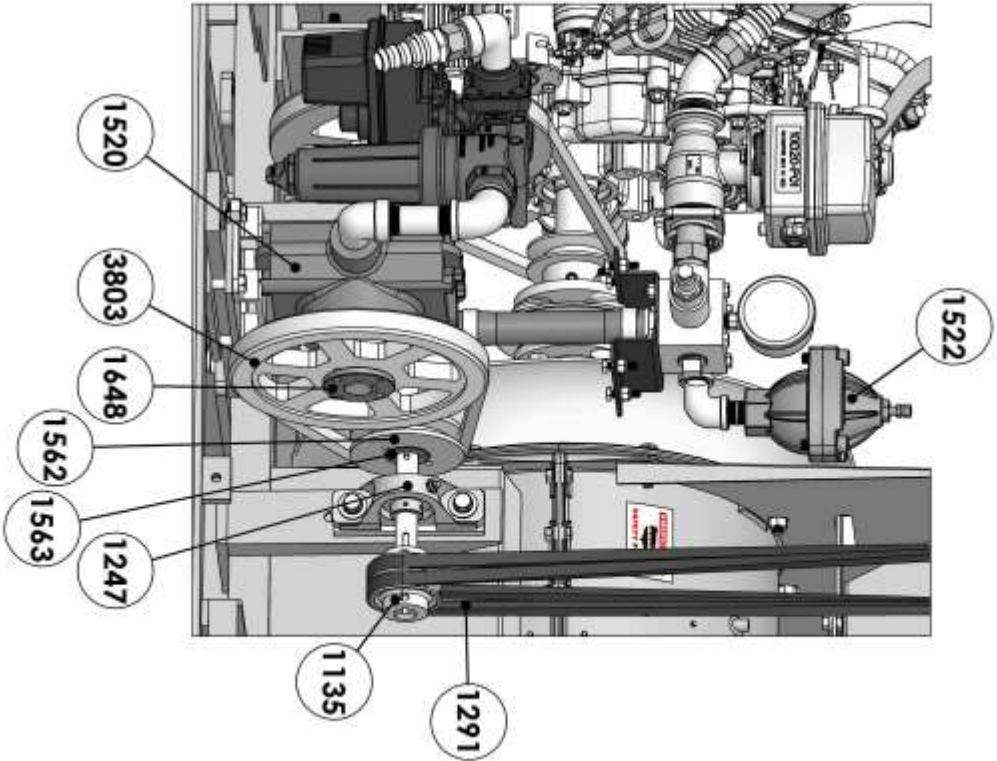
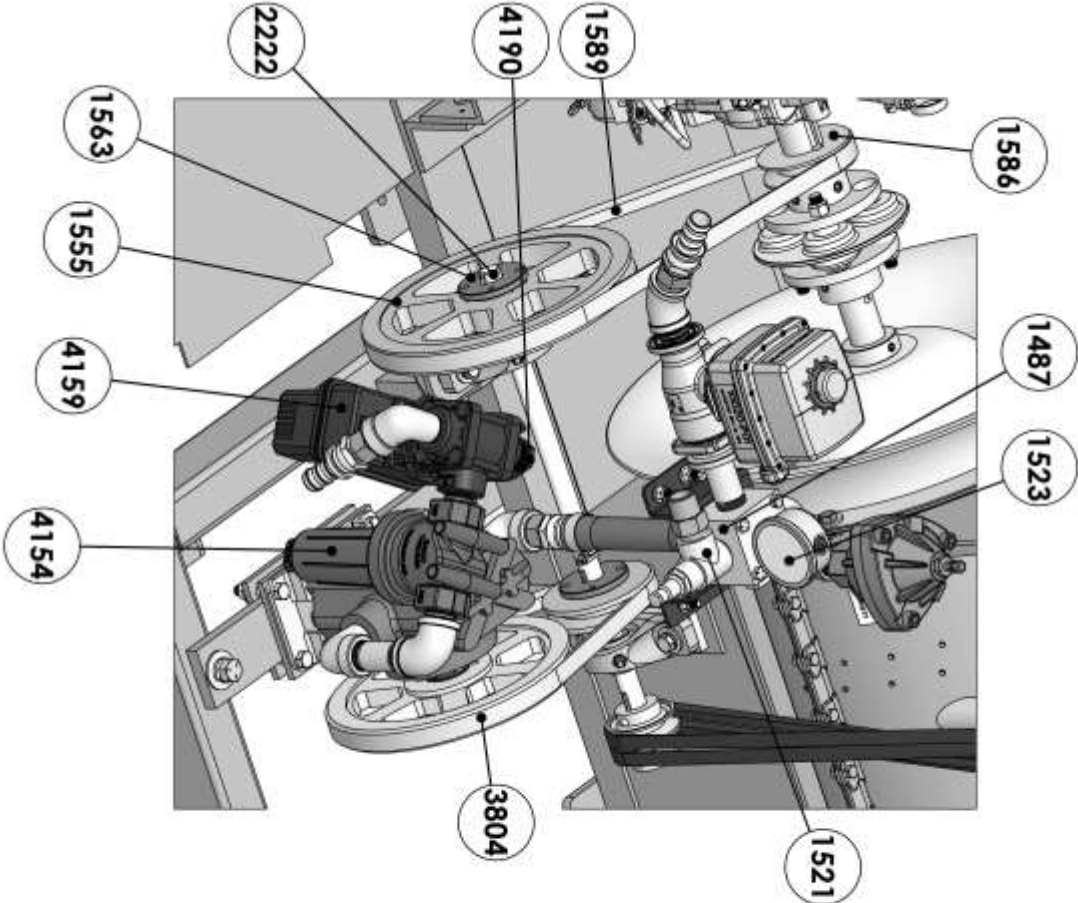

BT-CS4G PARTS REFERENCE

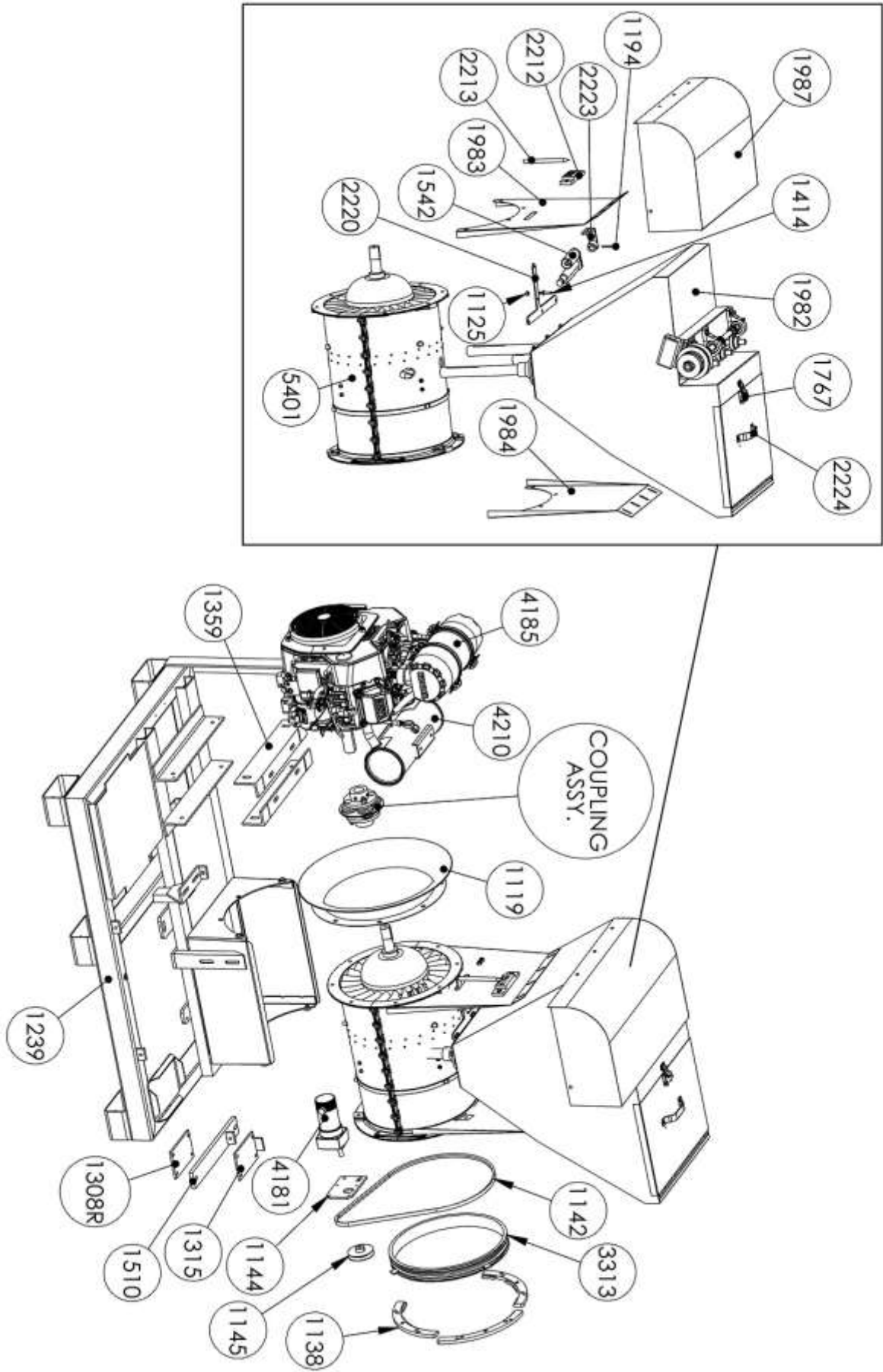

BT-CS4G PARTS REFERENCE

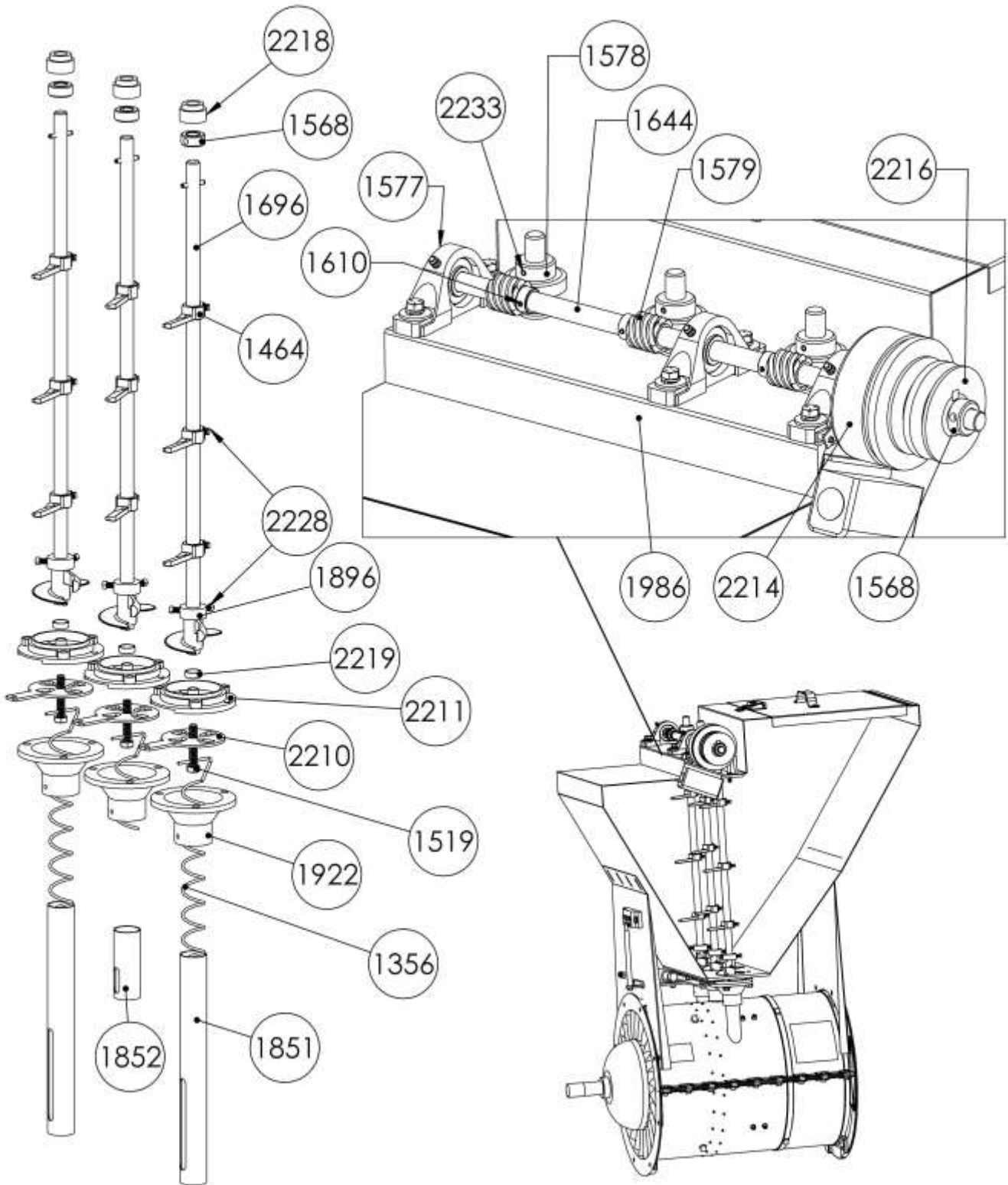

GRANULAR BIN DISASSEMBLY AND ASSEMBLY INSTRUCTIONS

1. Remove the (5) bolts on cover and remove cover.
2. Remove the (4) bolts and nuts on front and rear dustbin mounts.
3. Remove dustbin gate lever.
4. Remove belts from dust -bin clutch and lift dust- bin out of mounting.
5. After removing dust -bin from the sprayer, set dust- bin on a stand with dust- bin tubes pointing up.
6. Remove the (3) bolts on each dust –bin dust -cone assembly and lift off cones and tubes. Check tubes for wear and replace by loosening (2) setscrews in the neck of the cone. Make sure tube slots are at right angles of the air -flow when replaced.
7. Remove the dust twist springs by sliding sideways from holes on dust twist feed stud. Remove dust -twist feed studs and dust- gates.
8. The dust feed flange must remain in bottom of dust- bin. Use bolts to remove and bolt flange in place.
9. Turn dustbin bottom side down.
10. To remove dust clutch, loosen set -screw on collar next to clutch cam. Drive out spring pins and remove. Next remove ¼ x 1 Allen head screws from throw-out shaft and bronze shaft collar and remove shaft collar. Loosen set -screw on tandem plate cover and slide clutch from horizontal shaft. Check drive plates on clutch and replace as needed.
11. Loosen set-screws on pillow block bearings
12. Drive spring- pins from gears and shaft and remove gears. Check gears for wear and replace as needed.
13. Remove bolts from (2) end pillow block bearings and lift dust- bin channel from shafts. Check bronze bushings in channel and replace as needed.
14. Check vertical shafts for wear. Replace as needed.
15. Reverse procedures to re-assemble.
16. For lubrication, see general instructions for operation.

LUBRICATION

Granular Bin Bearings Lubrication

Use Grade NLGI #2 lithium grease.

Grease every 25 hours

Granular Bin Gears

Open gear Hi-Low gear lubrication NLGI # 3

Grease every 25 hours

Unit

Multi purpose grease

Grease every 25 hours

Blower

Sealed bearing, no lubrication required

Pump

Use Grade NLGI #2 Lithium grease. See pump instruction sheet.

Engine oil. Refer to engine manual.



Installation, Operation, Repair and Parts Manual

Description



SERIES 5200C

Cast Iron Big Twin Piston Pump

Max. Flow Rate:	8 gpm (5206) @ 800 rpm
	10 gpm (5210)
Max. Pressure:	400 psi
Max. Speed:	800 rpm (5206)
	600 rpm (5210)
Ports:	3/4" NPT inlet
	3/4" NPT outlet
Shaft:	1" solid
	1-3/8" hollow shaft

The Hypro Series 5200 Big Twin® piston pump is suitable for applications in high pressure washers for industrial and agricultural cleaning needs. It is also useful as a sprayer pump to apply a wide range of chemicals.

The Series 5200 is constructed of cast iron body and cylinder heads, unitized stainless steel valve assemblies and double row ball bearing supported crankshaft. Three cup materials are available to meet specific pumping needs. They are:

Leather—for pumping aromatic solvents and other chemicals damaging to rubber.

Fabric—for pumping most insecticides, herbicides and fertilizers.

Buna-N Rubber—for pumping soap and detergent solutions and some fertilizers.

Two crankshaft options are available—1" solid shaft for belt and pulley or flexible coupling drive, or 1-3/8" hollow shaft for direct mounting onto a 6-spline 540 rpm PTO shaft.

! Safety Information

- Warning: Do not pump flammable or explosive fluids such as gasoline, fuel oil, kerosene, etc. Do not use in explosive atmospheres. The pump should be used only with liquids compatible with the pump component materials. Failure to follow this warning can result in personal injury and/or property damage and will void the product warranty.**
- Be sure all exposed moving parts such as shafts, couplers and adapters are properly shielded or guarded and that all coupling devices are securely attached before applying power.
- Pumps mounted directly on to PTO shaft or other power shaft must be prevented from rotating with the power shaft by use of a torque arm. Pump must float freely on the power shaft and must not be tied rigidly to equipment on which it is mounted.
- Do Not Exceed** recommended speed, pressure and temperature for pump and equipment being used.
- Before Servicing**, disconnect all power, make sure all pressure in the system is relieved, drain all liquids from the system and flush.
- Secure the discharge lines before starting the pump. An unsecured line may whip, causing personal injury and/or property damage.
- Check hose for weak or worn condition before each use. Make certain that all connections are tight and secure.
- Periodically inspect the pump and the system components. Perform routine maintenance as required (see Maintenance section).
- Protect pump from freezing conditions by draining liquid and pumping rust inhibiting antifreeze solution through the system, coating the pump interior.
- Use only pipe, hose and fittings rated for the maximum psi rating of the pump.
- Do not use these pumps for pumping water or other liquids for human or animal consumption.

Drive Source Installation

This manual will cover the installation of the basic drive configurations available for the Hypro Big Twin Piston pumps. Consult the manufacturer of your motor or engine

for additional information. Read all instructions and general safety information before attempting to install or operate the pump.

Belt/Pulley Drive Installation

Mounting Belts and Pulleys

Mount pulleys as close to pump and motor engine shaft bearings as possible. Check alignment with a straight edge as shown in Fig. 1. Make sure that belt has proper tension. (Too much tension will cause bearing wear; too little will cause slippage.) See Fig. 2. Check with belt and pulley sources for specific recommendation.

To figure proper diameter of pump pulley, multiply the motor/engine rpm by the diameter of the motor/engine pulley and divide that figure by desired pump speed.

$$\text{Pump Pulley Size} = \frac{\text{Motor RPM} \times \text{Motor Pulley Size}}{\text{Desired Pump Speed}}$$

Refer to the pump performance chart on Page 5 to determine the desired speed to obtain the desired maximum flow.

NOTE: Shaft rotation can be either clockwise or counter clockwise.

Four points of contact indicate alignment.

NOTE: Pump may be mounted in other orientations with respect to the motor or engine.

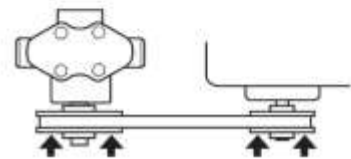

Figure 1

Push the belt midway between the pulleys, check the deflection (d) and adjust:

$$d = 0.016 \times L$$

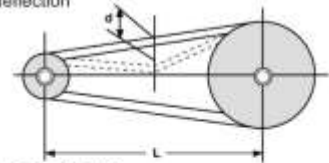

Figure 2

▲ Caution:
For safety, always install a shield over rotating shafts and belts.

Direct Drive - Flexible Coupling Installation

First, slide coupling ends onto motor/engine and pump shafts as far as possible (Fig 3). Mount motor/engine and pump onto base, shimming pump or power unit so that shafts are aligned. Leave enough space between ends of shafts to allow coupling disc to be inserted. When alignment is made, slide coupling ends over coupling disc. Leave clearance between coupling ends and center disc. Tighten screws in both coupling ends. For electric motor drive, use couplings rated at least twice the horsepower required to operate pump. For gas engine drive, select couplings rated at three times the required pump horsepower.

▲ Caution:
For safety, always install a shield over rotating shafts and couplings.

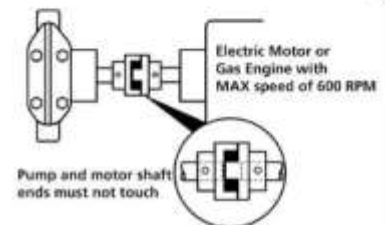

Figure 3

Direct Drive - Hollow Shaft Installation

Hollow shaft models may be mounted directly onto power shaft — motor or engine shaft, truck or tractor PTO shaft. **Important:** When direct mounting a hollow shaft pump, **Do Not** rigidly mount the pump base. The pump must be allowed to "float". Secure a torque arm with a chain or flexible fastener to the frame or base, directly below and in-line with the pump. This prevents the pump from rotating with the shaft. Always check to see if the pump will turn by hand to ensure that the pump rotates freely. **Do Not** apply power to a pump where the shaft doesn't rotate freely.

▲ Caution:
For safety, always install a shield over rotating shafts and couplings.

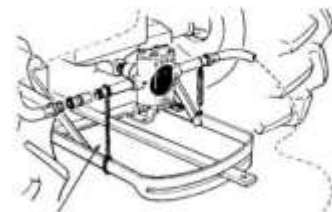
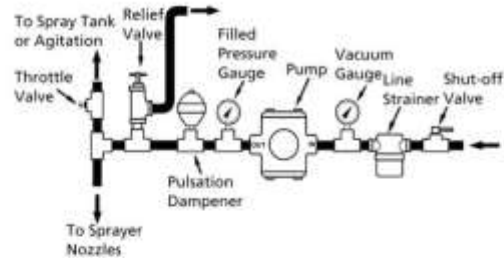

Figure 4

System Installation

Series 5200 Pump Hookup to Boom for Chemical Spraying



Note: A pulsation dampener such as our Model No. 3375-0017 or 3375-0015 must be installed on the outlet side for optimum performance and maximum life. For the proper operation of some unloader valves, it may be necessary to install a pulsation dampener downstream from the unloader valve; however, for optimum system dampening, it may be installed upstream from the unloader valve provided that the unloader valve will still function properly.

Figure 5

Series 5200 Pump Hookup for Pressure Washing

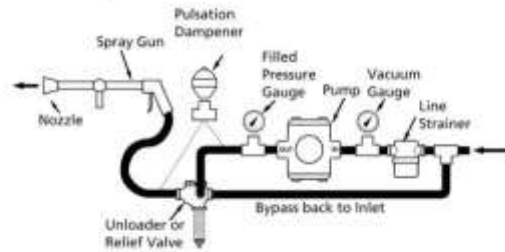

Piston Pump Installation

Accessories should be installed with solid piping and be mounted as close to the pump as possible. Hose must be used right after accessories. **Note:** If remaining installation is solid piping, a two to four foot length of hose must be installed between accessories and solid piping.

Hose

Selection of the right size and type of hose is vital to good performance. Be sure to hook up to proper ports on pump (note markings "IN" and "OUT" on pump castings).

Suction Hose

Always use genuine suction hose of at least the same inside diameter as pump ports. Hose should have some elasticity, but not overly soft so that it collapses. Use 3/4" (ID) hose or larger for a Series 5200 pump. If suction hose is over 6 feet long on Series 5200 use next larger size hose. Keep suction hose as short as possible and restrictions such as elbows, check valves, etc. at a minimum.

Discharge Hose

High pressure pumps require the use of special high pressure discharge hose (2 rayon braid or equivalent). Use a hose rated at least 50% greater than the highest operating pressure required of pump. Example: If required pump pressure is 200 psi, use discharge hose rated at minimum of 300 psi working pressure.

Unloader or Relief Valve

The unloader or relief valve has a very important safety function in your piston pump hook-up. The valve protects the pump by unloading or bypassing the pump's flow when gun is shut off or discharge is otherwise blocked.

Strainers

Use a suction line strainer with an open screen area of at least 3 to 5 times the suction port area. For example, an area of approximately 2-1/3 to 4 square inches for a 1" suction port. Be sure the screen is suitable for the liquid being pumped. Keep filter clean. A clogged strainer will cause cavitation, which usually leads to a poor performance, wear and failure of pump parts.

Vacuum Gauge (Optional)

Pump should not be subjected to high suction line vacuums. To check on this, install a vacuum gauge at pump inlet. Generally, it should not read over 5 inches of mercury.

Suction Line Shut-Off

This suction line accessory allows the pump to be removed for service without draining the tank. Be sure valve is open before starting pump.

Pulsation Dampener

A Series 3375-0015 pulsation dampener is recommended for all models. This device absorbs the shock and smooths out the pump discharge pulsations, providing smoother operation. A charge of 50% of operating pressure is normally optimum.

Pressure Gauge/Dampener

Use gauge capable of reading double the pump working pressure. Use a filled gauge or a gauge dampener to protect the gauge needle against pressure surges to provide easier reading and longer life.

Spray Gun

Use a Model No. 3381-0010 spray gun or a 3381-0013 Turbo 400 spray gun with the correct nozzle. For 5206 models, use a 3385-3000 nozzle and for the 5210 models use a 3385-4000 to obtain a maximum pressure of 400 psi.

Operation

Priming

If liquid is below level of pump, some means should be provided in installation to prime pump - such as a riser pipe. If there is a suction lift, use a foot valve or check valve to hold prime. In general, keep suction lift to minimum and avoid unnecessary bends in suction line. Before starting pump, make sure air bleeder valve or spray gun is open - or unloader/relief valve is adjusted to its lowest pressure. After starting pump, open and close gun several times if necessary to aid priming the pump. If pump does not prime within a few seconds, stop motor and inspect installation for suction line leaks or obstructions. Make sure that strainer is not clogged. Be sure that suction line is not obstructed, kinked or blocked.

If pump is to operate hours at a time, check frequently for:

1. Adequate liquid supply. Pump must not run dry for more than 30 seconds.
2. Temperature rise. Overheating is harmful to bearings and piston cups.

Care of Pump

Your pump will last longer and give best performance when properly taken care of. Proper pump care depends a lot on the liquid being pumped and when the pump will be used again.

Generally, after each use, flush pump with a neutralizing solution for the liquid just pumped. Follow with a clear water rinse. This is especially important for corrosive chemicals. Then flush out pump with a 50% solution of automotive radiator anti-freeze (ethylene glycol-type such as Prestone, Zerex, etc.) containing a rust inhibitor.

While this flushing is not absolutely necessary for short periods of idleness (as over night) it is good practice to clean the pump after each use to prevent deposits from forming and damaging the pump. The antifreeze not only coats the interior of the pump with an inhibitor, but acts as a lubricant as well, keeping the valves from sticking and protecting against any remaining moisture freezing in cold weather.

For infrequent use and before long periods of storage, drain pump thoroughly. Open any drain plugs, remove suction hose from liquid and run pump "dry" from 0 to 30 seconds (not longer). Flush with a 50% solution of anti-freeze and water. Then, plug both ports to keep out air until pump is used again.

Lubrication

Use a small push-type grease gun to lubricate Hypro Series 5200 Piston Pumps. **Do not use airpowered or hand lever operated grease guns** as they develop too much pressure and may cause damage to the sealed cam bearing. Lubricate a minimum every 100 hours or when bearing appears to need grease. Use Moly-Lithium No. 2 wheel bearing grease.

Exception: In applications where FDA approval is required, use one of these greases: Chevron FM#2, Mobile FM#2 Keystone (Penwalt Corp.) Nevastane SP Medium.

Do not under-grease or premature bearing failure may result.

Do not grease excessively. Remove (do not **WASH** out) any excess grease from pump cavity to prevent grease buildup.

Repair Instructions

Recommended Repair Tools For Hypro Big Twin Piston Pumps

Ref.	Description	Part No.
A	Internal External Pliers (not shown)	3010-0084
B	Valve Seat Extractor	3010-0130
C	Valve Cage Extractor	3010-0052
D	Wire Brush	3010-0066
E	Wire Brush Holder	3010-0067
F	Allen Wrench	3020-0009
G	Allen Wrench	3020-0008
H	Sleeve Extractor	3010-0064
	Tool Box (not shown)	3010-0168

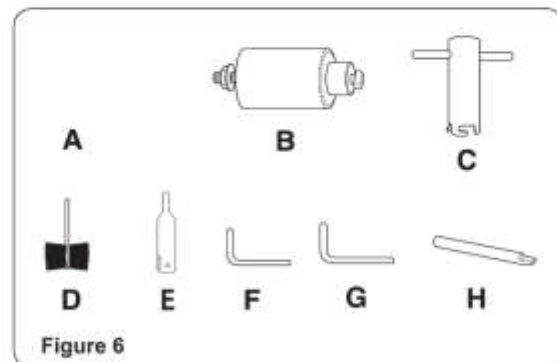

Model 5206C Performance											
	25 PSI			100 PSI			300 PSI			400 PSI	
RPM	GPM	HP	GPM	HP	GPM	HP	GPM	HP	GPM	HP	
400	3.9	.26	3.9	.40	4.0	.66	3.9	.89	3.9	1.1	
500	4.9	.29	5.0	.46	5.0	.75	5.0	1.1	4.9	1.4	
540	5.4	.31	5.4	.50	5.4	.81	5.3	1.2	5.3	1.5	
600	6.0	.34	6.0	.58	6.0	.90	5.9	1.3	5.9	1.6	
700	7.0	.40	7.0	.65	6.9	1.1	6.9	1.5	6.9	1.9	
800	8.0	.46	7.9	.74	7.8	1.2	7.7	1.7	7.7	2.2	

Model 5210C Performance													
	25 PSI			100 PSI			200 PSI			300 PSI		400 PSI	
RPM	GPM	HP	GPM	HP	GPM	HP	GPM	HP	GPM	HP	GPM	HP	
400	7.3	.39	7.3	.69	7.2	1.2	7.2	1.7	7.2	2.1			
500	8.9	.57	8.9	.87	8.8	1.5	8.8	2.0	8.7	2.6			
540	9.4	.66	9.4	.94	9.3	1.6	9.3	2.2	9.2	2.7			
600	10.0	.73	9.9	1.10	9.9	1.7	9.8	2.3	9.8	3.0			

Disassembly

1. Remove nameplate and both cylinder heads with a 9/16" combination wrench or socket.
2. Remove both piston cap screws with 1/4" allen wrench.
3. Remove piston cup spreader seal ring with O-ring piston guide and support ring.
4. Place the body into a vise as shown in Fig. 7. With care, drive out the cylinder sleeves using the sleeve extractor tool and a hammer.
5. Remove connecting rod.

Figure 7



Figure 8



6. Remove the four valves, using the valve seat extractor to pry out the seat (See Fig. 8). Use a valve cage extractor tool to remove each spring retainer. Lift out the other parts, using penetrating oil as necessary to loosen parts.
7. Place the pump body onto an arbor press with the shaft end of the pump up. Press the crankshaft and bearing out of the pump body (See Fig. 9). The main bearing will come out with the crankshaft.
8. Sand the body ends and cylinder heads (mating surfaces) lightly to remove all foreign material. Use a belt sander, flat sanding block or flat file.
9. With wire brush mounted in an electric drill, clean all valve cavities, sleeve cavities and ports. Wash pump body out with solvent and let dry.

Inspection of Pump Parts

Before reassembling the pump, thoroughly inspect all parts, with special consideration given to following points:

- a. Inspect the pump body for erosion at all O-ring seal points and in valve and sleeve holes. Check main bearing housing for proper bearing fit. Check for cracks at the ports.
- b. Check for excessive wear in the cylinder heads. This can result from erosion and/or valve seat hammer.
- c. Check crankshaft assembly for general wear. Rotate main and cam bearing to check for roughness due to moisture or lack of grease damage. If bearings do not turn smoothly or appear to be damaged, they should be replaced. See section on **replacing bearings** in this manual.
- d. Carefully inspect cylinder sleeves. Polish sleeves not more than .008" — using No. 120 grit emery cloth. For final finish use a fine No. 320 grit emery cloth. If at this point all grooves have not been removed, replace the parts. **Note:** If there is some pitting only at the top of the sleeves, they can still be used. Grooves are more likely to be the problem here instead of pitting.

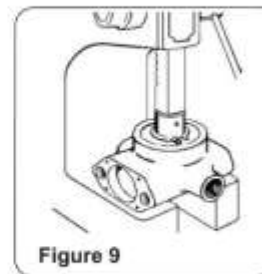

- e. Inspect the piston guides for chips, cracks and score marks. Compare guides with new one, if there is noticeable amount of clearance between the guide and sleeve wall, the guide should be replaced.
- f. Check for erosion on the underside of piston cup screw head. **Note:** The condition of the screws is very important - if there is erosion or grooves, leakage will occur.

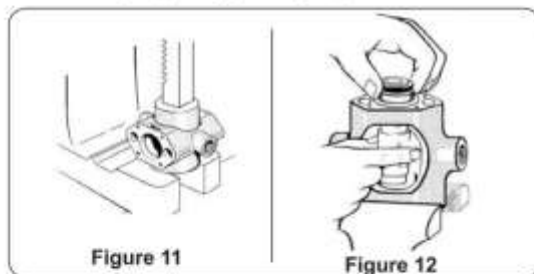

Figure 10

- g. Next check the connecting rod for wear. If there are visible signs of wear or damage to the hard coating, the connecting rod should be replaced. If there is more than .005" of wear, the connecting rod should be replaced. A worn connecting rod results in low volume, low pressure and a hammering sound. If not replaced, this situation will damage the cam bearing as well.
- h. The valve seat, poppet, spring and guide in valve sets should be carefully inspected for cracks, pitting, etc. and replaced as necessary. Note in particular the seat and matching poppet; replace both - as a set - if one new part will not mate with other old part.
- i. When repairing the Series 5200 pump it is usually a good idea to replace the piston cups. Piston repair kits are available with either leather, fabric (rubber-impregnated) or pure rubber (Buna-N) cups.
- j. Inspect complete crankshaft assembly for general wear. If the pump has had as much as 500 hours of use, it is suggested to replace the assembly. If broken cam bearing is found - the reason is usually that the pump has been operating over the 400 psi maximum. Another possible cause is that the pump has not been equipped with the proper surge tank or pulsation dampener to smooth out the pressure surges inherent in a large displacement 2-cylinder pump.
- k. Check all fittings - make certain that all sizes are correct for port size of the pump. Thoroughly inspect and clean before reinstalling.
- l. At this point all parts should have been inspected and cleaned. All parts should now be oiled (particularly the o-rings) and placed on a clean work bench for reassembly.

Reassembly

1. Using bearing seat tool, press the crankshaft assembly into the pump body (see Fig. 11).



2. Insert connecting rod over the cam bearing.
3. Insert both cylinder sleeves with oiled o-rings in cylinder bores.
4. Place pump in vise with ports horizontal (See Fig. 12). Rotate crankshaft to raise connecting rod to its highest position. Place support ring over top of connecting rod.
5. Insert piston guide.

Form L-0225P (6/11, Rev. B)

6. Place seal ring on top of guide.
7. Place cup backing plate with o-ring in place over seal ring.
8. Insert piston cup.
9. Insert cup spreader with new o-ring in place. Press into hollow of the piston cup.
10. Place a new copper washer gasket in the countersunk screw hole of cup spreader.
11. Tighten piston cap screw securely with 1/4" allen wrench.
12. Insert inlet and outlet valves with o-ring seals (See Fig. 13). These are identical, but in reverse positions.

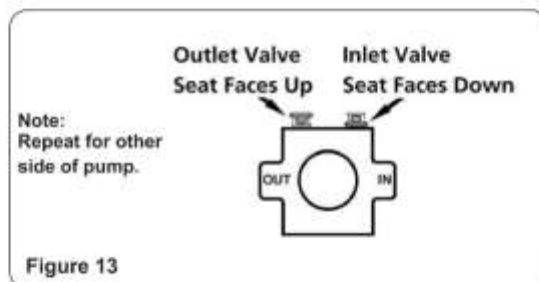

Note the pump ports which are the "IN" and "OUT" sides.

13. Install cylinder head with a new o-ring seal and tighten head bolts securely with a 9/16" wrench or socket.
 14. Repeat steps 5 through 13 for assembling the other half of the pump.
- Note:** Follow proper lubrication procedures as listed in the Operating the Pump section of this manual.
15. Replace the nameplate. The pump can now be tested - pumping clear water.

Main Bearing Replacement

1. Remove set screws, bolts or keys from the shaft and smooth off any burrs or rough spots.
2. Remove retainer rings from shaft with external pliers. For convenience, you can remove just the one closest to the drive end of the shaft.
3. Support bearing in arbor press and press shaft out as shown in Fig. 14.
4. New bearing is pressed on in reverse manner. Front retainer ring (closest to cam bearing) should be in place to provide a stop for the bearing.
5. After bearing has been pressed into place, install the other retainer ring in shaft groove with the external pliers as before.



Figure 14

-6-

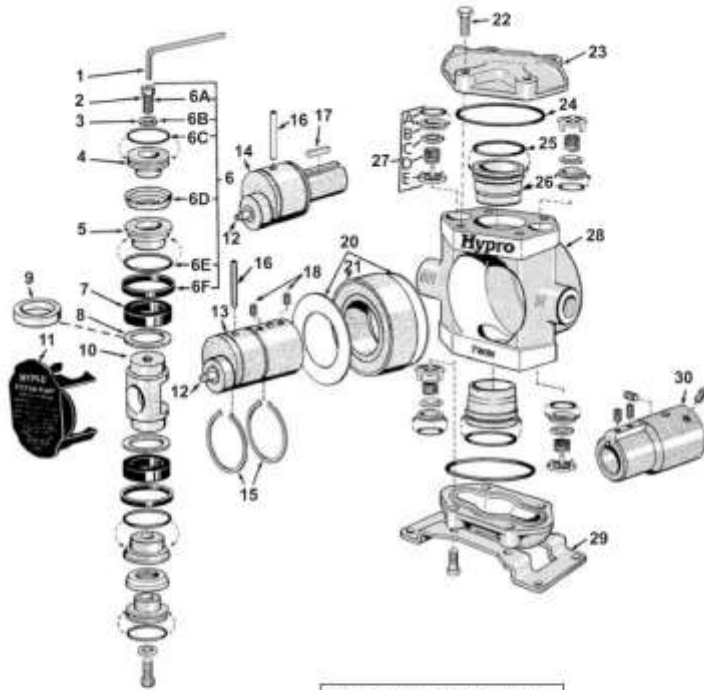

NOTE: When ordering parts, give quantity, part number, description, and complete model number. Reference numbers are used **ONLY** to identify parts in the drawing and are **NOT** to be used as order numbers.

Ref. No.	Qty. Req'd.	Part No.	Description
1	1	3020-0008	Allen Wrench (Optional)
2	2	2220-0013	Piston Cap Screw
3	2	2270-0012	Washer
4	2	1830-0039	Piston Cup Spreader
5	2	1410-0054	Cup Backing Plate
6	1	3430-0037	Piston Stack Parts Kit with Leather Cups (Standard)
6	1	3430-0039	Piston Stack Parts Kit with Fabric Cups (Model 5200-F)
6	1	3430-0189	Piston Stack Parts Kit with Buna-N Cups (Model 5200-R)
7	2	1440-0005	Piston Guide
8	2	1410-0018	Support Ring For 5210 Models Only
9	2	1410-0020	Support Ring For 5206 Models Only
10	1	0503-5200	Connecting Rod
11	1	0602-5200	Safety Cover
12	1	2405-0006	Grease Fitting Assembly
13	1	See Listing	Crankshaft (Hollow Shaft Models)
14	1	See Listing	Crankshaft (Solid Shaft Models)
15	2	1810-0001	Retainer Ring
16	1	1600-0013	Crankpin Retainer

Piston Stack Parts Kits

Leather Cup Kit No. 3430-0037 (STD)

Consists of two each of the following parts: No. 2220-0013 Piston Cap Screw (Ref. 6A), No. 2270-0012 Washer (Ref. 6B), No. 1720-0030 O-Ring (Ref. 6C), No. 2150-0001 Leather Cup (Ref. 6D), No. 1720-0065 O-Ring (Ref. 6E) and No. 1440-0012 Seal Ring (Ref. 6F).

Fabric Cup Kit No. 3430-0039

Same as Leather Cup Kit except with two No. 2150-0012 Fabric Cups.

Rubber Cup Kit No. 3430-0189

Same as Leather Cup Kit except with two No. 2150-0042 Rubber Cups.

Crankshaft Assemblies

Sub-Assemblies

Include Grease Fitting (Ref. 12), Crankshaft with cam bearing (Ref. 13 or 14) and Crankpin Retainer (Ref. 16).

Complete Assemblies

Include Sub-Assembly components plus Retaining Rings (Ref. 15), slinger rings (Ref. 20) and Bearing (Ref. 21).

Complete Sub-Assembly PART NO.	Pump Assembly PART NO.	Model Number
with 1-3/8" Hollow PTO Shaft (Ref. 13)		
5503-5206	5501-5206	5206C-H
5503-5210	5501-5210	5210C-H
with 1" Solid Shaft (Ref. 14)		
5003-5206	5001-5206	5206C
5003-5210	5001-5210	5210C

Ref. No.	Qty. Req'd.	Part No.	Description
17	1	1610-0005	Key (Solid Shaft Models)
18	2	2230-0003	Set Screw
20	2	1410-0006	Slinger Ring
21	1	2005-0002	Main Bearing
22	8	2210-0062	Cylinder Head Bolt
23	2	0203-5200CB	Cylinder Head
24	2	1720-0028	O-Ring - for cylinder head
25	2	1720-0019	O-Ring - for cylinder sleeve
26	2	3550-0007	Cylinder Sleeve
27	4	3400-0038	Valve Assembly—Consists of: O-ring (Ref. A), Valve Seat (Ref. B), Valve Poppet (Ref. C), Valve Spring (Ref. D) and Valve Spring Retainer (Ref. E)
28	1	0100-5200C	Body
29	1	1510-0024	Base
30	1	1320-0081	Adapter-Adapts 1" solid shaft to 1- 3/8" 6-spline PTO hollow shaft (Includes set screws.)



Hazardous Substance Alert

1. Always drain and flush pump before servicing or disassembling for any reason (see instructions).
2. Always drain and flush pumps prior to returning unit for repair.
3. Never store pumps containing hazardous chemicals.
4. Before returning pump for service/repair, drain out all liquids and flush unit with neutralizing liquid. Then, drain the pump. Attach tag or include written notice certifying that this has been done. Please note that it is illegal to ship or transport any hazardous chemicals without United States Environmental Protection Agency Licensing.

Troubleshooting

Symptom	Probable Cause(s)	Corrective Action(s)
Low Discharge	Pump not primed	See Priming section of this manual.
	Clogged suction strainer	Clear strainer screen.
	Suction hose collapsed	Replace suction hose with stronger wall hose.
	Excessive vacuum on inlet	Reduce inlet restrictions by eliminating items such as elbows, valves or too small of inlet hose.
	Pump running at wrong speed	Check speed of pump and adjust accordingly.
Low Pressure	Valves worn or hung-up	Inspect valves and replace if necessary.
	Unloader or Relief Valve set improperly	Readjust unloader or relief valve.
	Nozzle worn or damaged	Check nozzle and replace.
	Valves worn or hung-up	Inspect valves and replace if necessary.
Liquid leaking from center of pump	Insufficient power from gas engine or electric motor	Check performance chart to find proper HP needed for flow and pressure desired.
	Seals worn	Replace with new seal kit.

Limited Warranty on Hypro/SHURflo Agricultural Pumps & Accessories

Hypro/SHURflo (hereafter, "Hypro") agricultural products are warranted to be free of defects in material and workmanship under normal use for the time periods listed below, with proof of purchase.

- Pumps: one (1) year from the date of manufacture, or one (1) year of use. This limited warranty will not exceed two (2) years, in any event.
- Accessories: ninety (90) days of use.

This limited warranty will not apply to products that were improperly installed, misapplied, damaged, altered, or incompatible with fluids or components not manufactured by Hypro. All warranty considerations are governed by Hypro's written return policy.

Hypro's obligation under this limited warranty policy is limited to the repair or replacement of the product. All returns will be tested per Hypro's factory criteria. Products found not defective (under the terms of this limited warranty) are subject to charges paid by the returnee for the testing and packaging of "tested good" non-warranty returns.

No credit or labor allowances will be given for products returned as defective. Warranty replacement will be shipped on a freight allowed basis. Hypro reserves the right to choose the method of transportation.

This limited warranty is in lieu of all other warranties, expressed or implied, and no other person is authorized to give any other warranty or assume obligation or liability on Hypro's behalf. Hypro shall not be liable for any labor, damage or other expense, nor shall Hypro be liable for any indirect, incidental or consequential damages of any kind incurred by the reason of the use or sale of any defective product. This limited warranty covers agricultural products distributed within the United States of America. Other world market areas should consult with the actual distributor for any deviation from this document.

Return Procedures

All products must be flushed of any chemical (ref. OSHA section 1910.1200 (d) (e) (f) (g) (h)) and hazardous chemicals must be labeled/tagged before being shipped* to Hypro for service or warranty consideration. Hypro reserves the right to request a Material Safety Data Sheet from the returnee for any pump/product it deems necessary. Hypro reserves the right to "dispose as scrap" products returned which contain unknown fluids. Hypro reserves the right to charge the returnee for any and all costs incurred for chemical testing, and proper disposal of components containing unknown fluids. Hypro requests this in order to protect the environment and personnel from the hazards of handling unknown fluids.

Be prepared to give Hypro full details of the problem, including the model number, date of purchase, and from whom you purchased your product. Hypro may request additional information, and may require a sketch to illustrate the problem.

Contact Hypro Service Department at 800-468-3428 to receive a Return Merchandise Authorization number (RMA#). Returns are to be shipped with the RMA number clearly marked on the outside of the package. Hypro shall not be liable for freight damage incurred during shipping. Please package all returns carefully. All products returned for warranty work should be sent shipping charges prepaid to:

HYPRO
Attention: Service Department
375 Fifth Avenue NW
New Brighton, MN 55112

For technical or application assistance, call the Hypro Technical/Application number: 800-445-8360, or send an email to: technical@hypropumps.com. To obtain service or warranty assistance, call the Hypro Service and Warranty number: 800-468-3428, or send a fax to the Hypro Service and Warranty FAX: 651-766-6618.

*Carriers, including U.S.P.S., airlines, UPS, ground freight, etc., require specific identification of any hazardous material being shipped. Failure to do so may result in a substantial fine and/or prison term. Check with your shipping company for specific instructions.



Pentair

SPRAY & INJECTION TECHNOLOGIES GROUP

375 Fifth Avenue NW • New Brighton, MN 55112

Phone: (651) 766-6633 • 800-445-8360 • Fax: 651-766-6618

www.hypropumps.com

Printed in the USA
2011 Hypro



TABLE OF CONTENTS

SMARTFLOW II FOR BUFFALO TURBINE

SmartFlow II Manual

SMARTFLOW II DESCRIPTION	1-2	CALIBRATION FACTORS	30 - 38
TOTAL COUNTERS	3 - 6	1. ALARM SETTING	30
VOLUME	5	2. SPEED CAL	31
AREA	5	3. CONT SPEED	31
DISTANCE	6	4. TEST SPEED	32
TIME	6	5. TARGET RATE	33 - 34
HOURS	6	6. MIN SPEED	35
SMARTFLOW II CONTROL PANEL FUNCTIONS	7 - 25	7. MAX SPEED	36
LCD DISPLAY	8	8. FLOW CAL	37
ALARMS	9	HOW TO CALIBRATE	38
WARNING LED	9	RELOADING CALIBRATION DEFAULTS	39 - 40
ROTARY DIAL FUNCTIONS	10 - 19	SPECIAL CALIBRATION MODES	41 - 44
1. DISTANCE	11	1. UNITS	43
2. SPEED	12	2. VEHICLE ID	43
3. AREA (1) (2) (3)	13	3. WIDTH	43
4. VOLUME/MINUTE	14	4. CONTROL SPEED	43
5. VOLUME (1) (2) (3)	15	5. TANK ALARM SET POINT	43
6. TANK	16	6. FILL TANK SIZE	43
7. TIME	17	7. AUTOMATIC SHUTOFF	44
8. RATE	18 - 19	OPERATION	45 - 51
TOGGLE SWITCHES	20 - 23	STARTUP/SHUTDOWN	46
1. POWER ON/OFF SWITCH	20	POWER UP MESSAGES	47 - 48
2. ENGINE START	20	SELECTING APPLICATION RATE	49
3. CHOKE	20	CLEARING COUNTERS	50
4. FLUSH	21	ADJUSTING TANK VOLUME	51
5. NOZZLE ROTATE	21	TROUBLESHOOTING	52 - 55
6. SPRAY TOGGLE	22	ERROR CODES	53 - 55
7. RATE TOGGLE	23	ERR 1	53
PUSH BUTTONS	24 - 25	ERR 2	54
CALIBRATION	26 - 40	ERR 3	55
HOW TO ENTER CALIBRATION MODE	28 - 29	ERR 4	55
		MESSAGE/WARNINGS	56 - 57
		NO CONSOLE POWER	57
		WARNING LED & AUDIBLE ALARM	57
		LOW VOLTAGE DETECTION	57

DESCRIPTION

SMARTFLOW II FOR BUFFALO TURBINE

Installation, Operation and Maintenance Manual

The SmartFlow II control provides programmable microcomputer control for Clarke spraying systems. The SmartFlow II control offers the following features:

- The SmartFlow II control uses data from speed and flow sensor to regulate the flow of the spraying system. This automatically maintains the target application rate.
- The SmartFlow II control can operate alone, or for GPS-controlled Variable Rate Applications (VRA). It can use an RS232 Serial Link to send data to and receive commands from an external computer.
- The SmartFlow II control is available for both gas and electric spraying systems.
- The SmartFlow II accumulates several totals (Volume, Area, Distance, Time and Hours) to help verify spraying applications.



Total Counters

The SmartFlow II has five Total Counters:

TOTAL COUNTERS	3 - 6
VOLUME	5
AREA	5
DISTANCE	6
TIME	6
HOURS	6

TOTAL COUNTERS

SMARTFLOW II FOR BUFFALO TURBINE

Total Counters

The SmartFlow II accumulates the following totals to document spraying applications:

COUNTER	DESCRIPTION	UNITS
Volume	The amount of liquid applied since the counter was last reset.	Tenths of a gallon or tenths of a liter.
Area	The total application area since the counter was last reset.	Acres or hectares
Distance	The distance the vehicle has traveled while spraying since the counter was last reset.	Miles or kilometers
Time	The spray time since the counter was last reset.	Hours
Hours	The cumulative spray time. This counter cannot be reset.	Hours

Volume Counters

Three Volume Counters are provided. When in the **VOLUME** position, the selected counter is indicated by the number icon (1, 2, 3) in the Data display. A different counter can be selected by using **INC** key.

NOTE: The **DEC** key is not used since that is used to clear the counter in some models.

Cycling power or brown-outs will not change the selection. The user cannot change the counter selection while in **CALIBRATION** or **SPECIAL CALIBRATION**, but it can be changed while in **TEST SPEED** mode.

If a flow signal is present, then volume continues to accumulate while in the **VARIABLE**, **CONTINUOUS** or **OFF** modes. All three Volume Counters are always active and will accumulate volume (not just the selected or displayed counter).

Area and Volume Counters are coupled together (as pairs) so selecting Volume Counter 1 also selects Area Counter 1. This was done so user can easily see how much Volume was applied to a particular area (Volume 1 is always applied to Area 1, and Volume 2 to Area 2 etc.).

Area Counters

Three Area Counters are provided. When in the **AREA** position, the selected counter is indicated by the number icon (1, 2, 3) shown in the Data display. A different counter can be selected by using the **INC** key.

NOTE: The **DEC** key is not used since that is used to clear the counter in some models: 'Lite' and 'D'.

Cycling power or brown-outs will not change the selection. The user can not change the counter selection while in **CALIBRATE** or **SPECIAL CALIBRATE** but it can be changed while in **TEST SPEED** mode.

Area is only accumulated while in the **VARIABLE** mode (and not "Lo Speed" or "Hi Speed"), and all three counters are active and will accumulate Area (not just the selected or displayed counter). When in **CONTINUOUS** or **OFF** mode, all three Area Counters stop accumulating area.

Area and Volume Counters are coupled together (as pairs) so selecting Area Counter 1 also selects Volume Counter 1. This was done so the user can easily see how much volume was applied to a particular area (Volume 1 is always applied to Area 1, and Volume 2 to Area 2 etc.).

The **SPEED** calibration factor can be changed at any time (before or after a field is completed) and the correct area will be re-computed.

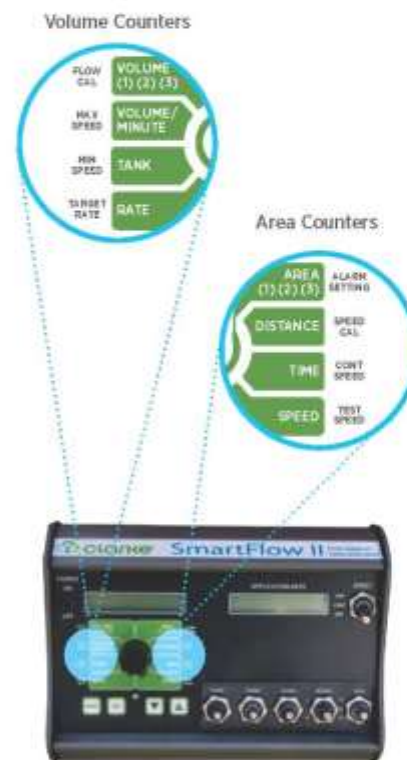

CONTROL PANEL FUNCTIONS

SMARTFLOW II FOR BUFFALO TURBINE

Control Panel Functions

This section describes the functions of the control panel for the SmartFlow II control.

SMARTFLOW II CONTROL PANEL FUNCTIONS	7 - 25
LCD DISPLAY	8
ALARMS	9
WARNING LED	9
ROTARY DIAL FUNCTIONS	10 - 19
1. DISTANCE	11
2. SPEED	12
3. AREA (1) (2) (3)	13
4. VOLUME/MINUTE	14
5. VOLUME (1) (2) (3)	15
6. TANK	16
7. TIME	17
8. RATE	18 - 19

TOGGLE SWITCHES	20 - 23
1. POWER ON/OFF SWITCH	20
ENGINE START	20
CHOKE	20
FLUSH	21
NOZZLE ROTATE	21
SPRAY TOGGLE	22
RATE TOGGLE	23
PUSH BUTTONS	24 - 25



CONTROL PANEL FUNCTIONS

SMARTFLOW II FOR BUFFALO TURBINE

LCD Displays

The Clarke control box has two LCD displays (Data display window and Application Rate display window), each of which is capable of displaying any combination of digits, decimal points, and icons as shown in the illustration below.



SMARTFLOW II CONSOLE

Alarm On/Off Toggle Switch

An Audible Alarm (beeper) sounds when there is an error. A rear mounted toggle switch (on the back of the SmartFlow II console) is used to turn off (disable) the Audible Alarm.

The Warning LED and "ERROR" indicator in the Data display window will also be lit.

Warning LED

While in VARIABLE or CONTINUOUS mode, the Warning LED, and the Audible Alarm will turn on (steady) whenever there is more than 10% error in the application rate. However, the audible alarm (only) can be delayed if the "Alarm Setting" is used.

SMARTFLOW II (REAR VIEW)



SMARTFLOW II CONSOLE



1. Rotary Dial Position: **DISTANCE**

Function: Distance Traveled

The **DISTANCE** position shows the distance traveled in 0.1 increments from 0 – 9,999.9 miles or kilometers and then increments from 10,000 – 99,999 miles or kilometers.* This is shown in the Data display window.

The Distance Counter will only accumulate when in **VARIABLE** mode (and not "Lo Speed" or "Hi Speed"). If in **CONTINUOUS** or **OFF** mode, it will display the last accumulated distance.

Use the **RESET** button for clearing distance.

Distance is saved to **EEPROM** during brown-outs or when power is turned **OFF**.

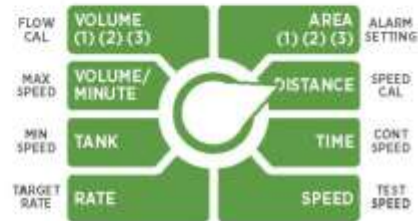

***NOTE:** Once 99,999 is reached, Data display will show OFL (Overflow) and stop counting. The user must clear Distance to resume counting.

Rotary Dial Functions (cont.)**3. Rotary Dial Position: AREA 1, 2, 3****Function: Acres Sprayed**

Three Area Counters are provided. When in the **AREA** position, the selected counter is indicated by the number icon (1, 2, 3) shown in the Data display. A different counter can be selected by using the **INC** key.

NOTE: The **DEC** key is not used, since it is used to clear the counter in some models.

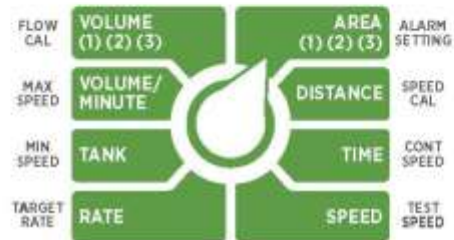

Cycling power or brown-outs will not change the selection. The user cannot change the counter selection while in **CALIBRATION** or **SPECIAL CALIBRATION**, but it can be changed while in **TEST SPEED** mode.

Area is only accumulated while in **VARIABLE** mode (and not "Lo Speed" or "Hi Speed"), and while all three counters are active and will accumulate area (not just the selected or displayed counter). When in the **CONTINUOUS** or **OFF** mode, all three Area Counters stop accumulating area.

In English units it counts from 0.1 – 9,999.9 acres, then drops the decimal point to count up to 99,999 acres. Metric counts from 0.01 – 999.99 hectares, then shifts the decimal to count up to 9,999.9 hectares, then drops the decimal point to count up to 99,999 hectares.

Area and Volume Counters are coupled together (as pairs), so selecting Area Counter 1 also selects Volume Counter 1. This was done so the user can easily see how much volume was applied to a particular area. (Volume 1 is always applied to Area 1, and Volume 2 to Area 2 etc.).

The **SPEED** calibration factor can be changed at any time (before or after a field is completed) and the correct area will be re-computed.

NOTE: Once the display reaches 99,999 it will display **OFL (Overflow)** in the Data display window and stop counting. The user must clear the Area to resume counting. Use the **RESET** button for clearing **AREA**.

CONTROL PANEL FUNCTIONS

SMARTFLOW II FOR BUFFALO TURBINE

Rotary Dial Functions (cont.)

4. Rotary Dial Position: **VOLUME/MINUTE**

Function: Ounces or Milliliters per Minute

The **VOLUME/MINUTE** position shows a range from 0.001 - 16,777 oz/min or from 0.1 - 99,999 mL/min. A typical application is 42 oz/acre at a width of 200 ft at 10 mph which generates a typical volume/minute of 252 oz/min or 7.45 L/min.

English volume per minute is displayed with one or more decimal places that range from 0.001 - 99,999 gallons/minute. Metric volume per minute is displayed with zero or one decimal place that ranges from 0.1 - 99,999 ml/min. For English and Metric automatic decimal shift and hysteresis is the same as described in the **RATE** section (page 18).

VOLUME/MINUTE operates while in **VARIABLE**, **CONTINUOUS** or **OFF** mode. As long as a flow signal is present, control can only be made once every second, making it respond much more slowly to speed changes.

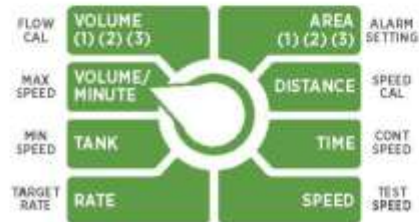

Rotary Dial Functions (cont.)

5. Rotary Dial Position: **VOLUME (1)(2)(3)**

Function: Volume Pumped in
Gallons or Liters

Three Volume Counters are provided. When in the **VOLUME** position, the selected counter is indicated by the number icon (1, 2, 3) in the Data display window and a different counter can be selected by using **INC** key.

NOTE: The **DEC** key is not used since that is used to clear the counter in some models.

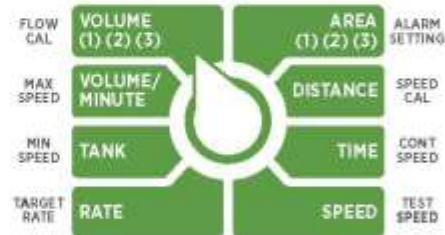

Cycling power or brown-outs will not change the selection. The user cannot change the counter selection while in **CALIBRATE** or **SPECIAL CALIBRATE** but it can be changed while in **TEST SPEED** mode.

If a flow signal is present, then volume continues to accumulate while in **VARIABLE**, **CONTINUOUS** or **OFF** mode. All three Volume Counters are always active and will accumulate volume (not just the selected or displayed counter).

The **VOLUME** mode displays the volume pumped from .01 – 999.99 gallons or liters and then from 1,000.0 – 9,999.9 gallons or liters and then from 10,000 – 99,999 gallons or liters. Once it reaches 99,999 it will display "OFL" (Overflow) and stop counting. The user must clear **VOLUME** to resume counting. Use the **RESET** button for clearing **VOLUME**.

Area and Volume Counters are coupled together (as pairs) so selecting Volume Counter 1 also selects Area Counter 1. This was done so user can easily see how much volume was applied to a particular area (Volume 1 is always applied to Area 1, and Volume 2 to Area 2 etc.).

The Flow Meter calibration factor can be changed at any time (before or after an application is completed), and the correct volume will be re-computed.

CONTROL PANEL FUNCTIONS

SMARTFLOW II FOR BUFFALO TURBINE

Rotary Dial Functions (cont.)

6. Rotary Dial Position: **TANK**

Function: Amount of Liquid in the Tank

The **TANK** position shows the amount of liquid remaining in the tank, to the nearest tenth of a gallon or liter. An alarm (see below) will be given when the tank level equals or drops below the Set Point Calibration Factor (default 10 gallons or 37.85 liters) while in **VARIABLE, CONTINUOUS** or **OFF** mode. This alerts the user that the tank is low, whether he is spraying or has stopped. The user can stop the audible and visual Tank Alarm by momentarily pressing the **RESET** button (while in any position).

If a flow signal is present, then **TANK** continues to decrement while in **VARIABLE, CONTINUOUS,** or **OFF** mode.

The tank volume can be adjusted by setting the **SPRAY** switch to **OFF**, and then using the **INC** or **DEC** buttons to adjust it from 0.0 - 6553.5 gallons or liters. For safety, this can only be done while the **SPRAY** switch is in **OFF**.

Adjusting the tank volume to any value greater than zero will always activate the Tank Alarm function. Adjusting it to 0.0 will disable and clear the Tank Alarm. Once activated, the alarm will beep On and Off slowly. The Warning LED will turn on and the Application Rate display will alternate between "FILL" and normal until the user adjusts the **TANK** value above the Tank Alarm Set Point (alarm will stop) or back to 0.0 to disable it.

The **TANK** value cannot be changed while in Calibration Mode or Special Cal mode, but it can be changed while in **TEST SPEED** mode.

The "FILL" message will not flash while in Calibration Mode, or Special Calibration Mode.

NOTE: Setting the **SPRAY** switch to **OFF** will stop the 10% Rate Error Alarm (steady tone) but will not stop the Tank Alarm. If the user clears the Tank Alarm by pressing the **RESET** button, it will stay cleared even if the SmartFlow II power is turned on and off.

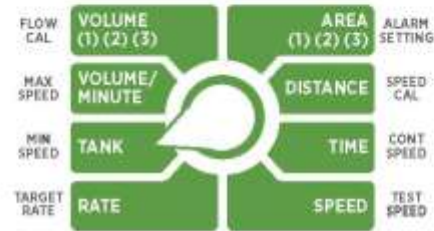

Rotary Dial Functions (cont.)

7. Rotary Dial Position: **TIME**

Function: Time Spraying Since Counter Was Last Reset

The **TIME** position displays the spray time since the counter was last reset. It displays from 0.1 – 9999.9 hours and then from 10,000 – 99,999 hours. Once it reaches 99,999 it will display OFL (overflow).

The Time Counter accumulates spray time when in **VARIABLE** (and not “Lo Speed” or “Hi Speed”) or **CONTINUOUS** mode and the **Pressure OK** or the Flow Meter is detecting Flow.

Use the **RESET** button for clearing **TIME**.

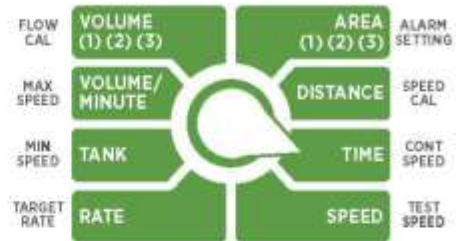

CONTROL PANEL FUNCTIONS

SMARTFLOW II FOR BUFFALO TURBINE

Rotary Dial Functions (cont.)

8. Rotary Dial Position: **RATE**

Function: Displays Actual Rate in oz/acre or milliliters/hectare

The **RATE** position displays in the Data display window, and also will show the same value in the Application Rate display window.

The **RATE** position displays .001 – 99,999 oz/acre or 0.1 – 99,999 mL/hectare.

Rate operates while in **VARIABLE** and **CONTINUOUS** mode but will go to zero in the **OFF** mode, even if a flow signal is present. It also goes to zero if in **VARIABLE** mode, and “*Lo SPEED*” or “*Hi SPEED*” in Application Rate display.

RATE is displayed with one or more decimal places depending on the rate as shown in the tables to the right. In general, the decimal point is automatically shifted to eliminate redundant digits that add “jitter” while maintaining a 1% resolution for high accuracy.

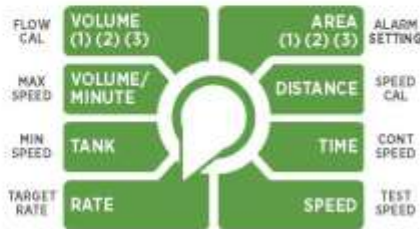

ENGLISH UNITS

When slowly **increasing from zero to maximum**, the decimal point will automatically shift at the following values:

DECIMAL PLACES	RATE VALUE
3	0.000 – 1.999
2	2.00 – 9.99
1	10.0 – 99.9
None	100 – 16,777 (displays OFL)

When slowly **decreasing from maximum to zero**, the decimal point will automatically shift at the following values:

DECIMAL PLACES	RATE VALUE
None	16,777 – 90
1	89.9 – 9.0
2	8.99 – 1.00
3	0.999 – 0.000

Between each of the above four decimal ranges, a hysteresis window as shown below will prevent rapid switching back and forth between decimal points.

DECIMAL PLACES	RATE VALUE
2 or 3	1.000 – 1.990
1 or 2	9.00 – 9.90
0 or 1	90.0 – 99.9

METRIC UNITS

When slowly **increasing from zero to maximum**, the decimal will shift at the following values:

DECIMAL PLACES	RATE VALUE
1	0.1 – 99.9
None	100 – 99,999 (then displays OFL)

When slowly **decreasing from maximum to zero**, the decimal will shift at the following values:

DECIMAL PLACES	RATE VALUE
None	99,999 – 90
1	89.9 – 0.1

If an error between the Actual Rate and the Target Rate is $\geq 5\%$, then the display simply shows the Target Rate. If the error ever exceeds 10%, then the Warning LED and the audible alarm will turn on (steady). However, the Audible Alarm (only) can be delayed by adjusting the Alarm Setting calibration value.

Rotary Dial Functions (cont.)

NOTE: The Application Rate display window will always match the RATE displayed in the Data display window except for if the Application Rate display window:

- Displays Target Rate for 3 seconds when the Rate Toggle switch is changed and the "FILL" message does not alternate with it.
- Alternates between "Lo" and "SPEED" when in VARIABLE mode (and not PCOFF) if the SPEED is below "min Speed". It will alternate between "hi" and "SPEED" if the SPEED is above Max Speed: Cal Factor. This will take precedence over the 3 second display of Target Rate.
- Displays "OFF" when in OFF mode, or displays "PCOFF", a PC-issued OFF command, by sending Target=0. OFF, takes precedence over PCOFF, and both take precedence over the "Lo/HI SPEED" and "OFL" messages.

If some error occurs, "Err 1" - "Err 4" will display and take precedence over the the above messages (OFF, PCOFF, OFL, FLUSH and HI/Lo SPEED). (See Error Codes, pages 53-55 for details).

- It will alternate "FILL" when the Tank Level is low and these messages: OFF, PCOFF, OFL, ErrX. ("FILL" is not displayed when it's alternating between "Lo/HI" and "SPEED".)
- The MAN Icon is on when in CONTINUOUS mode and the AUTO icon is on when n VARIABLE mode.
- A number icon (1,2,3) will turn on, based on the rate selected with the Rate Toggle switch. When in PCCC mode, these numbers will be off. This will remind the user the SmartFlow II is under PC control and it's using a Target Rate received from the PC, rather than Target Rate 1, 2 or 3.

The Application Rate display is blanked during power up when the SmartFlow II Hours and REV level are displayed.



CONTROL PANEL FUNCTIONS

SMARTFLOW II FOR BUFFALO TURBINE

Toggle Switches

The SmartFlow II has six toggle switches:

1. Power On/Off Switch

The **POWER** switch is a single-pull, single-throw (SPST) switch. The **POWER** switch turns the SmartFlow II control on and off. In the **OFF** position, this switch also grounds the magneto on a gas spraying system.

2. Engine Start

The **ENGINE START** is an on/off momentary toggle switch, which will start the engine.

3. Choke

The **CHOKE** switch is a momentary toggle switch. For non fuel-injected engines, a solenoid would be needed for this function to operate.



Toggle Switches (cont.)

4. Flush

If the **SPRAY** switch is in the **OFF** position and you press the momentary **FLUSH** toggle switch for **one second**, then the SmartFlow II will automatically flush the sprayer for one minute. It will display "FLUSH" in the Application Rate display and will run the gas engine to full throttle. Running to full throttle will generate blower pressure, which will activate the Pressure OK Switch when it reaches 1 PSI.

The SmartFlow II will wait until it receives the **Pressure OK**, and then it will turn on the spray pump. If the Pressure OK Switch does not activate within 3 seconds, the **ERROR 5** message will be displayed in the Application Rate display window. It will continue to display "Err-5" until **Pressure OK** is activated. This gives you enough time to start the engine or complete whatever is required to get the blower pressure up. When **Pressure OK** becomes active, **ERROR 5** will clear and the Flush operation will continue its normal process. You may also cycle power to clear **ERROR 5**.

Once **FLUSH** is started, it will continue for one minute. The only way to abort the **FLUSH** operation is to power down, or if the **Pressure OK** becomes low it will abort and stop the pump (displaying **OFF**). Then, you will have to press the Flush Switch to start over.

During the last 15 seconds of the one-minute **FLUSH**, the SmartFlow II will adjust the Flow Rate to match **RATE 1** at the Continuous Speed. After one minute, it will reduce the engine throttle to minimum, stop the pump and turn the **FLUSH** solenoid off to end the **FLUSH** operation and display the normal "OFF" instead of "FLUSH".

During the **FLUSH** operation, only **ERROR CODE 5** is possible. The Speed and Flow Per Minute, and **RATE** will operate normally in the Data display. The Area, Distance, Volume, Tank and Time will not accumulate. The Warning LED and audible alarm will remain off.

During the one-minute **FLUSH** operation, you can watch **Volume/Minute** to ensure it is being flushed out at a high flow. During the last 15 seconds, you can use the **RATE** mode to ensure automatic control is operating correctly.

5. Rotate Nozzle

This toggle switch is a momentary 3-way switch that lets you to move the nozzle up to 90 degrees right or left. This function allows you to direct the product spray into inaccessible or hard to reach areas.



CONTROL PANEL FUNCTIONS

SMARTFLOW II FOR BUFFALO TURBINE

Toggle Switches (cont.)

6. Spray Toggle Switch

The **SPRAY** toggle switch has three positions: **VAR** (Variable), **CONT** (Continuous), and **OFF** (OFF mode, not Power Off).



SPRAY TOGGLE SWITCH POSITIONS

CALIBRATION FACTOR	DESCRIPTION
VAR Position	Variable Mode The SmartFlow II control varies the pump speed to automatically maintain the selected application rate based on flow and speed. Total Flow, Distance, Time, Hours, and Area Counters accumulate in this mode.
CONT Position	Continuous Mode The SmartFlow II control varies the pump speed to automatically maintain the selected application rate based on flow only. This mode can be used to spray while the vehicle is stopped. Total Flow, Time, and Hours Counters accumulate in this mode.
OFF Position	Off Mode The sprayer is stopped, and the Application Rate, FlowPer Minute, and Active Swath values go to zero. Total Flow and Tank Counters accumulate in this mode in case flow does not stop immediately.

VAR

In the **VARIABLE** position, the **AUTO** icon turns on in the Application Rate display window. As the Speed of the vehicle can vary, the SmartFlow II will vary the drive to the electric pump to automatically maintain the selected Target Rate (1, 2, or 3). Both Speed and Flow are measured to compute and control the application rate (oz/acre).

CONT

The **CONTINUOUS** mode can be used to spray while stationary or parked. In this position, the **MAN** icon will turn on in the Application Rate display window. The Speed is assumed to be continuous, or at a constant speed. The SmartFlow II will measure the flow (but not the speed) and automatically adjust the sprayer to maintain the selected **TARGET RATE*** (1, 2, or 3) on a "continuous" speed, even though the actual **CONTINUOUS** ground speed may vary, or be stopped. Only the flow is measured to compute and control the application rate (oz/acre) independent of actual ground speed.

When switched from **OFF** to **CONTINUOUS** mode, the SmartFlow II will turn on and off as described in **VARIABLE** mode.

The **CONTINUOUS** speed calibration value can be set from 2.0 – 45.0 mph (or km/h), and the same speed is used for all three Rates. If the **SPEED** position is selected on the rotary switch, it will flash the Continuous Speed Calibration Factor rather than show the actual speed.

NOTE: The Target Rate cannot be adjusted by using the INC and DEC buttons.

OFF

In the **OFF** mode, the Application Rate display will show "OFF" and the **AUTO** and **MAN** icons will turn off. The SmartFlow II will stop the sprayer.

Toggle Switches (cont.)

7. Rate Toggle Switch

This toggle switch is used to select from 1 to 3 pre-programmed Application Rates for **VARIABLE** or **CONTINUOUS** spray rate control. A Number icon 1, 2, 3 will turn on in the Application Rate display window to reflect which Rate is selected.

When the **RATE** switch is changed, the Application Rate display window will show the selected Target Rate for 3 seconds if in **VARIABLE** or **CONTINUOUS** mode. It is not displayed while in the **OFF** mode because "OFF" is being displayed, but the new Rate is still selected.



Push Buttons (cont.)**2. INC (+) and****3. DEC (-)**

The **INC/DEC** buttons are used to enter or adjust values in the display.

If in **VOLUME** or **AREA** mode, the **INC/DEC** buttons will select 1 of 3 counters.

If in the **TANK** mode, then the **INC** or **DEC** buttons are used to change the tank level. This also works while in the **PCCC** (PC Command/Control) mode.

If in **SPEED** position and **TEST SPEED** mode, then the **INC** and **DEC** buttons will adjust the test speed.

In **CALIBRATION** or **SPECIAL CALIBRATION** mode, pressing the **INC** or **DEC** buttons increases or decreases each calibration value. The longer the key is pressed, the faster the value will change.

4. CAL Button

Used to start and stop the calibration modes.
(See **Calibration Modes** on pages 26-40, and **Special Calibration Modes** on pages 41-44.)



SMARTFLOW II FOR BUFFALO TURBINE

Calibration Factors

The SmartFlow II control has eight Calibration Factors:

CALIBRATION FACTOR	ROTARY SWITCH POSITION	DESCRIPTION
ALARM SETTING	AREA (1) (2) (3)	Sets the delay time for triggering the Audible Alarm.
SPEED CAL	DISTANCE	Specifies the distance the vehicle travels between speed sensor pulses. This enables the SmartFlow II control to accurately measure speed, distance, area and application rate.
CONT. SPEED	TIME	The speed that is used in CONTINUOUS mode.
TEST SPEED	SPEED	Not a true Calibration Factor, but a method of testing the sprayer.
TARGET RATE	RATE	Sets the three preset Target Application Rates.
MIN SPEED	MIN SPEED	The minimum speed allowed in VARIABLE mode. If the vehicle goes below this speed, the control goes into OFF mode until the speed exceeds this number again.
MAX SPEED	VOLUME/MINUTE	The maximum speed allowed in VARIABLE mode. If the vehicle exceeds this speed the control goes into OFF mode until the speed goes below this number again.
FLOW CAL	FLOW CAL	Specifies the number of flow sensor pulses per gallon applied. This enables the SmartFlow II control to accurately measure total flow, flow per minute, and application rate.

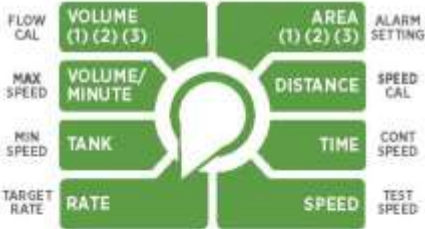

CALIBRATION

SMARTFLOW II FOR BUFFALO TURBINE

How to Enter Calibration Mode

Two methods can be used to enter Calibration Mode:

1. Only allows user to view the CAL factors.

To enter "View" Calibration Mode:

- Toggle the **SPRAY** switch to **OFF**.
- Press and hold the **CAL** button for 1 second. The word "**CAL**" will be displayed in the Application Rate display window and the Data display window will show the Calibration Factors. The red Warning LED will remain off as a reminder the user cannot change the Calibration Factors.

To exit "View" Calibration Mode:

- Press **CAL** button for 1 second.

NOTE: The audible alarm remains off while in either Calibration Mode except when fine tuning FLOW CAL (where auto control operates).

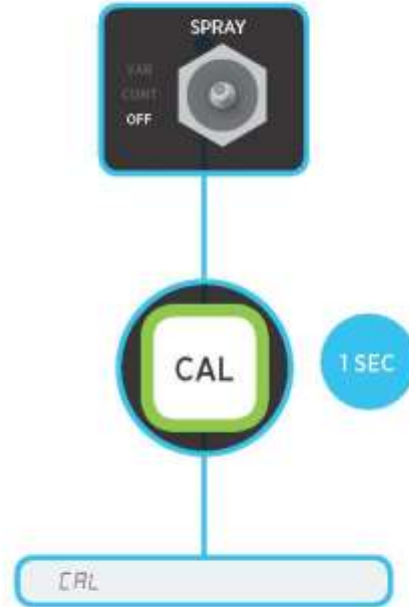

CALIBRATION

SMARTFLOW II FOR BUFFALO TURBINE

Calibration Factors

1. Alarm Setting

The **ALARM SETTING** calibration factor is used to set the delay time for triggering the Audible Alarm*. This delay can be changed from 0 – 6 seconds.

To set the **ALARM SETTING** Calibration Factor:

1. Place the SmartFlow II in Calibration Mode by placing the rotary dial to **TARGET RATE**, and holding the **CAL** and **INC** buttons together until the console reads "SET" and the red Warning LED light is flashing.
2. Move the rotary dial to **ALARM SETTING** position. In the Data display window, the **DELAY SECONDS** are displayed. The Application Rate window displays "ERR".
3. Use the **INC/DEC** buttons to increase or decrease the time.
4. Rotate the rotary dial to **TARGET RATE**. Press and hold the **CAL** button for 3 seconds to save the change and exit Calibration Mode.

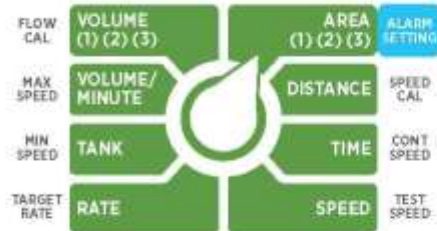

***NOTE:** This delay setting only affects the Audible Alarm, it does not affect any visual alarm (Warning LED). It also does not affect the Tank Alarm (slow beeping) of the Min/Max Speed Alarm (fast beeping).

Example: Whenever there is more than 10% error in the application rate, the Warning LED will turn on (not affected by this setting), but the Audible Alarm will not turn on for another (delay value) seconds. Therefore, if the SmartFlow II has settled on target within (delay value) seconds, the Audible Alarm will not turn on. This temporary delay in sounding the Audible Alarm helps to prevent it from becoming a nuisance alarm (where user may be tempted to shut it off).

Calibration Factors (cont.)

2. Speed Cal

SPEED CAL displays the DISTANCE sensor Calibration Factor in distance traveled between SPEED sensor pulses. It can be changed from 0.001 – 655.36 cm per Edge (rise and fall from pulse to pulse).

To use the GPS data from a tablet or a PC, set SPEED CAL to zero.

To set the SPEED CAL factor:

1. Place the SmartFlow II in Calibration Mode by placing the rotary dial to TARGET RATE and holding the CAL and INC buttons together until the console reads "SET" and the red Warning LED light is flashing.
2. Move the rotary dial to SPEED CAL position. The Data display window will show SPEED sensor pulses. The Application Rate window displays "ERL".
3. Use the INC/DEC buttons to set to zero.
4. Rotate the rotary dial to TARGET RATE. Press and hold the CAL button for 3 seconds to save the change and exit Calibration Mode.

3. CONT Speed

CONT SPEED displays the Continuous Speed value, which can be adjusted from 2.0 – 45.0 mph or km/h. This speed is used for all Application Rates when in the CONTINUOUS mode.

To set the CONT SPEED factor:

1. Place the SmartFlow II in Calibration Mode by placing the rotary dial to TARGET RATE and holding the CAL and INC buttons together until the console reads "SET" and the red Warning LED light is flashing.
2. Move the rotary dial to CONT SPEED position. "SPEED" is displayed in the in the Data display window and the current Continuous Speed is displayed in the Application Rate display window.
3. Use the INC/DEC buttons to increase or decrease the speed.
4. Rotate the rotary dial to TARGET RATE. Press and hold the CAL button for 3 seconds to save the change and exit Calibration Mode.

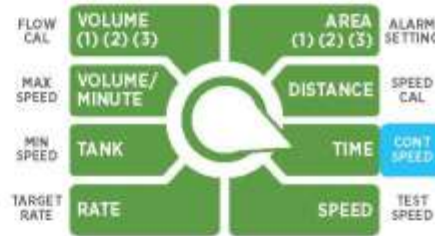
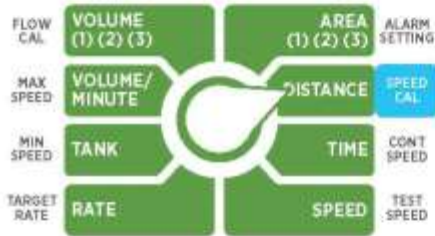

***NOTE:** Using the Garmin Astro-5 Clarke P/N 13621, set SPEED CAL to:

- 0.189 (Yellow loop intact) *only for SmartFlow II
- 0.90 (Yellow loop cut)

Using PC or tablet set SPEED CAL to Zero.

CALIBRATION

SMARTFLOW II FOR BUFFALO TURBINE

Calibration Factors (cont.)

4. Test Speed

TEST SPEED is not a true Calibration Factor, but rather a method of testing the sprayer. Typically, it is used to confirm that **Auto Control** can be maintained across a range of expected ground speeds. The **VARIABLE** mode (on **SPRAY** toggle switch) must be selected because **CONTINUOUS** mode will always use the **CONTINUOUS SPEED** Calibration Factor (instead of **TEST SPEED**). It will display "Go VRR" (go to **VARIABLE**) if the user tries to adjust the test speed while in **CONTINUOUS** mode.

Each time the Calibration Mode is selected (either "View" or "View and Change" Calibration Mode), the test speed will be reset to 0 mph (turned off) so it does not interfere with any other calibration procedures.

To use TEST SPEED:

- Turn the rotary dial to the **SPEED** position and use the **INC** button to adjust it above 0 mph. (Any non-zero test speed will make the **CAL** icon flash. The Warning **LED** light will turn on to remind the user that a **TEST SPEED** is running and the Calibration Mode is no longer fully operating, and therefore the user cannot change any Calibration Factors).
- Normal operating modes will now use the **TEST SPEED** instead of the actual speed input.
- **SPEED** will operate using the **TEST SPEED**. **VOLUME**, **TANK**, **RATE** and **VOLUME/MINUTE** will also operate.
- The **AREA** and **DISTANCE** will not change while in **TEST SPEED** mode. The Application Rate window will show normal data instead of "CRL".
- The Audible Alarm will operate as normal.
- In **VARIABLE** mode, the SmartFlow II will automatically adjust the flow to reach the Target Rate (GPA) based on the **TEST SPEED**.
- In **CONTINUOUS** mode, SmartFlow II will adjust the flow to reach the Target Rate (GPA) based on the **CONTINUOUS SPEED** calibration factor (instead of **TEST SPEED**).

To exit TEST SPEED:

Hold the **CAL** button for 1 second (or turn the SmartFlow II off). The **CAL** icon will stop flashing, the red Warning **LED** will turn off and **TEST SPEED** will be exited. (**TEST SPEED** cannot be turned off by reducing it to 0 because the minimum Test Speed is 0.1 mph.)

While in the **SPEED** position holding the **CAL** and **INC** buttons will not start the **TEST SPEED** mode. This could happen by accident when the user is trying to start the "View and Change" calibration mode, but is accidentally in the **SPEED** position instead of the **RATE** position.

NOTE: If the user changes some Calibration Factors, and then instead of exiting **CAL** mode starts the **TEST SPEED** mode, all Calibration Factors will be stored in **EE** when the user exits **CAL** mode and stops **TEST SPEED** mode.

But, if the user cycles power to stop the **TEST SPEED** mode, then the Calibration Factors will **NOT** be stored.



SMARTFLOW II FOR BUFFALO TURBINE

Calibration Factors (cont.)

5. Target Rate

TARGET RATE displays the Target Application Rate for VARIABLE and CONTINUOUS modes (automatic control). Up to three different Target Rates can be programmed in oz/acre or from mL/hectare. Since a typical rate is 1.00 oz/acre (73.1 mL/Hectare), this provides excellent resolution and range.

The RATE toggle switch (Rate 1, 2 or 3) will determine which target Rate is selected. The number icon (1, 2 or 3) will be displayed in the Application Rate display window.

TARGET RATE is displayed with one or more decimal places depending on the flow rate as shown below. It can range from 0.01 – 99,999.

To set the TARGET RATE factor:

1. Place the SmartFlow II in Calibration Mode by placing the rotary dial to TARGET RATE and holding the CAL and INC buttons together until the console reads "SET" and the red Warning LED light is flashing.
2. Move the rotary dial to TARGET RATE position.
3. Move the RATE 1, 2 or 3 toggle switch to select the Target Rate to be changed.
4. The selected Rate and current units are displayed in the in the Data display window. The current Target Application Rate is displayed in the Application Rate display window.
5. Use the INC/DEC buttons to increase or decrease the rate.
6. Rotate the rotary dial to TARGET RATE. Press and hold the CAL button for 3 seconds to save the change and exit Calibration Mode.

ENGLISH UNITS

When slowly increasing from zero to maximum, the decimal point will automatically shift at the following values:

VALUE	DECIMAL PLACES	RANGE
5	3	0.000 - 1.999
6	2	2.000 - 9.90
7	1	10.0 - 99.0
8	None	100 - 16,777 (and then stops)

When slowly decreasing from maximum to zero, the decimal point will automatically shift at the following values:

VALUE	DECIMAL PLACES	RANGE
5	None	16,777 - 90
3	1	89.9 - 10.0
2	2	9.90 - 1.00
1	3	0.999 - 0.000

Between each of the above 4 decimal ranges, a hysteresis window as shown below will prevent rapid switching back and forth between decimal points.

DECIMAL PLACES	RATE VALUE
2 or 3	1.000 - 1.990
0 or 1	90.0 - 99.9

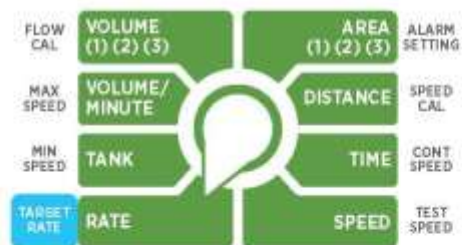

CALIBRATION

SMARTFLOW II FOR BUFFALO TURBINE

Calibration Factors (cont.)

5. Target Rate (cont.)

METRIC UNITS

When slowly **increasing** from zero to maximum, the decimal will shift at the following values:

DECIMAL PLACES	RANGE
1	0,1 – 99,9
None	100 – 99,999 (then goes to OFL)

When slowly **decreasing** from maximum to zero, the decimal will shift at the following values:

DECIMAL PLACES	RANGE
None	99,999 – 99
1	98,9 – 0,1

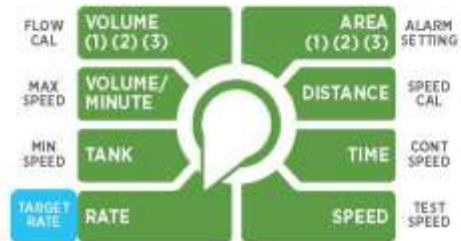

Calibration Factors (cont.)

6. Min Speed

MIN SPEED displays the "Minimum Speed" which can be adjusted from "off" to 0.1 to 45.0 mph or km/h. If used, the user must ensure that Min Speed is less than Max Speed (if used) or else the sprayer will never turn on.

MIN SPEED is used to stop the sprayer (and Distance, Area and Time counting) when the ground speed drops below this limit (in **VARIABLE** mode only).

To set the **MIN SPEED** factor:

1. Place the SmartFlow II in Calibration Mode by placing the rotary dial to **TARGET RATE** and holding the **CAL** and **INC** buttons together until the console reads "SET" and the red Warning LED light is flashing.
2. Move the rotary dial to **MIN SPEED** position. The Data display window displays 'Lo'. The Application Rate display window displays the current Minimum Speed.
3. Use the **INC/DEC** buttons to increase or decrease the Speed.
4. Rotate the rotary dial to **TARGET RATE**. Press and hold the **CAL** button for 3 seconds to save the change and exit Calibration Mode.

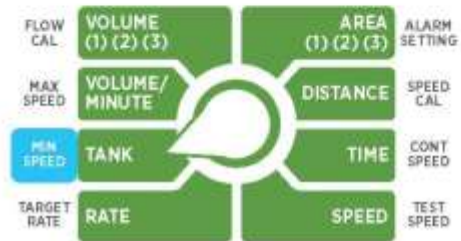

CALIBRATION

SMARTFLOW II FOR BUFFALO TURBINE

Calibration Factors (cont.)

7. Max Speed

MAX SPEED displays the "Maximum Speed" which can be adjusted from "Off" to 0.1 to 45.0 mph or km/h. If used, the user must ensure that **MAX SPEED** is greater than **MIN SPEED** (if used), or else the sprayer will never turn on.

MAX SPEED is used to stop the sprayer (and Distance, Area and Time counting) when the ground speed exceeds this limit (in **VARIABLE** mode only).

To set the **MAX SPEED** factor:

1. Place the SmartFlow II in Calibration Mode by placing the rotary dial to **TARGET RATE** and holding the **CAL** and **INC** buttons together until the console reads "SET" and the red Warning LED light is flashing.
2. Move the rotary dial to **MAX SPEED** position. The Data display window displays "HI". The Application Rate display window displays the current Minimum Speed.
3. Use the **INC/DEC** buttons to increase or decrease the speed.
4. Rotate the rotary dial to **TARGET RATE**, press and hold the **CAL** button for 3 seconds to save the change and exit Calibration Mode.

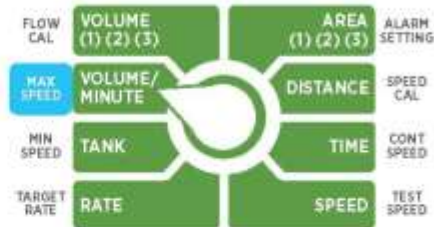

Calibration Factors (cont.)

8. Flow Cal

In the **FLOW CAL** position, the current Flow Meter Calibration Factor value will be displayed. This specifies the number of flow sensor pulses per gallon applied. This enables the SmartFlow II control to accurately measure total flow, flow per minute and application rate. The Flow Meter Calibration Factor is in English or Metric.

To set the **FLOW CAL** factor:

1. Place the SmartFlow II in Calibration Mode by placing the rotary dial to **TARGET RATE** and holding the **CAL** and **INC** buttons together until the console reads "SE T" and the red Warning LED light is flashing.
2. Place the **RATE** toggle switch to **RATE 1**.
3. Move the rotary dial to **FLOW CAL** position.
4. Set the correct Rate* for your product's fluid oz/min per the product label by using the **INC/DEC** buttons. This rate will be displayed in the Application Rate display window.

***HINT:** Choose your fluid oz/min per product label, then divide by 6 to give you your correct Target Rate (oz/acre) at 10 mph to program the console.

5. The selected Rate and current units are displayed in the in the Data display window and the current Target Application Rate is displayed in the Application Rate display window.

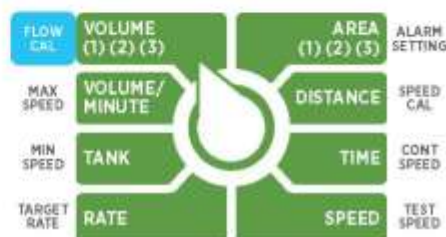

Reloading Calibration Defaults

Default Calibration Factors are loaded, and all Counters are cleared, if the **CAL** and **DEC** buttons are held while turning the SmartFlow II on. If the rotary switch is in the **AREA** position, it will select the Metric Units and load Metric defaults. Any other rotary position will select English units and load English defaults.

CALIBRATION FACTOR	ENGLISH	METRIC
DISTANCE	0	0
AREA 1	0	0
AREA 2	0	0
AREA 3	0	0
GALLONS 1	0	0
GALLONS 2	0	0
GALLONS 3	0	0
TANK	100.0 gal	378.5 L
TIME	0	0
AUDIBLE ALARM DELAY "ALARM SETTING"	3 sec	3 sec
SPEED CAL	0.189 (in/edge)	0.48 (cm/edge)
FLOW CAL (EDGES/OZ)	44.4	44.4
TARGET RATE 1	42.0 oz/acre	30.07 L/hectare
TARGET RATE 2	42.0 oz/acre	30.07 L/hectare
TARGET RATE 3	42.0 oz/acre	30.07 L/hectare
CONTINUOUS SPEED	15.0 mph	24.1 km/h
MIN SPEED	8.0 mph	12.8 km/h
MAX SPEED	20.0 mph	32.19 km/h
UNITS	0 (Eng)	1 (Metric)
VEHICLE ID	1	1
WIDTH	200.0 ft	91.44 m
CONTROL SPEED	-1	-1
TANK SET POINT	10.0 gal	37.9 L
TANK SIZE	100.0 gal	378.5 L
AUTOMATIC SHUTOFF	ON	ON

CALIBRATION

SMARTFLOW II FOR BUFFALO TURBINE

Reloading Calibration Defaults (cont.)

To confirm that defaults were actually loaded, the SmartFlow II will display "LDRd" for at least 1.5 seconds or as long as the CAL or DEC buttons are held, up to 3 seconds. If the CAL and DEC buttons are held for 3 seconds, the display will change to "StorE" and the defaults will be saved to EEPROM. If the CAL and DEC keys are held less than 3 seconds then "StorE" is never displayed and defaults are loaded but not stored in EEPROM.

NOTE: When loading defaults, the TANK value is loaded with the default Tank Size to prevent a Tank Alarm after loading defaults.

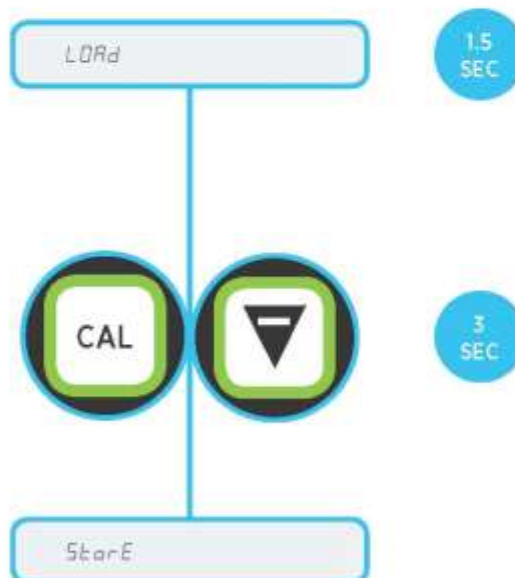

Special Calibration Modes

This section covers these Special Calibration Modes and procedures:

SPECIAL CALIBRATION MODES	41 - 44
1. UNITS	43
2. VEHICLE ID	43
3. WIDTH	43
4. CONTROL SPEED	43
5. TANK ALARM SET POINT	43
6. FILL TANK SIZE	43
7. AUTOMATIC SHUTOFF	44

SMARTFLOW II FOR BUFFALO TURBINE

Special Calibration Modes (cont.)

1. Units

Selecting **AREA** position displays Unit in the Application Rate display and allows the user to change the Units. Pressing the **INC** or **DEC** button will toggle between English and Metric and the Data display will show "EnG" or "mEt".

It is recommended that Units be changed by loading English or Metric defaults because changing the Units calibration factor does not automatically convert other calibration factors. Therefore if the Units are changed, the user must review and change all other calibration factors (like Width) to the correct value for those units. Display will go blank when in an unused **SPECIAL CAL** position.

2. Vehicle ID

Selecting **DISTANCE** position displays "I d" in the Application Rate display and allows the user to change the Vehicle ID from 0 to 255.

3. Width

Selecting **TIME** position displays "UU I dE" in the Application Rate display and allows user to change the Width from 0.1 to 6,553.5 feet or 0.01 to 655.35 meters if Metric.

4. Control Speed

Selecting **SPEED** position displays "C-SPd" in the Application Rate display and allows the user to change the Control Speed for the control algorithm. Pressing the **INC** or **DEC** key will adjust the Control Speed from -4 to 3. It is normally set in the middle (-1) but if needed, it allows the user to decrease or increase the Control Speed for his particular system.

5. Tank Alarm Set Point

Selecting the **VOLUME/MINUTE** position displays "SEEPe" in the Application Rate display and allows the user to change the Tank Alarm Set Point, which can be toggled to **OFF** or set from 0.1 to 6,553.5 Gallons or Liters.

When **OFF**, no alarm will be given as the Tank is emptied. Otherwise a visual and Audible Alarm is given. (See **TANK** section on page 19 for details.)

6. Fill Tank Size

Selecting **VOLUME** position displays "SIZE" in the Application Rate display and allows the user to enter a **FILL TANK SIZE** which can be toggled to **OFF** for 0.1 to 6,553.5 gallons or liters.

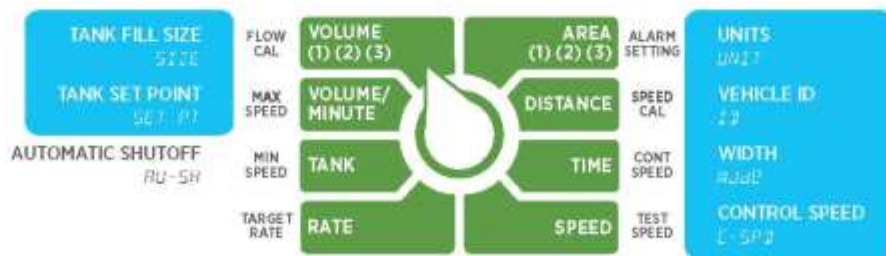

SPECIAL CALIBRATION MODES

SMARTFLOW II FOR BUFFALO TURBINE

Special Calibration Modes (cont.)

7. Automatic Shutoff (AU-SH)

Selecting **TANK** position displays "AU-SH" in the Application Rate display.

When the **SPRAY** switch is turned **OFF**, it fully opens the servo valve and sends the chemical back to the chemical tank.

When the Auto Shutoff (**AU-SH**) is set to **OFF**, the servo valve freezes in whatever position it was in when the **SPRAY** switch was toggled **OFF**. When Auto Shutoff is set to **ON**, the servo valve will completely open when the **SPRAY** switch is toggled **OFF**.

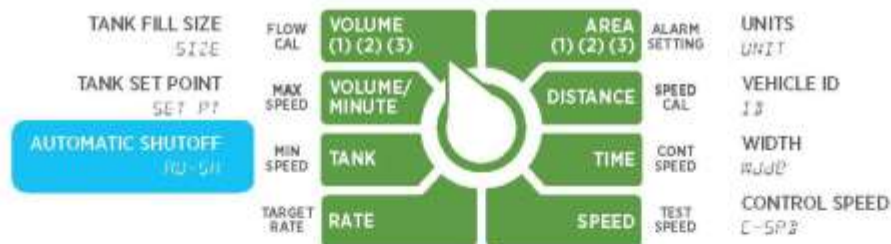

Operation

This section covers these operating procedures:

OPERATION	45 - 51
STARTUP/SHUTDOWN	46
POWER UP MESSAGES	47 - 48
SELECTING APPLICATION RATE	49
CLEARING COUNTERS	50
ADJUSTING TANK VOLUME	51

OPERATION

SMARTFLOW II FOR BUFFALO TURBINE

Startup/Shutdown

Step by Step SmartFlow II Operation

1. Make sure **SPRAY** button is in **OFF** position on the SmartFlow II console.
2. Place **RATE** switch in position (1, 2, or 3).
3. Switch **POWER** switch to **ON** on the SmartFlow II console.
4. Hold **CHOKE** switch up if equipped.
5. Hold **START** switch up until engine starts.
6. When ready to start spraying move **SPRAY** switch to **VAR** or **CONT** located on the console.
7. When done spraying flip **SPRAY** switch to **OFF**.
8. Flush if desired.
9. Flip **POWER** switch to **OFF** position.

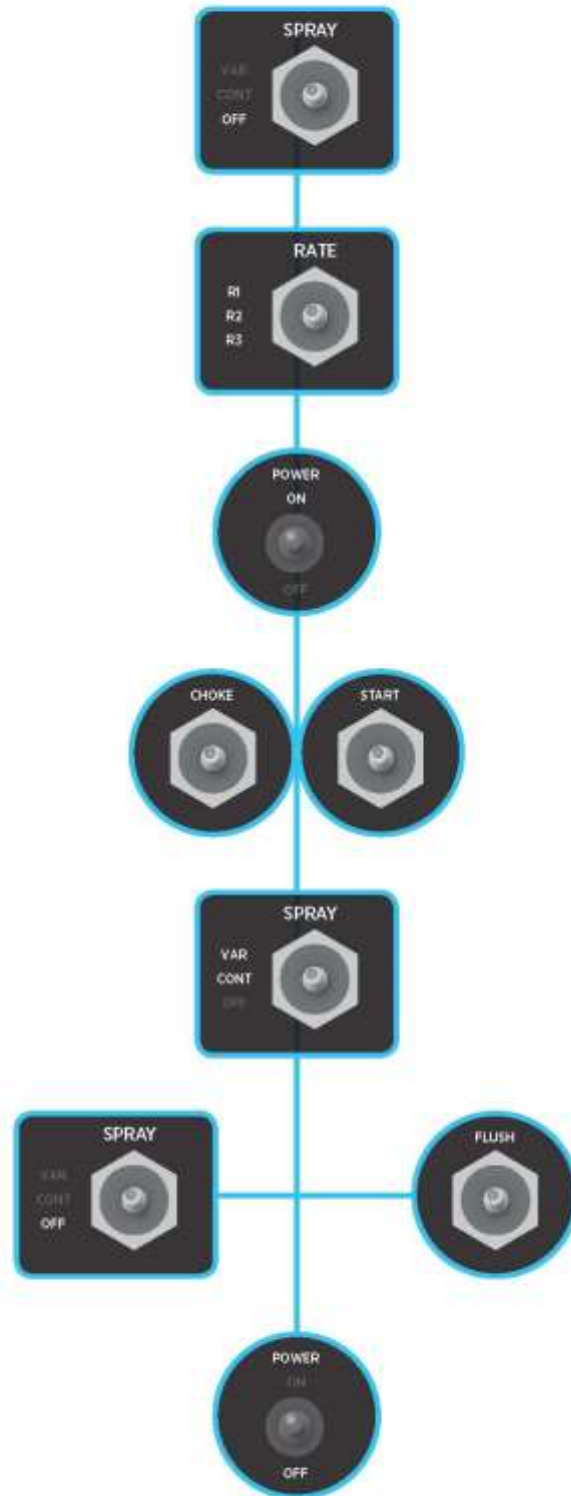

Power Up Messages

When the SmartFlow II is turned on it will give a very short beep and flash the Warning LED to ensure they are working.

It will then display the number of hours it has operated in 0.1 hour increments up to a maximum of 9999.9 hours (then it will display OFL).

9 9 9 9. 9

After one second it will display the Software Part Number for 1.5 seconds. Then, it will display the Software Revision for 1.5 seconds.



OPERATION

SMARTFLOW II FOR BUFFALO TURBINE

Power Up Messages (cont.)

Bad Cal

At power, the SmartFlow II performs a verification of its stored memory (EEPROM). If it detects a problem it will display "bAd CAL" and wait for the user to press the CAL button.

bAd CAL

It will then enter **VIEW ONLY CALIBRATION** and the user should check all the calibration values and the **SPECIAL CAL** factors. The console will remember "bAd CAL" until the user selects the **VIEW CALIBRATION** mode.

Cycling power, etc. will not clear it.



Selecting the Application Rate

To select a preset Application Rate, flip the toggle switch to the desired Rate (1, 2, or 3) and this will be displayed in the Application Rate window.

If the **SPRAY** switch is in the **VAR** or **CONT** position, the selected Rate is displayed.

If the **SPRAY** switch is in the **OFF** position, the upper window will still display **OFF**, but the new application rate will be selected.



Clearing Counters

When **AREA** and **VOLUME 1** (only) are selected, then **RESET** key will clear four counters (Area 1, Volume 1, Distance and Time) at the same time.

When in **OFF** mode, and in the **DISTANCE**, **AREA**, **VOLUME**, or **TIME** rotary position, then pressing the **RESET** key for 1 second will clear Time, Distance, Area 1 and Volume 1 (four counters).

While in **DISTANCE** or **TIME** mode, it will not display or clear any counters unless the counter pair 1 is selected in **AREA** or **VOLUME**. The Area-Volume pairs 2 or 3 are cleared independently.

While in **AREA** or **VOLUME** mode, select the desired pair to clear (2 or 3), and with the **SPRAY** toggle in **OFF** mode press the **RESET** key for 1 second. Since the Area and Volume Counters are paired, clearing a selected Area Counter will also clear the corresponding Volume Counter (and vice versa).

When the **RESET** key is pressed it will immediately display in the Data display as a warning that it is about to clear counters. If the **RESET** key is released while displaying, then the counters remain unchanged. If the **RESET** key is pressed for 1 second or more, then the message disappears and is replaced with "0" to indicate the counters were cleared.

Adjusting Tank Volume

You should adjust the Tank Volume to match the actual volume of pesticide liquid in your tank each time you fill the tank. The **TANK** position (using rotary switch) shows the amount of liquid remaining in the tank, to the nearest tenth of a gallon or liter.

An alarm will be given when the tank level equals or drops below the default Set Point Calibration Factor of 2 gallons, or 7.5 liters, while in **VARIABLE, CONTINUOUS,** or **OFF** mode. This alerts the user that the tank is low whether he is spraying or stopped. (The user can stop the audible and visual Tank Alarm by momentarily pressing the **RESET** button while in any position.)

If a flow signal is present, then **TANK** continues to count down while in the **VARIABLE, CONTINUOUS** or **OFF** mode.

To adjust the tank volume:

1. Make sure that the SmartFlow II control is not in Calibration Mode.
2. The tank volume can be adjusted by setting the **SPRAY** switch **OFF** and then using the **INC** or **DEC** keys to adjust it from 0.0 to gallons or liters. For safety this can only be done while the **SPRAY** switch is in **OFF**.

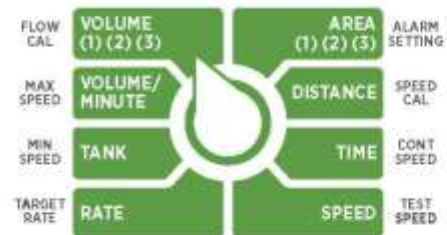

TROUBLESHOOTING

SMARTFLOW II FOR BUFFALO TURBINE

Troubleshooting

This section covers these warning indicators:

TROUBLESHOOTING	52 - 55
ERROR CODES	53 - 55
ERR 1	53
ERR 2	54
ERR 3	55
ERR 4	55
MESSAGES/WARNINGS	56 - 57
NO CONSOLE POWER	57
WARNING LED & AUDIBLE ALARM	57
LOW VOLTAGE DETECTION	57

Error Codes — Err 1

Error Code 1

Pressure is low and there is no spray coming out of the nozzle. This code relates to whether the engine is running at the proper RPM or not.

CONDITION

The Warning **LED** is lit. Audible Alarm beeps, if switched on. The **RED** indicator is lit. Error code is displayed in Application Rate display window. No product is coming out of the nozzle with the Spray Switch in the **CONT** or the **VAR** position.

Typical reasons this error would come up are:

CHECK 1

The engine is not running.

CHECK 2

The Turbine blower is not turning. Check the coupler from the engine to the blower.

CHECK 3

The hose from the nozzle to the pressure switch is damaged, missing or disconnected.

CHECK 4

The wires to the pressure switch have been damaged.

CHECK 5

The pressure switch is bad.

ERROR CODES — ERR 2

In CONT mode, there is no flow signal.

CONDITION

The Warning LED is lit. Audible Alarm beeps (if switched on).

RED indicator is lit.

Error code is displayed in Application Rate display window.

No product is coming out of the nozzle.

CHECK 1

The pump is not turning.

CHECK 2

The pump could be bad.

CHECK 3

The servo valve is not closing.

CHECK 4

The flow meter is malfunctioning.

Error Codes — Err 3

In VAR mode, there is no flow signal

CONDITION

The Warning LED is lit. Audible Alarm beeps, (if switched on.)

RED indicator is lit.

Error code is displayed in Application Rate display window.

No product is coming out of the nozzle.

CHECK 1

The pump is not turning.

CHECK 2

The pump could be bad.

CHECK 3

The servo valve is not closing.

CHECK 4

The Flow Meter is malfunctioning.

Error Codes — Err 4

Flow signal present — SPRAY switch in OFF mode

CONDITION

The Warning LED is lit. Audible Alarm beeps (if switched on).

RED indicator is lit.

Error code is displayed in Application Rate display window. This error is due to the fluid moving back and forth in the flow meter.

NOTE: This is not cause for alarm. Due to the operation of the pump, this is a typical or common condition. As long as there is no spray coming out of the nozzle with the switch off, there is no cause for concern.

TROUBLESHOOTING

SMARTFLOW II FOR BUFFALO TURBINE

Messages and Warnings

The consoles will display the following messages (in alphabetical order) for the conditions indicated:

DISPLAY	CONDITION
<i>bAd CAL</i>	If EEPROM Check Sum equals zero or fails at power up.
<i>CRl</i>	Shown in Application Rate display to help indicate CAL mode is selected.
<i>CLARr</i>	Warning that user is about to clear a counter.
<i>C-SPd</i>	In Application Rate display to indicate the control algorithms CONTROL SPEED in SPECIAL CAL mode is selected.
<i>Err D</i>	Error code in Application Rate display where n = 1 to 5.
<i>FRIL</i>	Failed to reprogram the Flash.
<i>FILL</i>	Flashed in Application Rate display to indicate the tank level is equal or less than Tank Set Point.
<i>FLASH</i>	Console is ready to have the Flash reprogrammed.
<i>FLUSH</i>	In Application Rate display when performing Flush operation.
<i>bDUARr</i>	User is trying to adjust TEST SPEED while in CONTINUOUS mode and needs to "Go to VARIABLE " mode.
<i>HI SPEEDd</i>	In the Application Rate display indicates the ground speed exceeds the MAX SPEED calibration factor while in VARIABLE mode.
<i>Id</i>	In Application Rate display to indicate SPECIAL CAL "Vehicle ID" is selected.
<i>LDRd</i>	User has loaded Default Calibration Factors. (Metric if in AREA mode).
<i>Lo P</i>	Low Power. Low battery voltage.
<i>Lo SPEEDd</i>	In the Application Rate display indicates the ground speed has dropped below the MIN SPEED calibration factor while in VARIABLE mode.
<i>OFF</i>	In Application Rate display when SPRAY toggle switch is in OFF mode.
<i>OFL</i>	Overflow in any display (greater than 99999).
<i>PASS</i>	Correctly finished reprogramming the software.
<i>PCOFF</i>	In Application Rate display when VRA Controller selects PC OFF mode by sending Target = 0.
<i>SEE</i>	User has started "View and Change" CAL mode.
<i>SEEPe</i>	In Application Rate display to indicate SPECIAL CAL TANK "Set Point" is selected.
<i>SPEC</i>	In Application Rate display to indicate SPECIAL CAL mode is selected.
<i>SIzE</i>	In Application Rate display to indicate SPECIAL CAL TANK "Size" is selected.
<i>StorE</i>	Has stored Default Calibration Factors to non-volatile memory.
<i>UnitE</i>	In Application Rate display to indicate SPECIAL CAL "Units" is selected.
<i>WIdE</i>	In Application Rate display to indicate SPECIAL CAL "Width" is selected.

Messages/Warnings: No Console Power

CONDITION

No display or luminance.

CHECK 1

Make sure the main power switch is engaged. Make sure battery is connected and fully charged.

CHECK 2

Disconnect 7 pin cable from console. Measure for voltage between the two larger terminals in the connector (thick **blue** and **orange** wires).

Repair

If voltage is present, reconnect to console.

If voltage not present, see **Check 3**.

CHECK 3

Disconnect 7 wire cable from the machine. Measure for voltage between the two large terminals of the 7 pin connector (thick **blue** and **orange** wires).

Repair

If voltage is present and it was not present for **Check 2**, replace defective cable.

If voltage is not present, see **Check 4**.

CHECK 4

Check the main fuse, located by the battery, to see if the fuse element is melted.

Repair

Replace with same size fuse.

Warning LED & Audible Alarm

While in **VARIABLE** or **CONTINUOUS** mode, the Warning LED, and the Audible Alarm will turn on (steady) whenever there is more than 10% error in the application rate. However the Audible Alarm (only) can be delayed if the **ALARM** Setting is used.

While in **VARIABLE**, **CONTINUOUS**, or **OFF** mode, the Audible Alarm will beep (on and off), the Warning LED will turn on, and the Application display will alternate with the "FILL" message, whenever the **TANK** value is less than the **TANK ALARM SET POINT**.

When in the **VIEW CALIBRATION**, mode the Warning LED does not turn on. When in the "View and Change" **CALIBRATION** mode then the Warning LED will flash, warning that the **INC** and **DEC** keys will change the Calibration Factors.

The Warning LED will flash (warning) when in the Special Calibrate mode and the **INC** and **DEC** keys will change the special Calibration Factors.

The Warning LED will turn on (steady) when in **TEST SPEED** mode.

There are three types of Audible Alarms:

1. A Steady tone indicates a 10% **Rate Alarm**
2. A fast beeping (On/Off) indicates the **Maximum or Minimum Speed** has been exceeded.
3. A slow beeping (On/Off) indicates a **Tank Alarm**.

When all three alarms occur at the same time, the priority is shown above and the Rate Error Alarm will take precedence and the alarm will stay on steady, and the Min/Max Speed Alarm will take precedence over the Tank Alarm.

The Audible Alarm (only) can be turned off (disabled) using the **ALARM ON/OFF** toggle switch on the back of the console.

Low Voltage Detection

When the supply voltage drops below minimum the required operating range, the Data display will display "L α P" (Low Power) and the engine will shut down, but all counters will be stored in **EEPROM**.



GLOBAL HEADQUARTERS

675 Sidwell Court St. Charles, IL 60174 USA Phone: 1 (630) 894-2000

Fax: 1 (630) 443-3070

www.clarke.com

© 2013 Clarke. SmartFlow II is a registered U.S. trademark of Clarke.

062017

OPTIONS TOW BEHIND

NOZZLES

ALUMINUM NOZZLES



Aerospace Polymer Nozzle - Part# 2851
Standard Clamp Band - Part# 1173



Flexible Nozzle Assembly - Part# 3345
Various lengths available.
Ideal for rough terrain.

Gyratory Atomizing Nozzle - Part# 2547
(Safety guard removed for clarity)



Optional aluminum nozzles **will not** connect to the standard Aerospace Polymer Nozzle (Part# 2851). Requires: **Two 45° elbow segments (Part# 1171)** and two additional clamp bands (Part# 1173).

- 12" Nozzle Extension - Part# 1468
- 15" Nozzle Extension - Part# 1842
- 20" Nozzle Extension - Part# 1845

10" Round Nozzle - Part# 1417
12" Round Nozzle - Part# 1172
Improves air velocity with lower horsepower and hydraulic blower units



12" Rectangular Nozzle - Part# 1469
19" Rectangular Nozzle - Part# 1425
55"x15" opening - extra length/more concentrated air flow. Uses - heavy wet debris, plugs, top dressing. **No ground clearance** in the vertical down position.



Fishtail Nozzle - Part# 1743
5"x30" (wide angle) opening. Distributes a large volume of air at a lower velocity over a wide area. Easily converts blower into a "Greens Fan". Adaptable to all models. Not as effective at moving debris.



D.O.T. TRAILER

Part# 1613-D f or 8000, KB4, EFI
Part# 3410 for Mega



2" BALL RECEIVER HITCH

Part# 2981



FORK POCKET

Part# 3894
Great for moving blowers around jobsites and bed mount / skid mount applications.



LINE DRIVER ATTACHMENT

Part# 2419



CORDED CONTROL

Part# 2788 for KB4 Model
Part# 2787 for Mega, Diesel Models



ROTATION BEARING KIT

Part# 3838
Increases rotation speed and reduces load on rotation motor.



EXHAUST GUARD KIT

Part# 2988
Available for Model: KB



BUFFALO TURBINE PRODUCTS

CYCLONE 8000

The Cyclone 8000 Debris Blower is strategically priced to fit most budgets. This little powerhouse is already proving its worthiness in saving Time and Labor.



MEGA

The word "MEGA" is defined as Impressive, Extreme and Mammoth. The NEW Buffalo Turbine MEGA lives up to its name!



CYCLONE PTO

The Cyclone PTO incorporates an "Advanced" direct drive gearbox which significantly reduces routine maintenance. At 238lbs, it's the lightest, meanest turbine style PTO blower available!



CYCLONE SQUARED

The Cyclone Squared with its "Twin Turbines", and wireless controlled dual independent nozzles, in most cases can handle twice the work in half the time. This versatile powerhouse is already a favorite on Golf courses, Racetracks, and the Paving Industry.



CYCLONE KB4

The Cyclone KB4 with its "More Powerful" CH740 Kohler Engine and a "State of the Art" Wireless Remote System is the most powerful KB unit to date.



HYDRAULIC

The Hydraulic debris blower features our built in "flow and pressure" control system and easily attaches to most skid steers. This handy attachment comes complete with mounting plate and hoses.

