

# BUFFALO TURBINE

180 Zoar Valley Road  
Springville, NY 14141

TEL: 716 592 2700 FAX: 716 592 2460

EMAIL: [info@buffaloturbine.com](mailto:info@buffaloturbine.com)

WEBSITE: [www.buffaloturbine.com](http://www.buffaloturbine.com)

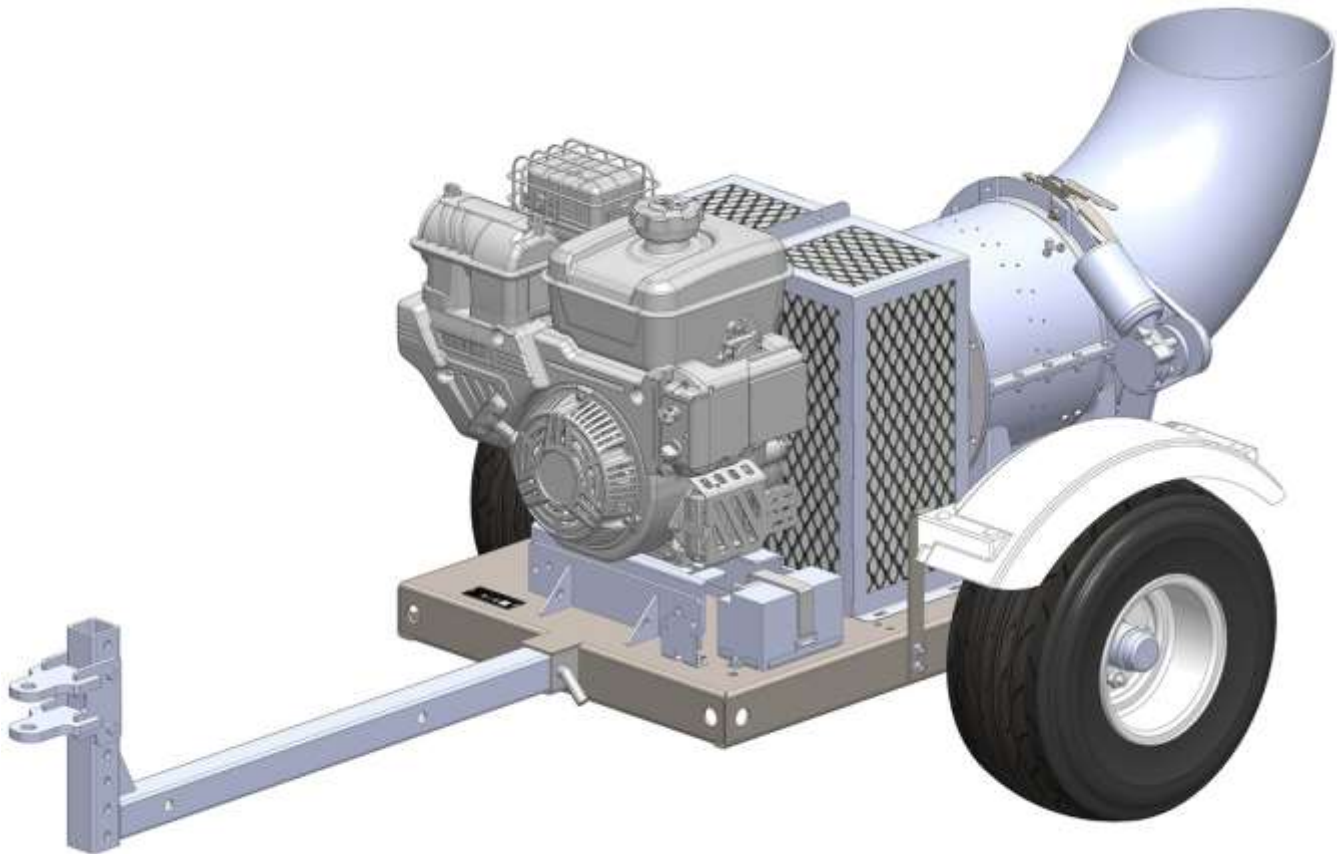

## BUFFALO TURBINE'S BT-CYC8K2CA ORIGINAL INSTRUCTIONS AND PARTS MANUAL

02/26 -BT MAN



## 1.0 INTRODUCTION

Congratulations on your choice of a Buffalo Turbine Debris Blower. This equipment has been designed and manufactured to meet the needs of the Turf Care Industry.

**Safe, efficient and trouble-free operation of your Buffalo Turbine Blower requires that you and anyone else, who will be operating or maintaining the Blower, read and understand all of the safety, operation, maintenance and troubleshooting information contained within this Operator's manual.**

This Manual covers the BT-CYC8K2CA Turbine Blower.

Keep this manual handy for frequent reference and to pass on to new operators or owners. Call your Buffalo Turbine dealer or distributor if you need assistance, information, or additional copies of the manuals.

## SERIAL NUMBER LOCATION

Always give your dealer the serial number of your Debris Blower when ordering parts or requesting service or other information.

The serial number plate(s) is located where indicated in the pictures below. Please document the number in the space provided for easy reference.

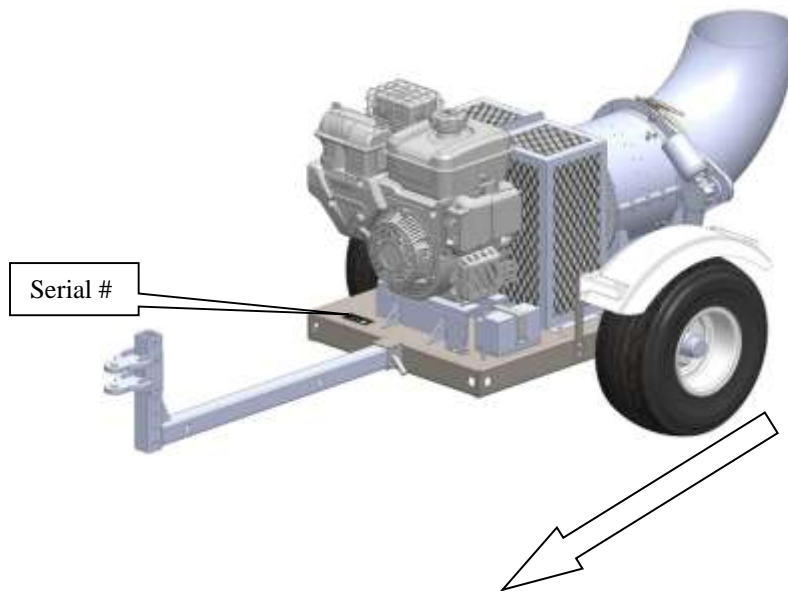

**OPERATOR ORIENTATION** – The directions left, right, front and rear, as mentioned throughout the manual, are as seen from the driver's seat and facing in the direction of travel.

### **MODEL BT-CYC8K2CA** **LEFT FRONT TOP SURFACE OF FRAME**

Serial Number: \_\_\_\_\_

## 2.0 SAFETY

**YOU** are responsible for the **SAFE** operation and maintenance of your Buffalo Turbine Debris Blower. **YOU** must ensure that you and anyone else, who is going to operate, maintain or work around the Buffalo Turbine Blower be familiar with the operating and maintenance procedures and related **SAFETY** information contained in this manual. This manual will take you step-by-step through your working day and alerts you to all good safety practice while operating the Blower.

Remember **YOU** are the key to safety. Good safety practices not only protect you but also the people around you. Make these practices a working part of your safety program. Be certain that **EVERYONE** operating this machine is familiar with the procedures recommended and follows safety precautions. Remember most accidents can be prevented. Do not risk injury or death by ignoring good safety practices.

- Blower owners must give operating instructions to operators or employees before allowing them to operate the Blower, and at least annually thereafter.
- The most important safety device on this equipment is a **SAFE** operator. It is the operator's responsibility to read and understand **ALL** Safety and Operating instructions in the manual and to follow these. All accidents can be avoided.
- A person who has not read and understood all operating instructions is not qualified to operate the machine. An untrained operator exposes themselves and bystanders to possible serious injury or death.
- Do not modify the equipment in any way. Unauthorized modification may impair the function and/or safety which could affect the life of the equipment.
- Think **SAFETY!** Work **SAFELY!**

This Safety Alert symbol means **ATTENTION! BECOME ALERT! YOUR SAFETY IS INVOLVED!**

The Safety Alert symbol identifies important safety messages on the Buffalo Turbine Blower and in the manual. When you see this symbol, be alert to the possibility of personal injury or death. Follow the instructions in the safety message.

Why is **SAFETY** important to you?



**3 Big Reasons: Accidents Disable and Kill  
Accidents Cost  
Accidents Can Be Avoided**

**SIGNAL WORDS:** Note the use of the signal words **DANGER**, **WARNING** and **CAUTION** with the safety messages. The appropriate signal word for each message has been selected using the following guidelines

1. **DANGER** –injury or death if the proper precautions are not taken.
2. **WARNING** -- A specific hazard or unsafe practice that **COULD** result in severe personal injury or death if proper precautions are not taken.
3. **CAUTION** – Unsafe practices that **COULD** result in personal injury if proper practices are not taken, or as a reminder of good safety.

**The Safety Alert symbol identifies important safety messages on the Buffalo Turbine Blower and in the manual. When you see this symbol, be alert to the possibility of personal injury or death. Follow the instructions in the safety message.**

## 2.1 SAFETY DECALS

The types of decals on the blower unit are shown below. Good safety requires that you familiarize yourself with the various Safety Decals, the type of warning and the area, or particular function related to that area that requires your **SAFETY AWARENESS.\* THINK SAFETY! WORK SAFELY!**

### !ATTENTION!

1. **KEEP HANDS, FEET AND CLOTHING AWAY FROM POWER DRIVEN PARTS.**
2. **STOP ENGINE AND REMOVE KEY BEFORE LEAVING OPERATOR'S POSITION.**
3. **MACHINE MUST COME TO A COMPLETE STOP BEFORE ANY MAINTENANCE, TO INCLUDE ADJUSTING, LUBRICATING OR CLEANING, IS PERFORMED.**
4. **KEEP PEOPLE AND PETS AT SAFE DISTANCE FROM MACHINE.**
5. **KEEP ALL GUARDS AND SHIELDS IN PLACE.**

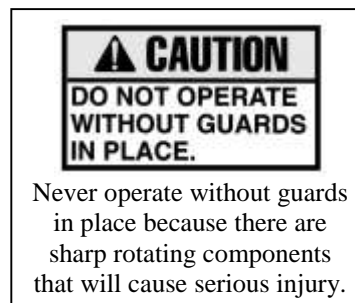
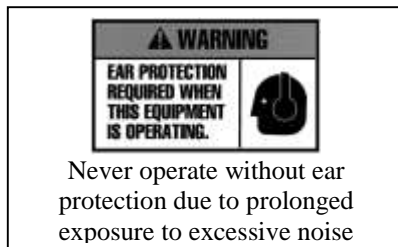
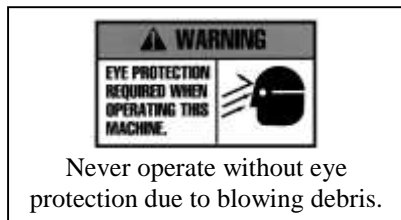

**REMEMBER – If safety decals have been damaged, removed, become illegible or parts replaced without decals, new decals must be applied. New decals are available from your authorized dealer.**

## 2.2 GENERAL SAFETY

1. Read and understand the Operator's Manual and all safety signs before operating, maintaining, and adjusting.
2. Provide a first-aid kit for use in case of an accident. Store in a highly visible place.
3. Provide a fire extinguisher for use in case of an accident. Store in a highly visible place.
4. Wear appropriate protective gear. This list includes but is not limited to:
  - A hard hat
  - Protective shoes with slip resistant soles
  - Protective glasses or goggles
  - Heavy gloves
  - Wet weather gear
  - Hearing protection
5. Do not operate without guards or shields properly installed.
6. Do not allow riders.
7. **Wear appropriate ear protection for prolonged exposure to excessive noise.**
8. **(All Models) Set Blower on the ground, stop engine, set park brake, remove ignition key and wait for all moving parts to stop before dismounting to service or adjust.**
9. Clear the area of people, especially small children, before starting the unit.
10. Review all safety related items annually with all personnel who will be operating or maintaining the Blower.
11. Keep hands, feet, hair and clothing away from moving parts. Operate equipment only while seated in the operator's seat.

## 2.3 OPERATING SAFETY

1. Read and understand the Operator's Manual and all safety signs before operating, servicing or adjusting.
2. Before servicing or repairing, **Set blower on the ground, stop engine, set park brake, remove key, and wait for all moving parts to stop.**

## 2.4 MAINTENANCE SAFETY

1. Read and follow ALL general, operating, maintenance and safety information in this manual.
2. Support the machine with blocks or safety stands when changing tires or working beneath it.
3. Set Blower on the ground, stop engine, set park brake, remove ignition key and wait for all moving parts to stop before operating, servicing or adjusting.
4. Make sure all guards are in place and properly secured when operating or maintaining the Blower.



# Buffalo Turbine Debris Blowers

## Buffalo Turbine Warranty Policy

### 3.0 MACHINE WARRANTY INFORMATION

Buffalo Turbine warrants the DEBRIS BLOWER, to the original owner, to be free from defects in material and workmanship, under normal use and service. **All machines must have a completed registration form sent to Buffalo Turbine within 30 days of purchase for warranty to apply.** Obligation under this warranty shall extend for a period of 10 years from date of purchase and, at the option of Buffalo Turbine, replacement of any parts found, upon inspection by Buffalo Turbine, to be defective. Any parts replaced under warranty will have the remainder of the warranty from the original date of purchase.

**Warranty parts during first 2 years will be shipped free of charge via standard ground shipping**

**\*If expedited shipping is required charges will be paid by the end user\***

Year 1: parts and labor

Year 2: parts only

**Customer will be required to pay shipping charges for years 3-10**

Year 3: Engine, per engine manufacturer's standard / Turbine Assembly / Frame (parts only)

Year 4-10: Turbine Assembly / Frame (parts will be prorated)

**Buffalo Turbine reserves the right to incorporate improvements in material and design of its products without notice and is not obligated to make the same improvements to equipment previously manufactured.**

**ALL WARRANTY REPAIRS NEED PRE-APPROVAL BY A FACTORY PERSON (FROM BUFFALO TURBINE) PRIOR TO COMMENCING WITH A WARRANTY REPAIR TO INCLUDE SERIAL NUMBER AND HOURS FROM HOUR METER (IF EQUIPPED). PRE-APPROVAL WILL BE REQUIRED BY THE END USER AND DEALER/DISTRIBUTOR LEVEL.**

**Factory ordered Buffalo Turbine parts must be used when filing a warranty claim.**

### **LIMITATIONS OF LIABILITY**

This warranty is expressly in lieu of all other warranties expressed or implied and all other obligations or liabilities on our part of any kind or character, including liabilities for alleged representations or negligence. We neither assume nor authorize any other person to assume on our behalf, any liability in connection with the subsequent sale of the **DEBRIS BLOWER**. This warranty shall not apply to any DEBRIS BLOWER, which has been altered outside the factory in any way so as, in the judgment of Buffalo Turbine, to affect its operation or reliability, or which has been subject to misuse, neglect, or accident. This warranty does not cover parts and accessories, which are under separate guarantee from the manufacturers and service can be, obtained from their service facilities. No warranty is extended to regular service items such as lubricants, belts, paint and the like.

### **Original Instruction Manual**

The Purchaser acknowledges having receiving training in the safe operation of the DEBRIS BLOWER and further acknowledges that Buffalo Turbine does not assume any liability resulting from the operation of the DEBRIS BLOWER in any manner other than described in the Operator's Manual supplied at the time of purchase.

**WARRANTY VOID IF NOT REGISTERED (see Page 2 for warranty registration form)**

**DO NOT SPLIT THE TURBINE HOUSING FOR ANY REASON.**

**DO NOT ATTEMPT TO SERVICE OR DISASSEMBLE THE TURBINE BLOWER.**

**DO NOT USE THE TOP OF THE TURBINE HOUSING TO STRAP OR TIE DOWN BLOWER UNITS.**

**Unauthorized service work on the Turbine Blower will null and void all warranties.**

If there are any questions regarding any of our products call Buffalo Turbine at 716 592 2700.

### 3.1 Warranty Registration Form

## BUFFALO TURBINE

### WARRANTY REGISTRATION FORM & INSPECTION REPORT

Any units not registered with Buffalo Turbine are not eligible for warranty claims  
This form must be filled out by the dealer and signed by both the dealer and the customer at the time of delivery

Customer's Name \_\_\_\_\_ Dealer's Name \_\_\_\_\_

Address \_\_\_\_\_ Address \_\_\_\_\_

City, State, Zip, Country \_\_\_\_\_ City, State, Zip, Country \_\_\_\_\_

Email Address (important) \_\_\_\_\_ Email Address \_\_\_\_\_

Telephone Number \_\_\_\_\_

Blower Model \_\_\_\_\_

**Circle one:**

Serial Number \_\_\_\_\_

Commercial Use

Delivery Date \_\_\_\_\_

Private Use

#### DEALER INSPECTION REPORT

#### SAFETY CHECKS

\_\_\_\_\_ Tire Pressure Check -- Model KB

\_\_\_\_\_ All Decals Installed

\_\_\_\_\_ Wheel Bolts

\_\_\_\_\_ Review Operating and Safety Instructions

\_\_\_\_\_ Belt Tension

\_\_\_\_\_ Lubricate Machine

\_\_\_\_\_ Guards in Place

\_\_\_\_\_ Fasteners Tight

\_\_\_\_\_ Trailer assembly bolts properly installed and tightened

#### **ALL 3 POINT HITCH MODELS: PTO SHAFTS MUST TELESCOPE IN EVERY POSITION**

I have thoroughly instructed the buyer on the above described equipment which reviews the included Operator's Manual content, equipment care, adjustments, safe operation and applicable warranty policy.

Date \_\_\_\_\_

Dealer's Rep. Signature \_\_\_\_\_

The above equipment and Operator's Manual has been received by me and I have been thoroughly instructed as to the care, adjustments, safe operation and applicable warranty policy.

Date \_\_\_\_\_

Owner's Signature \_\_\_\_\_

**PLEASE EMAIL TO BUFFALO TURBINE AT - [service@buffaloturbine.com](mailto:service@buffaloturbine.com)**

**Or fax to 716 592 2460**

## 4.0 OPERATIONS

### 4.1 TO THE NEW OPERATOR OR OWNER

Buffalo Turbine Debris Blowers are designed to quickly and efficiently, blow away leaves, cuttings and other debris. The material is conveyed on a stream of high volume and velocity of air to remove it from the area of concern. When the material is removed, it gives a neat, professional look to the working area.

Many of the features incorporated into the machine are the result of suggestions made by customers like you. Read the manual carefully to learn to operate the machine safely and how to set it to provide maximum efficiency. The manual will take you step-by-step through your working day. By following the operating instructions in conjunction with a good maintenance program, your Blower will provide many years of trouble-free service.

#### Potential Mechanical Hazards while operating your machine:

Never operate the debris blower around others to prevent the possibility of being run over by equipment.

Never ride on your debris blower to prevent the possibility of being thrown off the machine or hurt severely.

#### Potential Crushing Hazards while operating your machine:

Between Trailer Tongue and mounting hitch on towing vehicle

Between each nozzle



#### WARNING:

This Product can expose you to chemicals including carbon monoxide and benzene, which are known to the State of California to cause cancer and birth defects or other reproductive harm.

For more information go to [www.P65Warnings.ca.gov](http://www.P65Warnings.ca.gov).

### 4.2 BREAK-IN

Although there are no operational restrictions on the Blower when it is used for the first time, it is recommended that the following mechanical items be checked:

#### A. Operating for first ½ hour

1. Re-torque all wheel bolts, axle nuts and trailer mounting bolts and nuts.
2. Re-torque all other fasteners and hardware.
3. Check set screw (nozzle pulley) to ensure it tightened.

#### B. Operating for first 5 hours

1. Re-torque all hardware and fasteners.
2. Check set screw (nozzle pulley) to ensure it tightened.
3. Go to the normal servicing and maintenance schedule as defined in the Maintenance Section of the manual.

### 4.3 PRE-OPERATION CHECKS

Efficient and safe operation of the Buffalo Turbine Blower requires that each operator reads and understands the operating procedures and all related safety precautions outlined in this section. A pre-operation checklist is provided for the operator. It is important for both personal safety and maintaining the good mechanical condition of the machine that this checklist is followed.

#### BATTERY MUST BE CONNECTED BEFORE OPERATION (DISCONNECTED FOR SHIPPING).

Before Operating the Blower and each time thereafter, the following areas should be checked off.

1. For fuel, oil, and operating information of the Vanguard Engine, refer to the Manufacturers specs included with this manual.
2. The Model CYC8K2 turf trailer is not designed for highway towing. For highway use or speeds above 15mph (24kph) an optional DOT approved trailer must be used.
3. Insure the Blower unit is attached to a proper receiver mounted on the towing vehicle. A pin hitch receptacle is standard with the model CYC8K2. Attach the CYC8K2 trailer using the proper size hitch pin with a locking presto pin.
4. Make sure all guards and shields are in place, secured and functioning as designed.
5. Check that all clamp bands are secure.
6. Check the belts and pulleys for proper tension and alignment.

**CAUTION ! DO NOT ALLOW LEAVES OR DEBRIS TO ACCUMULATE ON OR NEAR THE ENGINE OR EXHAUST SYSTEM OF THE MODEL KB BLOWER, TRACTOR ENGINE OR ANY INTERNAL COMBUSTION ENGINE.**

#### 4.4 MODEL BT-CYC8K2CA Assembly Instructions

1. Fill engine oil to proper level. (overseas shipments)
2. Attach 2 Fender Brackets (part# 5145) with 2 bolts each (part# 4792). Tighten bolts. (REF#1)
3. Attach axle stub shaft assembly (part # 5237) using 2 bolts (part # 4798). Tighten bolts. (REF#2)
4. Attach the tongue (part # 5161) to the frame using the bent hitch pin (part # 5149) and clip pin (part # 5239) Note: The tongue is adjustable and will allow for multiple different heights. Determine the desired height before attaching the tongue. (REF#3)
5. Attach both fenders (part # 1150) using (4) 3/8-16 x 1" carriage bolts (part # 1154) and 3/8-16 flange nuts (part # 4801) (REF#4)
6. Recheck all mounting bolts to assure that they are tight.
7. Bolt on tires(part # 2019) . (REF#2)
8. Reattach positive battery cable (RED) and ground cable (Black) to proper terminals.

**USE PRESTO PIN TO KEEP HITCH PIN IN PLACE WHILE OPERATING**

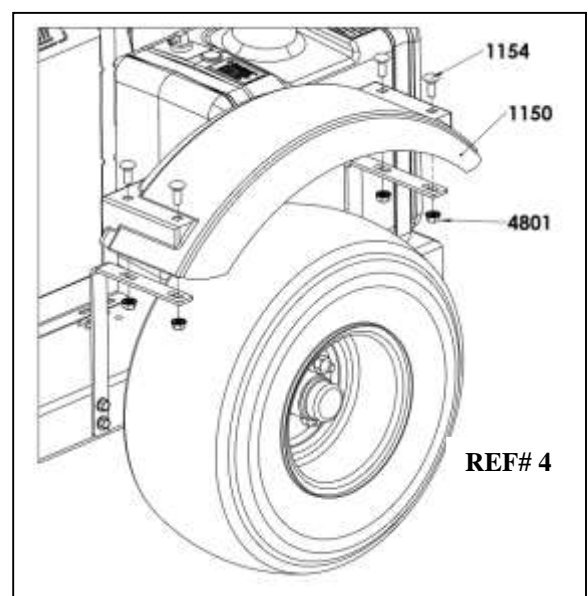
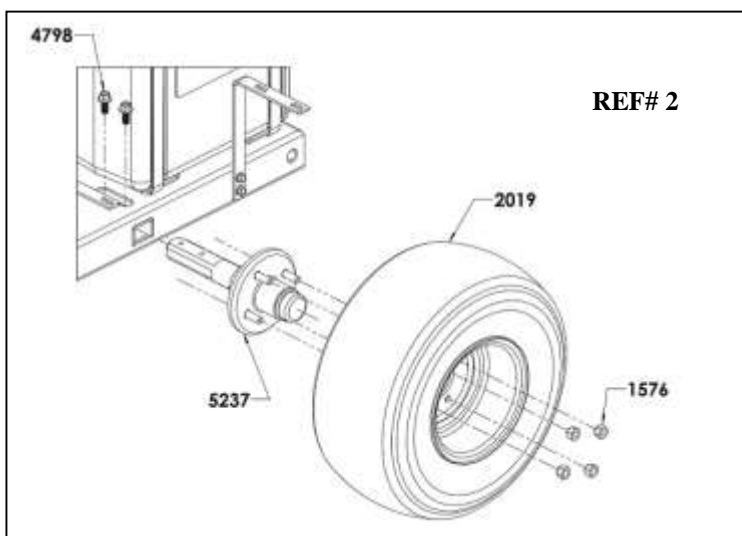
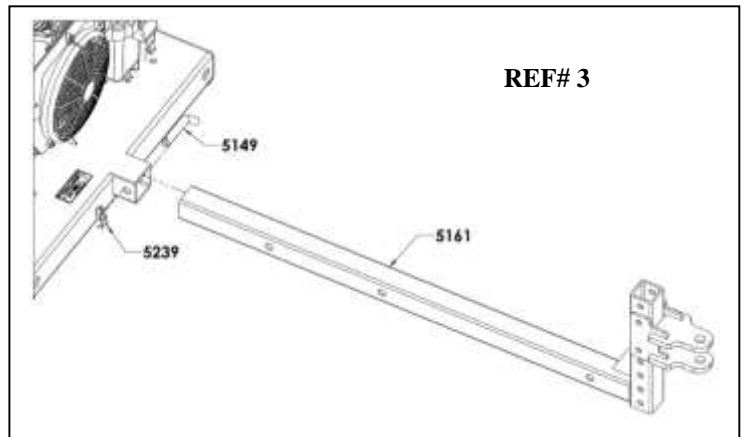
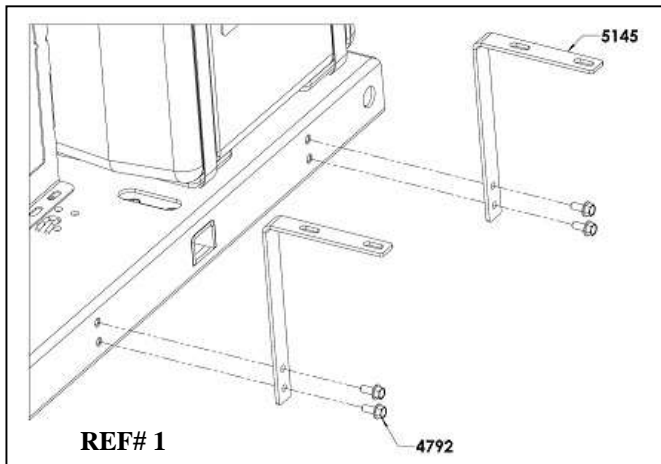

## 4.5 FIELD OPERATION

1. Do not direct debris blower towards people, pets, autos, windows, etc.
2. **Starting blower unit:** Always start engine at a lower engine speed with nozzle pointed down or away. Turn Engine Key to ON position and press Engine Start button on Transmitter.
3. The air stream direction is changed (in either direction) by pressing the nozzle buttons on the transmitter. The nozzle will stop turning by releasing the transmitter button. **ALWAYS CHECK THE GROUND CLEARANCE WHEN OPERATING THE NOZZLE IN THE DOWN VERTICAL POSITION.**
4. **Stopping blower unit:** Shut engine off above ½ throttle by turning key switch to off position to avoid engine backfire. Press Engine Stop button on Transmitter. **Make sure Keyswitch is turned off at the end of the day to prevent battery draining.**
5. Allow the blower fan speed to come to a complete stop before disconnecting from tow vehicle.

## 4.6 OPERATING RPM (ALL MODELS)

The manufacturer's engine section normally recommends the unit be run at a RPM that will insure efficient operation. The Blower can operate at a slower RPM if it can effectively move the debris. Increase engine RPM as needed.

Moving light material, such as dry leaves, requires much less wind than wet or heavier material.

Always try to blow with the wind. The Blower can be used for a wide variety of applications to move leaves, grass clippings, aeration plugs and debris. Drying wet areas has been another use with these powerful Debris Blowers.

## 4.7 STORAGE

At the end of the working season or before storing the blower unit, prepare the machine by following this procedure:

1. Select a storage area that is dry, level and free of debris.
2. Thoroughly wash the machine with a water hose to remove all debris and residue.
3. Run the machine at low RPM to dry the Blower Components.
4. Touch up all paint chips and scratches to prevent rusting.
5. Inspect for worn or failed components. Order the replacement parts and repair the blower unit when time allows. This will eliminate unnecessary down time at the start of next season.
6. Store in an enclosed building. If space is not available, cover with a waterproof tarpaulin and tie it down securely.
7. Store the machine away from areas of human activity.
8. Do not allow children to play around the stored unit.

## 5.0 BT-CYC8K2CA Machine Specifications

<b>Length:</b>	<b>Frame Size 24" wide X 36" Long 94" With nozzle installed and tongue 57.5" Skid model with nozzle installed</b>
<b>Width:</b>	<b>44" With axle and tires</b>
<b>Height:</b>	<b>34" With axle and tires</b>
<b>Weight:</b>	<b>336 lbs</b>
<b>Electrical System:</b>	<b>12 Volt battery / 180 CCA</b>
<b>Fuel Capacity:</b>	<b>1.5 Gallon Unleaded Fuel only</b>
<b>Input Power:</b>	<b>14HP Gas Engine</b>
<b>Outlet Size:</b>	<b>Approximately 10"</b>

## 6.0 MAINTENANCE SECTION

### 6.1 Maintenance Safety

1. Set Blower on a level surface, stop engine, set park brake, remove ignition key and wait for all moving parts to stop before dismounting to service, adjust or repair.
2. Reinstall and secure all guards removed for servicing before starting to use machine again. \*We recommend wearing gloves when removing or installing the guard to avoid getting cut\*
3. Securely support machine with blocks or safety stands when changing tires or working beneath it.

### 6.2 Fluids

Change oil per Manufacturer's specification (see Engine owner's manual section).

### 6.3 SERVICE CHECKLIST

See Lubrication and Maintenance sections for details of service. Copy this page to continue record.

#### **TURN OFF ENGINE, REMOVE KEY & DISCONNECT BATTERY BEFORE SERVICING BLOWER UNIT**

CODE: LUBRICATE-(L) / CHECK-(\*) / CHANGE-(C) / REPLACE-(B) / CLEAN-(CL)

**SCHEDULED MAINTENANCE HOURS** \_\_\_\_\_

**SERVICED BY** \_\_\_\_\_

#### **MAINTENANCE**

##### **8 hrs or daily**

- (\*) Remove all debris that has settled between the blower wheel fan and the stationary vanes. Helps maintain peak performance.
- (\*) Check engine oil and fill to proper level – Do not overfill
- (\*) Check air filter and precleaner
- (CL) Clean debris from air intake and other cooling areas on the engine
- (\*) Check tire pressure (Max. 50 PSI)
- (\*) Check Clamp Band Bolt for tightness

##### **40 hours or weekly**

- (\*) Inspect battery terminals for any corrosion, broken wires, or loose connections.
- (\*) Remove Battery and clean debris from inside of battery box
- (\*) Check set screw (nozzle pulley) to ensure it is tightened
- (\*) Wash and Clean any dirt or grime build up that has accumulated on blower wheel fan blades. Helps to minimize vibration balance and maintain peak performance.

##### **200hrs or annually**

- (CL) Machine

**DO NOT OPERATE BLOWER UNIT WITHOUT GUARDS SECURELY ATTACHED**

# INSTALLATION INSTRUCTIONS & PARTS FOR THE MOREFLEX COUPLING

## PART # 1747 – COUPLING COMPLETE

Includes PN 1110(2pc), 1112(4pc), 1113(4pc), 1114(1pc), 1467(1pc), 1256(1pc), 2869(4pc)

### ALIGNMENT OF TURBINE SHAFT WITH SHAFT OF ENGINE IS CRITICAL

1. Install keys in both shafts.
2. Slide coupling flanges on both shafts (engine and turbine shafts)
3. Place Moreflex coupling CENTER SECTION between coupling flanges and secure with 4 bolts and TOPLOC nuts. The bolt heads are positioned against the coupling in alternating directions. Tighten all 4 bolts. DO NOT TIGHTEN SET SCREWS AT THIS TIME.
4. Check key for proper position under the set screw hole on both shafts.
5. Place several drops of Loctite 271 into these two holes only. Set screws and tapped screw holes must be free of dirt and oil for Loctite to work properly.
6. Install the set screws over the keys and tighten firmly.
7. Using a drill point, dimple each shaft through the other 2 set screw holes. Clean drill chips, oil and dirt before applying Loctite.
8. Place several drops of Loctite 271 in these 2 holes.
9. Install and tighten set screws in these 2 holes.
10. Check and retighten the 4 bolts that hold the coupling center section in place.
11. Visually inspect the unit and replace the guard. DO NOT OPERATE WITHOUT THE GUARDS IN PLACE.

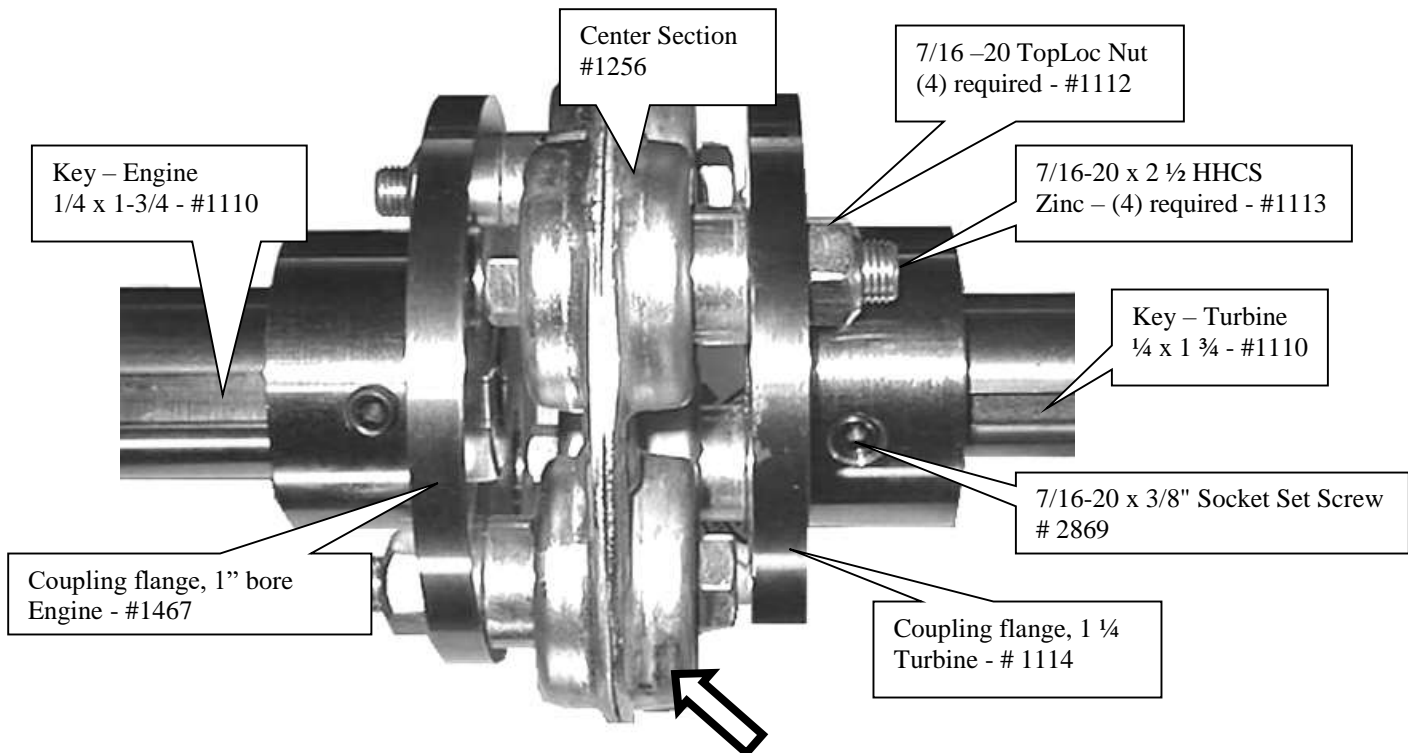

Part # 1256 (center section) is a **“WEAR”** item that should be visually checked each time the engine oil is changed. This coupling is equipped with special lock nuts. Occasionally check that all 4 nuts are securely fastened. **LOOK FOR CRACKS IN THE RUBBER COMPOSITION THAT SURROUNDS THE 4 BUSHINGS. Replace the center section when the rubber composition begins to show ANY signs of cracking OR an increase in vibration OR unusual sounds. When in doubt, call our Service Department.**

## **MOUNTING BLOWER ASSEMBLY ONTO FRAME** **AND ALIGNMENT RECOMMENDATIONS**

1. Install blower assembly onto frame and tighten all of the bolts.
2. Remove all burrs and oil from the shafts and keyways (engine and blower shafts).
3. Using the supplied gauge, align the shafts parallel to each other (very important).
4. Check in four places around the shafts at 90° to each other.
5. When properly aligned, gauge should have little to no gap between itself and the shafts at any point along the gauge.
6. To adjust, move the engine. The 2 mounting brackets have tapped holes in each corner to help support and adjust the position of the engine. The 4 roll pins may need to be repositioned after alignment is completed and bolts are tightened.
7. Tighten all engine bolts and recheck alignment. Drill and install 4 roll pins in new position.

### **ACCEPTABLE**

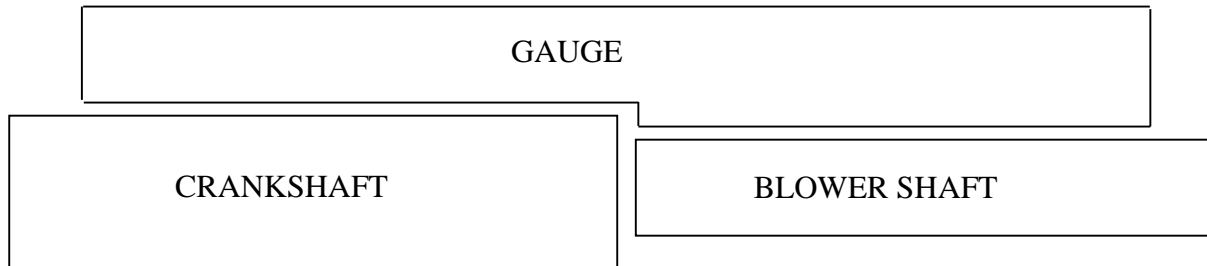

### **NOT ACCEPTABLE**

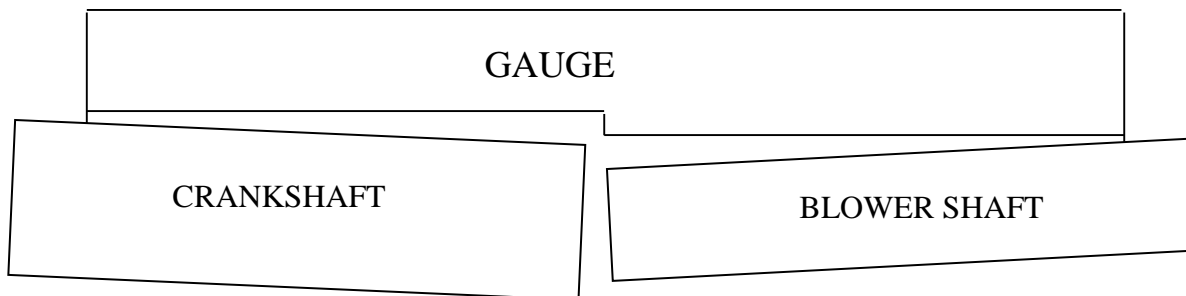

SECURELY ATTACH GUARDS BEFORE OPERATING BLOWER UNITS

# BT-CYC8K2CA PARTS REFERENCE

(BEGINNING W/ SERIAL #42041)

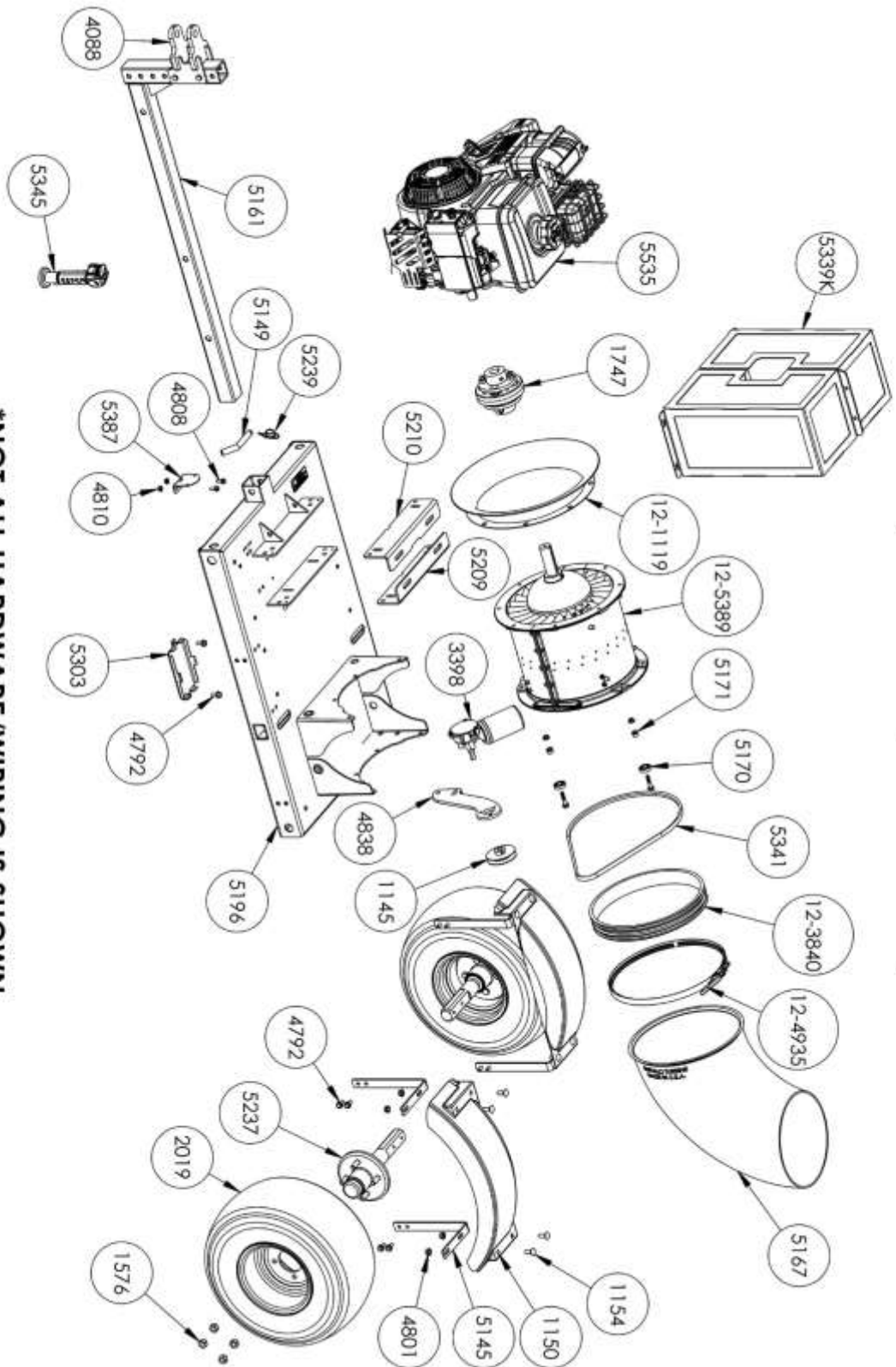

\*NOT ALL HARDWARE/WIRING IS SHOWN

# BT-CYC8K2 SUB ASSEMBLIES PARTS REFERENCE

**PN 1153 (HUB W/ STUD RISERS)**  
REPLACEMENT PARTS

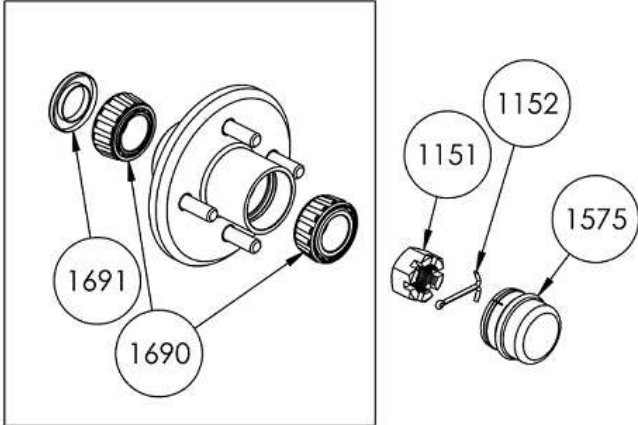

HUB ASSEMBLY PARTS REFERENCE		
Part #	Description	Qty.
1151	1"-14 CASTLE NUT	1
1152	1/8 X 1-1/2" COTTER PIN	1
1575	BEARING CAP	1
1690	1-1/16 TAPER ROLLER BEARING	2
1691	SEAL	1

# WIRING SCHEMATIC JOYSTICK CONTROLLER (PN 5345)

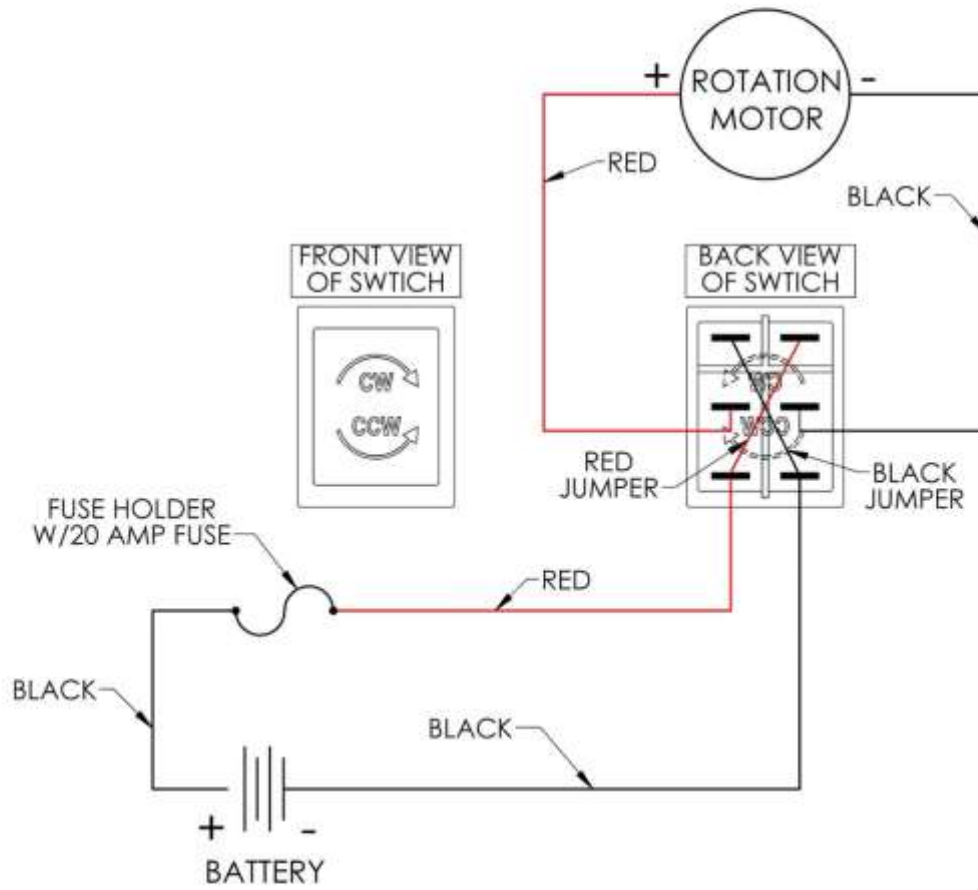





# OPTIONS

180 Zoar Valley Road  
 Springville, NY 14141

## NOZZLES +

## ALUMINUM NOZZLES



Aerospace Polymer Nozzle - Part# 5167

Quick Connect Clamp Band  
 Part# 12-4935

Quickly remove or add nozzle with the barrel style clamp band.



12" Extension - Part# 12-1468  
 20" Extension - Part# 12-1845

**\*Call sales and service to request custom nozzle configuration.**

10" Rectangular Nozzle - Part# 12-1469  
 5.5" x 15" opening - extra length/more concentrated air flow. Uses - heavy wet debris, plugs, top dressing. No ground clearance in the vertical down position.



12" Round Nozzle - Part# 12-1172  
 Improves air velocity with lower horsepower and hydraulic blower units



### CLAMP BAND W/ BOLT & NUT

Part# 12-1173



### 2" BALL RECEIVER HITCH

Part# 4605



### FORK POCKETS

Part# 4552

Great for moving blowers around jobsites and bed mount / skid mount applications.



### CORDED CONTROL

Part# 5579 for 8000EFI Model



**WARNING:**  
 Cancer & Reproductive Harm -  
[www.P65Warnings.ca.gov](http://www.P65Warnings.ca.gov)

# BUFFALO TURBINE PRODUCTS

**Cyclone eKB**



**Cyclone 8000 (& 8000 EFI)**



**Cyclone KB7**



**Cyclone MEGA**



The **Original & Most Powerful**  
**Turbine Debris Blowers**  
since 1945



**BLITZ (& BLITZ MEGA)**



**Cyclone SQUARED**



**Cyclone Hydraulic (& Hydraulic MEGA)**



**Cyclone PTO (& PTO MEGA)**

Visit [BuffaloTurbine.com](http://BuffaloTurbine.com) for more product info