

BUFFALO TURBINE

180 Zoar Valley Road
Springville, NY 14141

TEL: 716 592 2700 FAX: 716 592 2460

EMAIL: info@buffaloturbine.com

WEBSITE: www.buffaloturbine.com

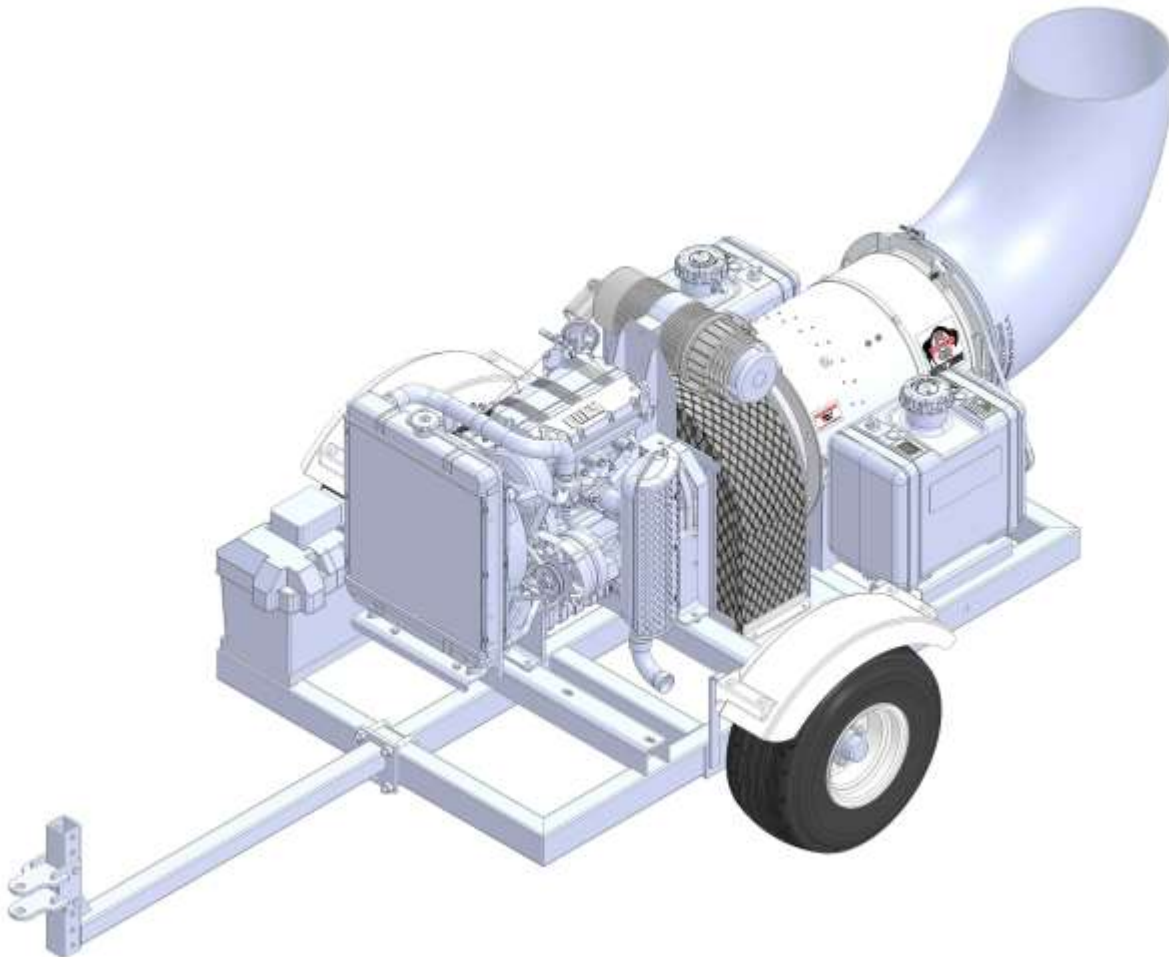

BUFFALO TURBINE'S BT-D1003 ORIGINAL INSTRUCTIONS AND PARTS MANUAL

03/26 -BT MAN

1.0 INTRODUCTION

Congratulations on your choice of a Buffalo Turbine Debris Blower. This equipment has been designed and manufactured to meet the needs of the Turf Care Industry.

Safe, efficient and trouble-free operation of your Buffalo Turbine Blower requires that you and anyone else, who will be operating or maintaining the Blower, read and understand all of the safety, operation, maintenance and troubleshooting information contained within this Operator's manual.

This Manual covers the BT-D1003 Turbine Blower.

Keep this manual handy for frequent reference and to pass on to new operators or owners. Call your Buffalo Turbine dealer or distributor if you need assistance, information, or additional copies of the manuals.

SERIAL NUMBER LOCATION

Always give your dealer the serial number of your Debris Blower when ordering parts or requesting service or other information.

The serial number plate(s) is located where indicated in the pictures below. Please document the number in the space provided for easy reference.

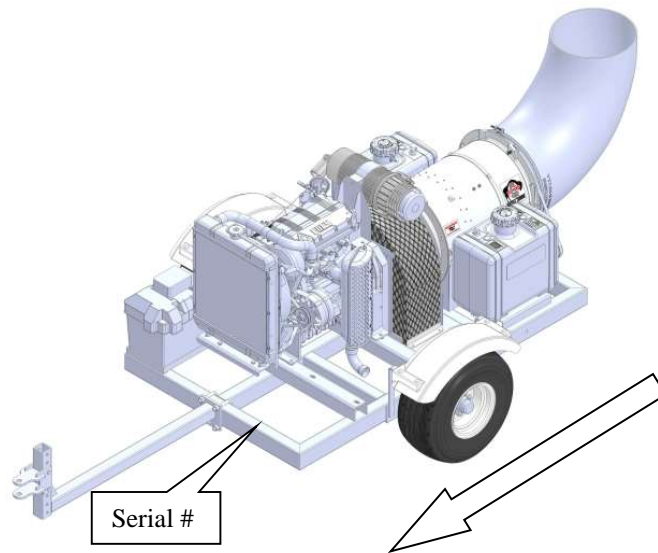

OPERATOR ORIENTATION – The directions left, right, front and rear, as mentioned throughout the manual, are as seen from the driver's seat and facing in the direction of travel.

MODEL BT-D1003 LEFT FRONT TOP SURFACE OF FRAME

Serial Number: _____

2.0 SAFETY

YOU are responsible for the **SAFE** operation and maintenance of your Buffalo Turbine Debris Blower. **YOU** must ensure that you and anyone else, who is going to operate, maintain or work around the Buffalo Turbine Blower be familiar with the operating and maintenance procedures and related **SAFETY** information contained in this manual. This manual will take you step-by-step through your working day and alerts you to all good safety practice while operating the Blower.

Remember **YOU** are the key to safety. Good safety practices not only protect you but also the people around you. Make these practices a working part of your safety program. Be certain that **EVERYONE** operating this machine is familiar with the procedures recommended and follows safety precautions. Remember most accidents can be prevented. Do not risk injury or death by ignoring good safety practices.

- Blower owners must give operating instructions to operators or employees before allowing them to operate the Blower, and at least annually thereafter.
- The most important safety device on this equipment is a **SAFE** operator. It is the operator's responsibility to read and understand **ALL** Safety and Operating instructions in the manual and to follow these. All accidents can be avoided.
- A person who has not read and understood all operating instructions is not qualified to operate the machine. An untrained operator exposes themselves and bystanders to possible serious injury or death.
- Do not modify the equipment in any way. Unauthorized modification may impair the function and/or safety which could affect the life of the equipment.
- Think **SAFETY!** Work **SAFELY!**

This Safety Alert symbol means **ATTENTION! BECOME ALERT! YOUR SAFETY IS INVOLVED!**

The Safety Alert symbol identifies important safety messages on the Buffalo Turbine Blower and in the manual. When you see this symbol, be alert to the possibility of personal injury or death. Follow the instructions in the safety message.

Why is **SAFETY** important to you?



**3 Big Reasons: Accidents Disable and Kill
Accidents Cost
Accidents Can Be Avoided**

SIGNAL WORDS: Note the use of the signal words **DANGER**, **WARNING** and **CAUTION** with the safety messages. The appropriate signal word for each message has been selected using the following guidelines

1. **DANGER** –injury or death if the proper precautions are not taken.
2. **WARNING** -- A specific hazard or unsafe practice that **COULD** result in severe personal injury or death if proper precautions are not taken.
3. **CAUTION** – Unsafe practices that **COULD** result in personal injury if proper practices are not taken, or as a reminder of good safety.

The Safety Alert symbol identifies important safety messages on the Buffalo Turbine Blower and in the manual. When you see this symbol, be alert to the possibility of personal injury or death. Follow the instructions in the safety message.

2.1 SAFETY DECALS

The types of decals on the blower unit are shown below. Good safety requires that you familiarize yourself with the various Safety Decals, the type of warning and the area, or particular function related to that area that requires your **SAFETY AWARENESS. * THINK SAFETY! WORK SAFELY!**

! ATTENTION!

1. **KEEP HANDS, FEET AND CLOTHING AWAY FROM POWER DRIVEN PARTS.**
2. **STOP ENGINE AND REMOVE KEY BEFORE LEAVING OPERATOR'S POSITION.**
3. **MACHINE MUST COME TO A COMPLETE STOP BEFORE ANY MAINTENANCE, TO INCLUDE ADJUSTING, LUBRICATING OR CLEANING, IS PERFORMED.**
4. **KEEP PEOPLE AND PETS AT SAFE DISTANCE FROM MACHINE.**
5. **KEEP ALL GUARDS AND SHIELDS IN PLACE.**

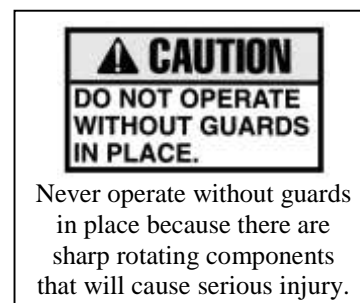
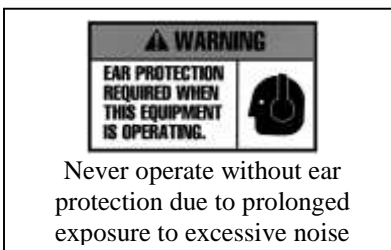
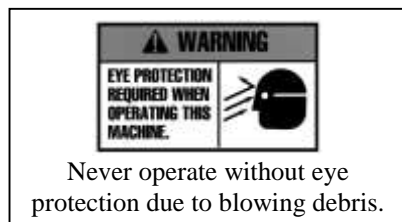

REMEMBER – If safety decals have been damaged, removed, become illegible or parts replaced without decals, new decals must be applied. New decals are available from your authorized dealer.

2.2 GENERAL SAFETY

1. Read and understand the Operator's Manual and all safety signs before operating, maintaining, and adjusting.
2. Provide a first-aid kit for use in case of an accident. Store in a highly visible place.
3. Provide a fire extinguisher for use in case of an accident. Store in a highly visible place.
4. Wear appropriate protective gear. This list includes but is not limited to:
 - A hard hat
 - Protective shoes with slip resistant soles
 - Protective glasses or goggles
 - Heavy gloves
 - Wet weather gear
 - Hearing protection
5. Do not operate without guards or shields properly installed.
6. Do not allow riders.
7. **Wear appropriate ear protection for prolonged exposure to excessive noise.**
8. **(All Models) Set Blower on the ground, stop engine, set park brake, remove ignition key and wait for all moving parts to stop before dismounting to service or adjust.**
9. Clear the area of people, especially small children, before starting the unit.
10. Review all safety related items annually with all personnel who will be operating or maintaining the Blower.
11. Keep hands, feet, hair and clothing away from moving parts. Operate equipment only while seated in the operator's seat.

2.3 OPERATING SAFETY

1. Read and understand the Operator's Manual and all safety signs before operating, servicing or adjusting.
2. Before servicing or repairing, **set blower on the ground, stop engine, set park brake, remove key, and wait for all moving parts to stop.**

2.4 MAINTENANCE SAFETY

1. Read and follow ALL general, operating, maintenance and safety information in this manual.
2. Support the machine with blocks or safety stands when changing tires or working beneath it.
3. Set Blower on the ground, stop engine, set park brake, remove ignition key and wait for all moving parts to stop before operating, servicing or adjusting.
4. Make sure all guards are in place and properly secured when operating or maintaining the Blower.

Buffalo Turbine Warranty Policy

3.0 MACHINE WARRANTY INFORMATION

Buffalo Turbine warrants the DEBRIS BLOWER, to the original owner, to be free from defects in material and workmanship, under normal use and service. **All machines must have a completed registration form sent to Buffalo Turbine within 30 days of purchase for warranty to apply.** Obligation under this warranty shall extend for a period of 10 years from date of purchase and, at the option of Buffalo Turbine, replacement of any parts found, upon inspection by Buffalo Turbine, to be defective. Any parts replaced under warranty will have the remainder of the warranty from the original date of purchase.

Warranty parts during first 2 years will be shipped free of charge via standard ground shipping

If expedited shipping is required charges will be paid by the end user

Year 1: parts and labor

Year 2: parts only

Customer will be required to pay shipping charges for years 3-10

Year 3: Engine, per engine manufacturer's standard / Turbine Assembly / Frame (parts only)

Year 4-10: Turbine Assembly / Frame (parts will be prorated)

Buffalo Turbine reserves the right to incorporate improvements in material and design of its products without notice and is not obligated to make the same improvements to equipment previously manufactured.

ALL WARRANTY REPAIRS NEED PRE-APPROVAL BY A FACTORY PERSON (FROM BUFFALO TURBINE) PRIOR TO COMMENCING WITH A WARRANTY REPAIR TO INCLUDE SERIAL NUMBER AND HOURS FROM HOUR METER (IF EQUIPPED). PRE-APPROVAL WILL BE REQUIRED BY THE END USER AND DEALER/DISTRIBUTOR LEVEL.

Factory ordered Buffalo Turbine parts must be used when filing a warranty claim.

LIMITATIONS OF LIABILITY

This warranty is expressly in lieu of all other warranties expressed or implied and all other obligations or liabilities on our part of any kind or character, including liabilities for alleged representations or negligence. We neither assume nor authorize any other person to assume on our behalf, any liability in connection with the subsequent sale of the **DEBRIS BLOWER**. This warranty shall not apply to any DEBRIS BLOWER, which has been altered outside the factory in any way so as, in the judgment of Buffalo Turbine, to affect its operation or reliability, or which has been subject to misuse, neglect, or accident. This warranty does not cover parts and accessories, which are under separate guarantee from the manufacturers and service can be, obtained from their service facilities. No warranty is extended to regular service items such as lubricants, belts, paint and the like.

Original Instruction Manual

The Purchaser acknowledges having receiving training in the safe operation of the DEBRIS BLOWER and further acknowledges that Buffalo Turbine does not assume any liability resulting from the operation of the DEBRIS BLOWER in any manner other than described in the Operator's Manual supplied at the time of purchase.

WARRANTY VOID IF NOT REGISTERED (see Page 2 for warranty registration form)

DO NOT SPLIT THE TURBINE HOUSING FOR ANY REASON.

DO NOT ATTEMPT TO SERVICE OR DISASSEMBLE THE TURBINE BLOWER.

DO NOT USE THE TOP OF THE TURBINE HOUSING TO STRAP OR TIE DOWN BLOWER UNITS.

Unauthorized service work on the Turbine Blower will null and void all warranties.

If there are any questions regarding any of our products call Buffalo Turbine at 716 592 2700.

3.1 Warranty Registration Form

BUFFALO TURBINE

WARRANTY REGISTRATION FORM & INSPECTION REPORT

Any units not registered with Buffalo Turbine are not eligible for warranty claims
This form must be filled out by the dealer and signed by both the dealer and the customer at the time of delivery

Customer's Name _____ Dealer's Name _____

Address _____ Address _____

City, State, Zip, Country _____ City, State, Zip, Country _____

Email Address (important) _____ Email Address _____

Telephone Number _____

Blower Model _____

Circle one:

Serial Number _____

Commercial Use

Delivery Date _____

Private Use

DEALER INSPECTION REPORT

SAFETY CHECKS

_____ Tire Pressure Check -- Model KB

_____ All Decals Installed

_____ Wheel Bolts

_____ Review Operating and Safety Instructions

_____ Belt Tension

_____ Guards in Place

_____ Lubricate Machine

_____ Trailer assembly bolts properly installed and tightened

_____ Fasteners Tight

ALL 3 POINT HITCH MODELS: PTO SHAFTS MUST TELESCOPE IN EVERY POSITION

I have thoroughly instructed the buyer on the above described equipment which reviews the included Operator's Manual content, equipment care, adjustments, safe operation and applicable warranty policy.

Date _____

Dealer's Rep. Signature _____

The above equipment and Operator's Manual has been received by me and I have been thoroughly instructed as to the care, adjustments, safe operation and applicable warranty policy.

Date _____

Owner's Signature _____

PLEASE EMAIL TO BUFFALO TURBINE AT - service@buffaloturbine.com

Or fax to 716 592 2460

4.0 OPERATIONS

4.1 TO THE NEW OPERATOR OR OWNER

Buffalo Turbine Debris Blowers are designed to quickly and efficiently, blow away leaves, cuttings and other debris. The material is conveyed on a stream of high volume and velocity of air to remove it from the area of concern. When the material is removed, it gives a neat, professional look to the working area.

Many of the features incorporated into the machine are the result of suggestions made by customers like you. Read the manual carefully to learn to operate the machine safely and how to set it to provide maximum efficiency. The manual will take you step-by-step through your working day. By following the operating instructions in conjunction with a good maintenance program, your Blower will provide many years of trouble-free service.

Potential Mechanical Hazards while operating your machine:

Never operate the debris blower around others to prevent the possibility of being run over by equipment.

Never ride on your debris blower to prevent the possibility of being thrown off the machine or hurt severely.

Potential Crushing Hazards while operating your machine:

Between Trailer Tongue and mounting hitch on towing vehicle



WARNING:

This Product can expose you to chemicals including carbon monoxide and benzene, which are known to the State of California to cause cancer and birth defects or other reproductive harm.

For more information go to www.P65Warnings.ca.gov.

4.2 BREAK-IN

Although there are no operational restrictions on the Blower when it is used for the first time, it is recommended that the following mechanical items be checked:

A. Operating for first ½ hour

1. Re-torque all wheel bolts, axle nuts and trailer mounting bolts and nuts.
2. Re-torque all other fasteners and hardware.
3. Check set screw (nozzle pulley) to ensure it tightened.

B. Operating for first 5 hours

1. Re-torque all hardware and fasteners.
2. Check set screw (nozzle pulley) to ensure it tightened.
3. Go to the normal servicing and maintenance schedule as defined in the Maintenance Section of the manual.

4.3 PRE-OPERATION CHECKS

Efficient and safe operation of the Buffalo Turbine Blower requires that each operator reads and understands the operating procedures and all related safety precautions outlined in this section. A pre-operation checklist is provided for the operator. It is important for both personal safety and maintaining the good mechanical condition of the machine that this checklist is followed.

BATTERY MUST BE CONNECTED BEFORE OPERATION (DISCONNECTED FOR SHIPPING).

Before Operating the Blower and each time thereafter, the following areas should be checked off.

1. For fuel, oil, and operating information of the Kohler Engine, refer to the Manufacturers specs included with this manual.
2. The Model KB turf trailer is not designed for highway towing. For highway use or speeds above 15mph (24kph) an optional DOT approved trailer must be used.
3. Insure the Blower unit is attached to a proper receiver mounted on the towing vehicle. A pin hitch receptacle is standard with the model KB. Attach the KB trailer using the proper size hitch pin with a locking presto pin.
4. Make sure all guards and shields are in place, secured and functioning as designed.
5. Check that all clamp bands are secure.
6. Check the belts and pulleys for proper tension and alignment.

Remote Nozzle and Throttle Control

(REFERENCE PAGES 19-25 FOR WIRELESS REMOTE INSTRUCTIONS)

The throttle control adjusts the engine RPM from an idle to maximum RPM and the nozzle control adjusts the rotation of the nozzle assembly (360° in either direction).

CAUTION! DO NOT ALLOW LEAVES OR DEBRIS TO ACCUMULATE ON OR NEAR THE ENGINE OR EXHAUST SYSTEM OF THE MODEL KB BLOWER, TRACTOR ENGINE OR ANY INTERNAL COMBUSTION ENGINE.

4.4 MODEL BT-D1003 Assembly Instructions

1. Fill engine oil to proper level. (overseas shipments)
2. Fill each cell to proper level (Dry Cell Battery) with battery-grade sulfuric acid of 1.265 specific gravity. Battery and acid must be at a temperature of 60°F to 100°F (16°C to 38°C) at the time of filling (overseas shipments).
3. Attach 2 axle weldments (**part# 3155**) with 2 bolts each (**part# 1137**). Do not tighten. (**REF#1**)
4. Tighten 4 axle mount bolts. Use nyloc nuts (part# 1180).
5. Bolt on tires. (**REF#1**)
6. Attach both fenders (part # 1150) using (4) 3/8-16 x 1" carriage bolts (part # 1154), 3/8 lock washer (4) 3/8-16 hex nuts (1155) (**REF#2**)
7. Attach the tongue using the 2 U-bolts (**part # 1707**) and 4 nyloc nuts (**part # 1180**), center on the frame then tighten evenly. Equal pressure must be applied on each hex. **Note: The tongue is adjustable and will allow for multiple different heights. Determine the desired height before attaching the tongue. (REF#3)**
8. Recheck all mounting bolts to assure that they are tight.
9. Reattach positive battery cable (RED) and ground cable (Black) to proper terminals.

USE PRESTO PIN TO KEEP HITCH PIN IN PLACE WHILE OPERATING

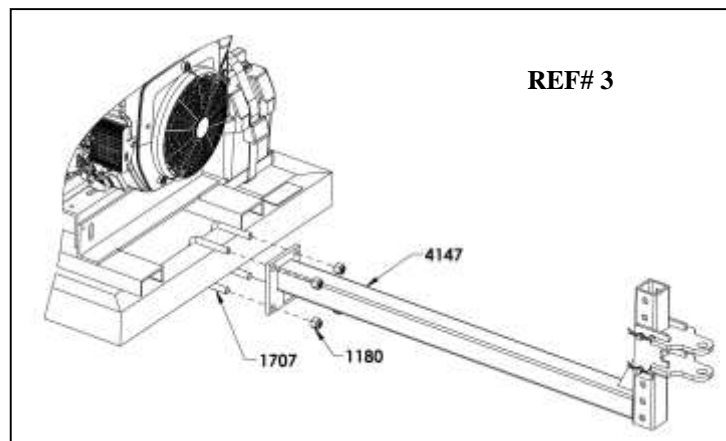
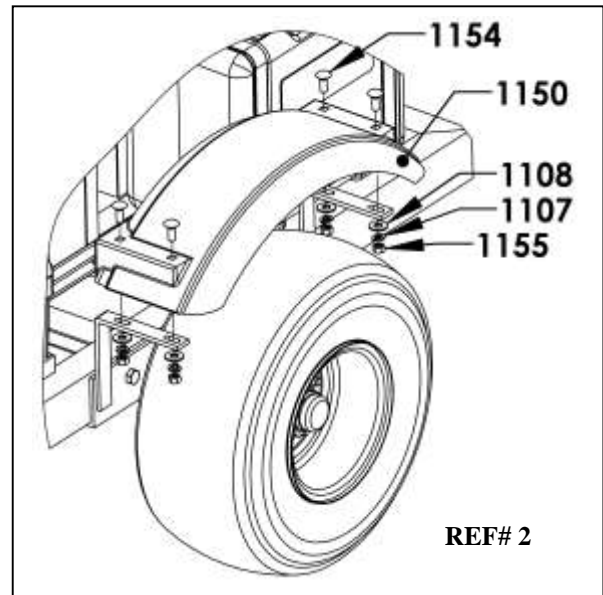
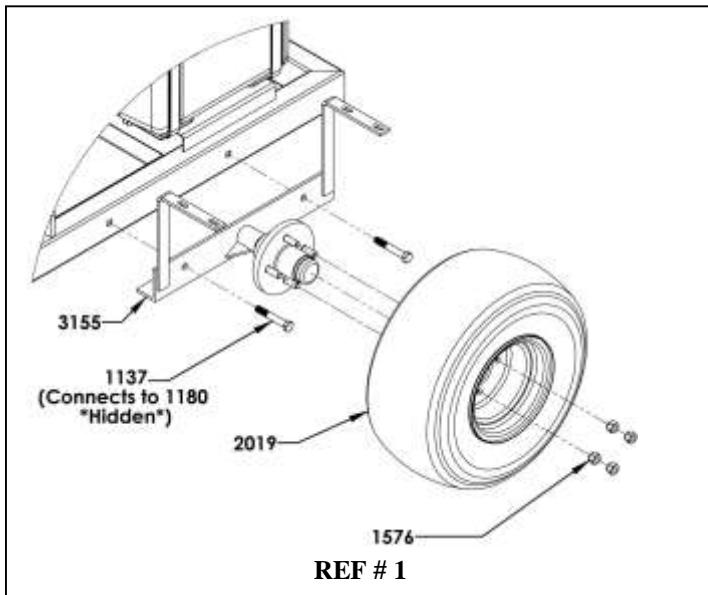

4.5 FIELD OPERATION

1. Do not direct debris blower towards people, pets, autos, windows, etc.
2. **Starting blower unit:** Always start engine at a lower engine speed with nozzle pointed down or away.
3. The air stream direction is changed (in either direction) by pressing the nozzle buttons on the transmitter. The nozzle will stop turning by releasing the transmitter button. **ALWAYS CHECK THE GROUND CLEARANCE WHEN OPERATING THE NOZZLE IN THE DOWN VERTICAL POSITION.**
4. **Stopping blower unit:** Shut engine off above ½ throttle by turning key switch to off position to avoid engine backfire.
5. Allow the blower fan speed to come to a complete stop before disconnecting from tow vehicle.

4.6 Operating RPM (All Models)

The manufacturer's engine section normally recommends the unit be run at a RPM that will insure efficient operation. The Blower can operate at a slower RPM if it can effectively move the debris. Increase engine RPM as needed.

Moving light material, such as dry leaves, requires much less wind than wet or heavier material.

Always try to blow with the wind. The Blower can be used for a wide variety of applications to move leaves, grass clippings, aeration plugs and debris. Drying wet areas has been another use with these powerful Debris Blowers.

4.7 Storage

At the end of the working season or before storing the blower unit, prepare the machine by following this procedure:

1. Select a storage area that is dry, level and free of debris.
2. Thoroughly wash the machine with a water hose to remove all debris and residue.
3. Run the machine at low RPM to dry the Blower Components.
4. Touch up all paint chips and scratches to prevent rusting.
5. Inspect for worn or failed components. Order the replacement parts and repair the blower unit when time allows. This will eliminate unnecessary down time at the start of next season.
6. Store in an enclosed building. If space is not available, cover with a waterproof tarpaulin and tie it down securely.
7. Store the machine away from areas of human activity.
8. Do not allow children to play around the stored unit.

5.0 TROUBLE SHOOTING

The Buffalo Turbine Debris Blower uses a high volume and velocity of air to move material from one place to another. The system is simple and reliable requiring minimal maintenance.

If you encounter a problem that is difficult to solve, even after reading through this trouble shooting section, please call your local dealer or distributor. **Before calling, please have this Operator's Manual and the serial number from your Blower ready.**

In the following section, we have listed causes and solutions to the problems that you may have encountered. **TURN OFF ENGINE, REMOVE KEY, AND DISCONNECT BATTERY BEFORE SERVICING BLOWER UNITS. INSTALL GUARDS BEFORE OPERATING.**

PROBLEM	CAUSE	SOLUTION
No air flow	Buildup of debris inside turbine Broken coupling (KB Series)	Remove nozzle and clean debris from inside turbine Replace coupling
No air flow	Blower fan not turning	See solutions above
Reduced or no air flow	Blower fan turns	Air intake or exhaust restricted Shut off engine Blower or tractor – remove restrictions Debris cannot be allowed to build up between the blower fan and stationary vanes
Machine vibrates or Unusual sounds	Bearing or coupling failure Out-of-balance	Replace bearings or coupling Have your dealer check blower for damaged blades. Wash and clean blower fan blades
No throttle control		See diagnostic tests on pages 22-23
No nozzle control		See diagnostic tests on pages 24-25

6.0 Machine Specifications

Model D1003 Series

Length:	Frame Size 36 1/2" wide X 60" Long 127" With nozzle 103" Without nozzle 86" With nozzle installed but Without trailer arm 62" Without nozzle and trailer arm installed 55" With axle and tires
Width:	38" With axle and tires
Height:	470 lbs.
Weight:	12 Volt battery / 8A24
Electrical System:	12-gallon Diesel Fuel only
Fuel Capacity:	KDW1003 Kohler Engine
Input Power:	Approximately 12"
Outlet Size:	

7.0 MAINTENANCE SECTION

7.1 Maintenance Safety

1. Set Blower on a level surface, stop engine, set park brake, remove ignition key and wait for all moving parts to stop before dismounting to service, adjust or repair.
2. Reinstall and secure all guards removed for servicing before starting to use machine again. *We recommend wearing gloves when removing or installing the guard to avoid getting cut*
3. Securely support machine with blocks or safety stands when changing tires or working beneath it.

7.2 Fluids

Change oil per Manufacturer's specification (see Engine owner's manual section).
A Teflon spray type lubricant on the nozzle base and slides provides for freer rotation.

7.3 SERVICE CHECKLIST

See Lubrication and Maintenance sections for details of service. Copy this page to continue record.

TURN OFF ENGINE, REMOVE KEY & DISCONNECT BATTERY BEFORE SERVICING BLOWER UNIT

CODE: LUBRICATE-(L) / CHECK- (*) / CHANGE-(C) / REPLACE-(B) / CLEAN-(CL)

SCHEDULED MAINTENANCE HOURS _____

SERVICED BY _____

MAINTENANCE

8 hrs. or daily

- (*) Remove all debris that has settled between the blower wheel fan and the stationary vanes. Helps maintain peak performance.
- (*) Check engine oil and fill to proper level – Do not overfill
- (*) Check air filter and precleaner
- (CL) Clean debris from air intake and other cooling areas on the engine
- (*) Check tire pressure (Max. 50 PSI)
- (*) Check Clamp Band Bolt for tightness

40 hours or weekly

- (*) Check condition of coupling (center section # 1256) connecting bolts and nuts during each oil change or when experiencing vibration or unusual noises. (See page 14)
- (*) Inspect battery terminals for any corrosion, broken wires, or loose connections.
- (*) Remove Battery and clean debris from inside of battery box
- (L) Nozzle base slides (Teflon or Silicone spray)
- (*) Check set screw (nozzle pulley) to ensure it is tightened
- (*) Wash and Clean any dirt or grime build up that has accumulated on blower wheel fan blades. Helps to minimize vibration balance and maintain peak performance.

200hrs or annually

- (CL) Machine

DO NOT OPERATE BLOWER UNIT WITHOUT GUARDS SECURELY ATTACHED

INSTALLATION INSTRUCTIONS & PARTS FOR THE MOREFLEX COUPLING

PART # 1746 – COUPLING COMPLETE, KOHLER ENGINE

Includes PN 1110(1pc), 1111(1pc), 1112(4pc), 1113(4pc), 1114(1pc), 1115(1pc), 1256(1pc), 2869(4pc)

ALIGNMENT OF TURBINE SHAFT WITH SHAFT OF ENGINE IS CRITICAL

1. Install keys in both shafts.
2. Slide coupling flanges on both shafts (engine and turbine shafts)
3. Place Morflex coupling CENTER SECTION between coupling flanges and secure with 4 bolts and TOPLOC nuts. The bolt heads are positioned against the coupling in alternating directions. Tighten all 4 bolts. DO NOT TIGHTEN SET SCREWS AT THIS TIME.
4. Check key for proper position under the set screw hole on both shafts.
5. Place several drops of Loctite 271 into these two holes only. Set screws and tapped screw holes must be free of dirt and oil for Loctite to work properly.
6. Install the set screws over the keys and tighten firmly.
7. Using a drill point, dimple each shaft through the other 2 set screw holes. Clean drill chips, oil and dirt before applying Loctite.
8. Place several drops of Loctite 271 in these 2 holes.
9. Install and tighten set screws in these 2 holes.
10. Check and retighten the 4 bolts that hold the coupling center section in place.
11. Visually inspect the unit and replace the guard. DO NOT OPERATE WITHOUT THE GUARDS IN PLACE.

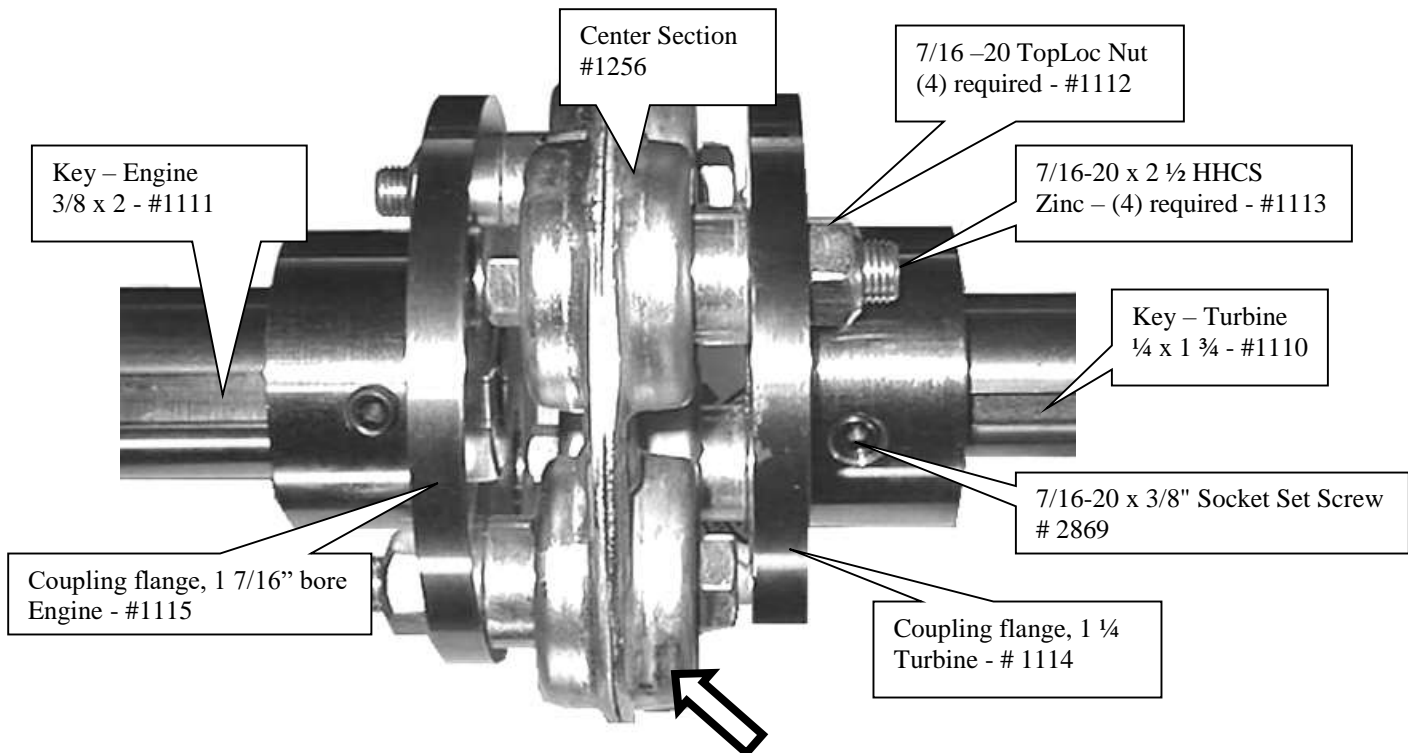

Part # 1256 (center section) is a **“WEAR”** item that should be visually checked each time the engine oil is changed. This coupling is equipped with special lock nuts. Occasionally check that all 4 nuts are securely fastened. **LOOK FOR CRACKS IN THE RUBBER COMPOSITION THAT SURROUNDS THE 4 BUSHINGS. Replace the center section when the rubber composition begins to show ANY signs of cracking OR an increase in vibration OR unusual sounds. When in doubt, call our Service Department.**

MOUNTING BLOWER ASSEMBLY ONTO FRAME **AND ALIGNMENT RECOMMENDATIONS**

1. Install blower assembly onto frame and tighten all of the bolts.
2. Remove all burrs and oil from the shafts and keyways (engine and blower shafts).
3. Using the supplied gauge, align the shafts parallel to each other (very important).
4. Check in four places around the shafts at 90° to each other.
5. When properly aligned, gauge should have little to no gap between itself and the shafts at any point along the gauge.
6. To adjust, move the engine. The 2 mounting brackets have tapped holes in each corner to help support and adjust the position of the engine. The 4 roll pins may need to be repositioned after alignment is completed and bolts are tightened.
7. Tighten all engine bolts and recheck alignment. Drill and install 4 roll pins in new position.

ACCEPTABLE

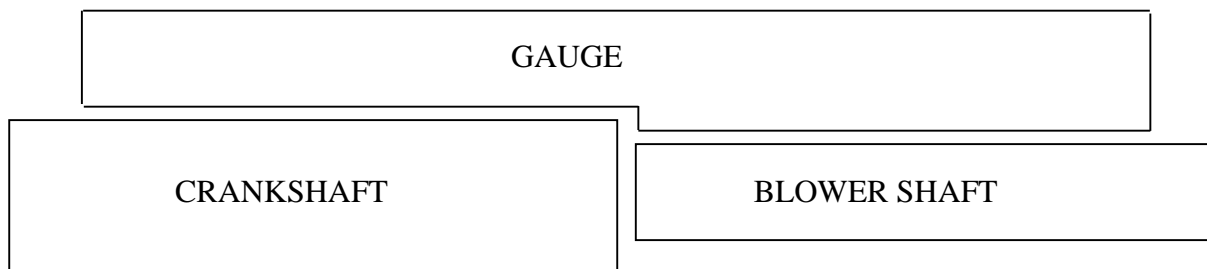

NOT ACCEPTABLE

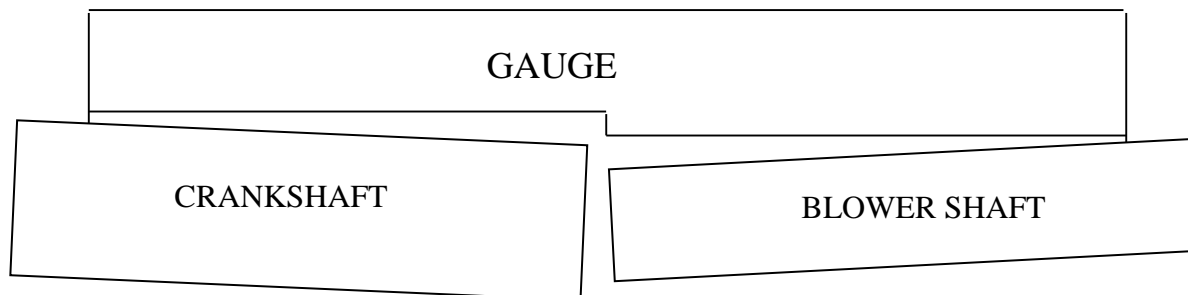

SECURELY ATTACH GUARDS BEFORE OPERATING BLOWER UNITS

BT-D1003 PARTS REFERENCE

(BEGINNING WITH SERIAL #23891)

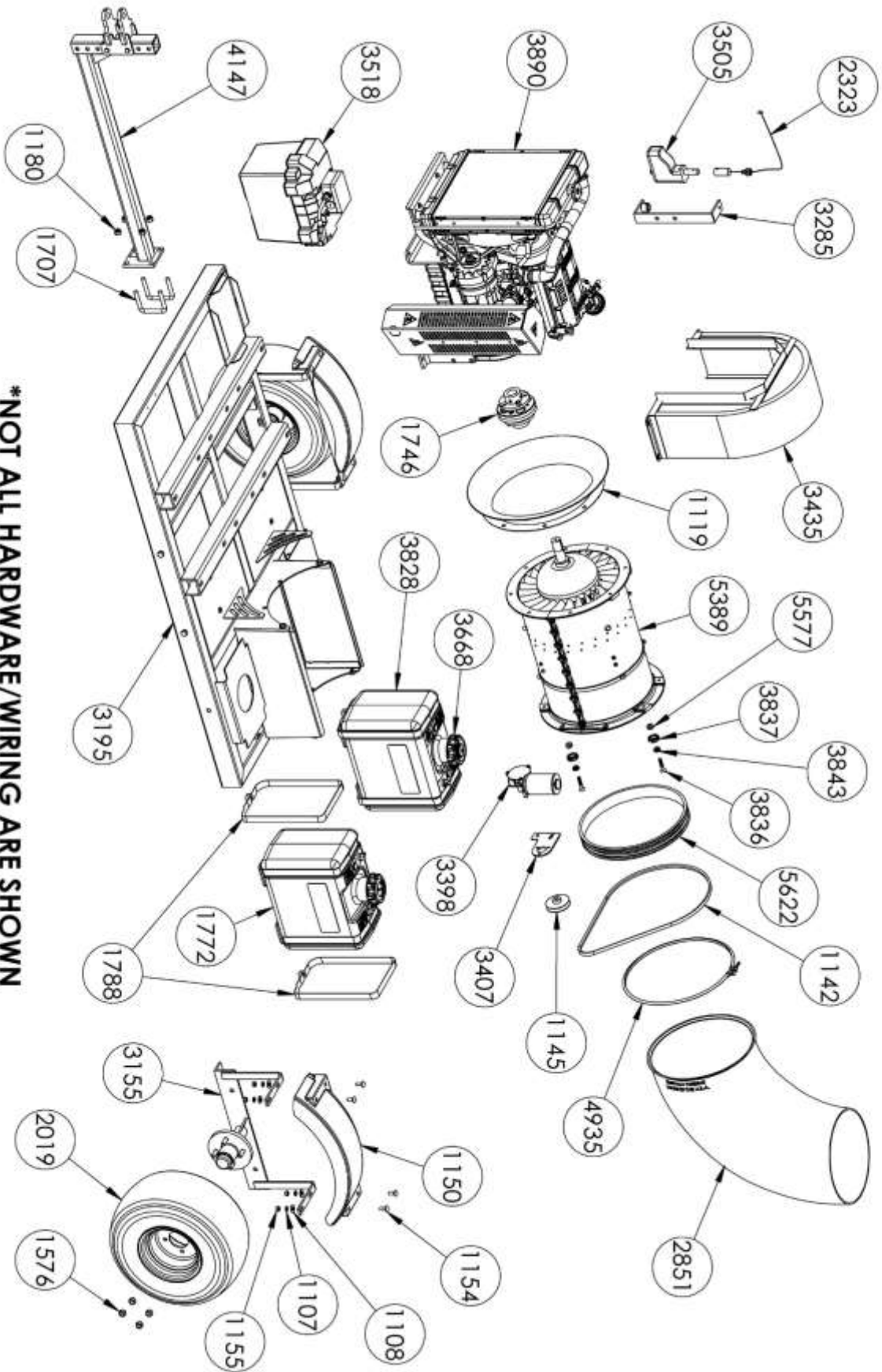

***NOT ALL HARDWARE/WIRING ARE SHOWN**

BT-D1003 SUB ASSEMBLIES PARTS REFERENCE

PN 1153 (HUB W/ STUD RISERS) REPLACEMENT PARTS

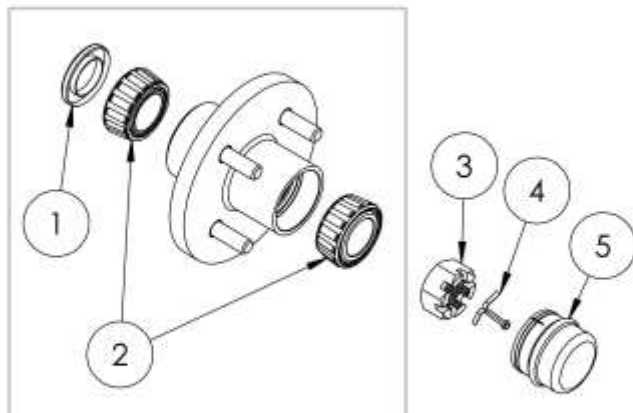

HUB ASSEMBLY PARTS REFERENCE			
Ref #	Qty.	Description	Part #
1	1	SEAL	1691
2	2	1-1/16 TAPER ROLLER BEARING	1690
3	1	1"-14 CASTLE NUT	1151
4	1	1/8 X 1-1/2" COTTER PIN	1152
5	1	BEARING CAP	1575

3518 BATTERY BOX PARTS REFERENCE			
Ref #	Qty.	Description	Part #
6	4	8-32 X 7/8" PHILLIPS PAN HEAD	2306
7	1	UNIVERSAL WIRELESS RECEIVER	3239
8	1	LARGE BATTERY BOX	2259
9	4	8-32 NYLOC NUT	2329
10	1	BATTERY BOX STRAP	3238
11	1	WIRELESS TRANSMITTER	3024

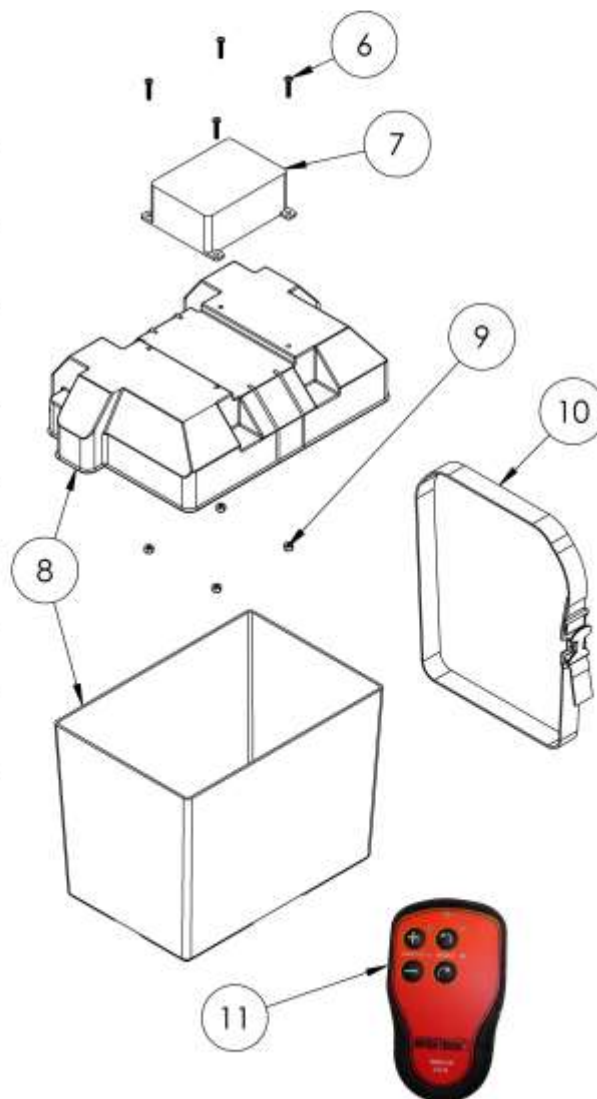

NOTE: NOT SHOWN:
 PART NO: 3512 - WIRING HARNESS, DIESEL
 QTY=1
 PART NO: 2076 - 16/14 FEMALE QUICK DIS.
 QTY=1

BILL OF MATERIALS FOR BT-D1003

REF PAGE #	PN	DESCRIPTION	QTY
	1100	3/8-24 X 1-1/4 HHCS ZINC GR 5	6
	1101	3/8-24 X 1-1/2 HHCS ZINC GRADE 5	7
	1104	3/8-24 X 2 HHCS ZINC GRADE 5	3
	1105	3/8-24 HEX NUT ZINC PLATED GRADE 5	14
	1106	SPACER 3/8 X 3/16 THICK WASHER	1
15	1107	3/8 LOCK WASHER ZINC PLATED	16
15	1108	3/8 FLAT WASHER ZINC PLATED	16
13	1110	KEY, 1/4 X 1-1/2	1
13	1111	KEY, 3/8 X 1-1/2	1
13	1112	7/16-20 TOPLOC NUT GRADE 5 ZINC	4
13	1113	7/16-20 X 2-1/2 HHCS ZINC GRADE 5	4
13	1114	COUPLING FLANGE 1-1/4 BORE	1
13	1115	COUPLING FLANGE 1-7/16 BORE	1
15	1119	14-221-D1 BELLMOUTH	1
	1125	1/4-20 NYLOC NUT	4
	1130	5/16-18 X 3/8 SET SCREW	1
	1137	1/2-13 X 3-1/4 HHCS GRADE 5 ZINC	4
15	1142	AX54 V-BELT	1
15	1145	SHEAVE AK32 X 1/2 (ROTATION MOTOR)	1
15	1150	PLASTIC FENDER	2
15	1154	3/8-16 X 1 CARRIAGE BOLT ZINC	8
15	1155	3/8-16 HEX NUT GRADE 5 ZINC	8
	1156	SERIAL TAG	1
	1158	1/2" GAS LINE	59
	1166	COV 1/2 X 1/4 WIRE CLAMP	4
	1167	COV 5/16 X 1/4 WIRE CLAMP	2
	1168	HC-4M SS HOSE CLAMP	6
	1169	1/4-20 X 1HHCS ZINC	8
	1180	1/2-13 NYLOC NUT ZINC	8
	1194	3/16 X 1-1/2 COTTER PIN	2
13	1256	MOREFLEX CENTER SECTION	1
	1259	1/4 LOCKWASHER	4
	1415	1/4"FLAT WASHER	8
15	1576	1/2-20 LUG NUT	8
	1660	7/16-20 NUT GRADE 5 ZINC	4
	1661	7/16 LOCKWASHER GRADE 5 ZINC	4
	1669	1/4-20 X .055 HEAD INSERT	4
15	1707	U-BOLT	2
13,15	1746	MOREFLEX COUPLING KIT, KOHLER	1
15	1772	FUEL TANK, 6 GALLON BOTTOM DRAW	1
15	1788	GAS TANK STRAP	4
15	2019	18" X 8 1/2" X 8" 4PLY SAWTOOTH TIRE ON 8X7, 4-4 WHITE RIM	2
	2275	79AH SEALED BATTERY 8A24	1
	2320	40" RED BATTERY CABLE	1
15	2323	THROTTLE CABLE ASSEMBLY	1
15	2851	AEROSPACE POLYMER NOZZLE	1
13	2869	7/16-20 X 3/8" SOCKET SET SCREW	4
15	3155	STUB AXLE/HUB ASSEMBLY	2
15	3195	FRAME, BT-D1003	1
15	3285	ACTUATOR BRACKET, LIQUID COOLED DIESEL	1
	3332	3/16"ID FUEL LINE	29
15	3398	ROTATION MOTOR, 12V, BI DIRECTIONAL	1
15	3407	ROTATION MOTOR BRACKET	1
15	3435	GUARD, D1003	1
15	3505	2" SLIDE ACTUATOR	1
15	3518	BATTERY BOX ASSEMBLY, D1003	1
15	3668	DIESEL FUEL CAP	2
15	3828	6 GALLON FUEL TANK, D1003	1
15	3836	3/8-24 X 2" LG FHCS	4
15	3837	ELBOW BASE RING BEARING	4
15	3843	BEARING BUSHING	4
	3881	7/16-20 X 1-1/2 HHCS GR5	4
15	3890	D1003 DIESEL ENGINE (PA-KDW1003-5030BUFF)	1
	4088	HITCH ATTACHMENT WELDMENT	1
	4117	1/2" CLEVIS PIN	2
15	4147	TONGUE ASSEMBLY, ADJUSTABLE	1
	4725	COMBINED WARNING DECAL (EAR/EYE PROTECTION & THROWN OBJECT)	1
15	4935	QUICK ATTACH CLAMP BAND	1
15	5389	RH BLOWER ASSEMBLY	1
15	5577	BEARING SPACER (BACK SIDE OF TURBINE HOUSING)	4
	5588	16" NEGATIVE BATTERY CABLE	1
15	5622	THICK-FLANGE BASE RING KIT (INCLUDES BASE RING, BEARINGS, BUSHINGS AND HARDWARE)	1

BUFFALO TURBINE WIRELESS REMOTE SYSTEM MANUAL FOR BT-D1003

Specifications:

Receiver

(BT PN 3239) WIRELESS RECEIVER for BT-CKB3/BT-CKB4

Transmitter

(BT PN 3024) WIRELESS TRANSMITTER 4 BUTTON

Environmental

Supply Voltage: 12VDC

Signal Analog Voltage Ramp (V/Sec): 10/6

Signal Analog Ramp Range (V): 0-10 increase & 10 - 0 decrease

Functional Relays: functional relays makes/ breaks 8A ACI

Transmit Frequency: 2405-2480 MHz

Number of Freq. Channels: 16

IP Class: IP65

Battery Type: 3 x 1.5 V - AAA alkaline

Operating Time: Approx. 15 h. with continuous usage

Operation

Operation of the controlled device is performed with the Nozzle and Throttle buttons on the transmitter. The Nozzle buttons are used to rotate the Nozzle clock (⌚) wise or counter clock wise (⌚). The Throttle buttons (+) increase and (-) decrease the engines throttle.

- Analog Signal Ramp Range (DCV): 0 to 10 increase (+) / 10 to 0 decrease (-)
- Releasing the + or - buttons at any time during an increase/decrease command will result in the control voltage to remain at a proportional value between 0 and 10 volts.
- At any time, the operator can press both + and - buttons simultaneously to return the variable output to 0 volts resulting in the engine's throttle be set back to low idle.

Pairing Transmitter (TX) to Receiver (RX)

This procedure should be used to pair a single transmitter to the receiver. If you need multiple transmitters paired to this Receiver Contact Buffalo Turbine at 716-592-2700 for assistance.

The following steps will completely erase any previously stored transmitter out of the receiver's memory making them obsolete. You have 10 seconds to complete these procedures after turning the engine key switch to the run position.

1. Verify that the transmitter has a green light when each individual button is pressed.
2. Engine key switch should be in the "OFF" position.
3. Switch on the back of the Transmitter needs to be in "ON" Position.
4. Firmly press and hold transmitter buttons Throttle +, Throttle -, and Nozzle 1 CCW (⌚) simultaneously.
5. While holding down the three buttons, turn the engine key switch ON, supplying power to receiver.
6. Keep holding down these three buttons for 6-10 seconds in which time the nozzle should start to move.
7. Pairing has been successfully completed.

If a valid code from an already registered TX is received, the receiver will go directly into normal operating mode. This is to speed up the startup time.

NOTE: Breaking any warranty seal will void the equipment's warranty, consult with Buffalo Turbine at 716-592-2700 before proceeding.

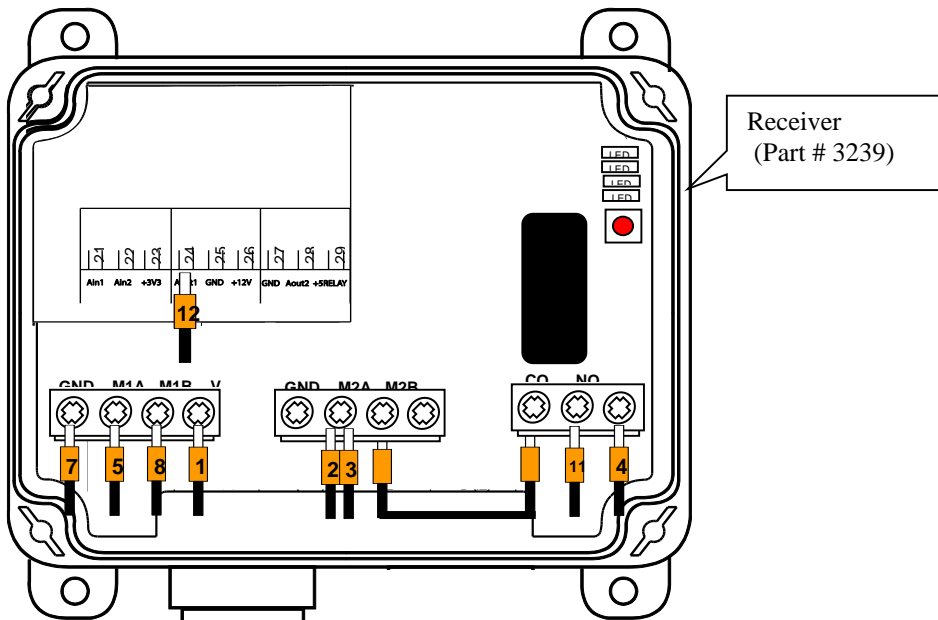

Wire #	Function	Terminal number
1	+12VDC (Yellow)	4
7	-0VDC, Ground (Black)	1
5	Throttle relay (Green)	12
8	Throttle relay (Purple)	15
3	Nozzle 1 (Gray)	6
4	Nozzle 1 (White)	9

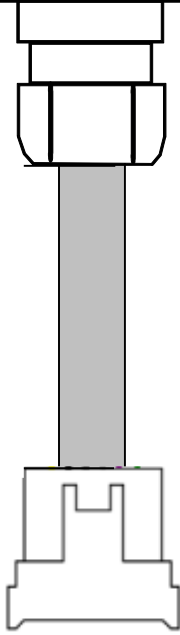

Wiring Schematic for Wireless system

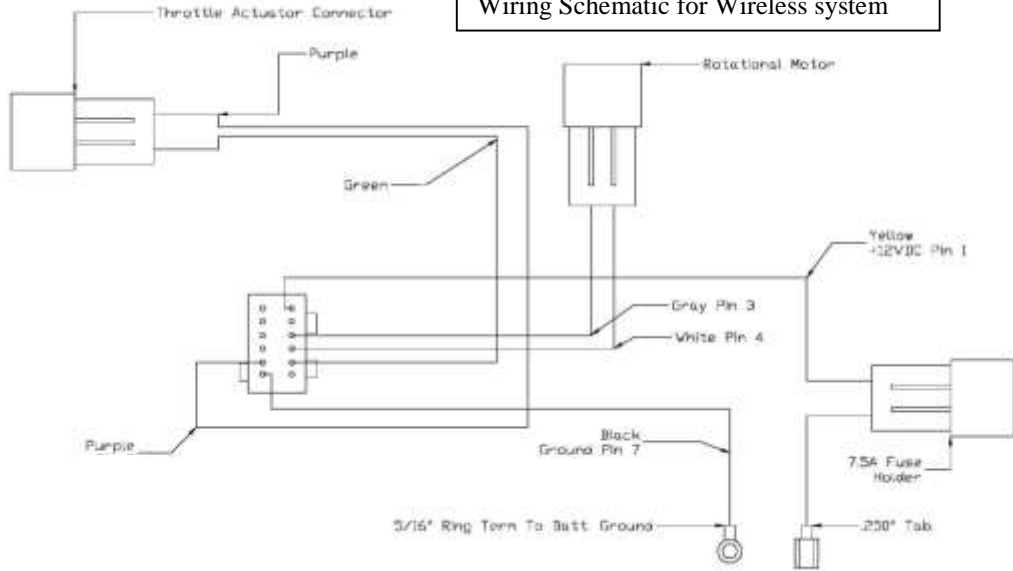

BATTERIES

BATTERY TYPE: 3 x 1.5 V

AAA alkaline

OPERATING TIME: Approx. 15 h. with continuous usage

WARNING! Do not recharge! Attempts to recharge may cause rupture, or the leaking of hazardous liquids which will corrode the equipment.

CHANGE THE BATTERIES

1. Remove the clip (2 screws).
2. Remove the battery cover (2 screws).
3. Remove the batteries, starting with the one in the middle.
4. Put the new batteries in (3 x 1.5V AAA batteries), starting with the battery to the left or to the right.
5. put back the battery cover (2 screws).

BATTERY PRECAUTIONS

Observe the following warnings.

- As batteries contain flammable substances such as lithium or other organic solvents, they may cause heating, rupture or ignition.
- Risk of explosion if battery is replaced with a battery of an incorrect type.
- Do not short circuit, disassemble, deform or heat batteries.
- Never try to charge a visibly damaged or frozen battery.
- Do not charge rechargeable batteries with a higher voltage than specified.
- Keep batteries out of reach of small children. Should a child swallow a battery, consult a physician immediately.
- Avoid direct soldering to batteries.
- When discarding batteries, insulate the + and - terminals of batteries with insulating/ masking tape. Do not put multiple batteries in the same plastic bag.
- When improperly disposed, lithium batteries may short circuit, causing them to become hot, burst or ignite.
- Store in a cool location. Keep batteries away from direct sunlight, high temperature, and high humidity.
- Do not throw batteries into fire.

DISPOSAL OF BATTERIES AND ELECTRONICS

An alkaline battery does not contain mercury, cadmium or lead, and is better for the environment than older types of batteries. Alkaline batteries should be disposed through local recycling stations/waste dumps. Contact your local government's recycling or solid waste department for more information on proper recycling of alkaline batteries in your region.

Improperly disposed batteries and electronics may harm public health and the environment. Batteries and electronic waste may contain toxic heavy metals. If thrown away in the trash, the toxic compounds can leach into soil and water, pollute lakes and streams, making them unfit for drinking, swimming, fishing, and wildlife. Contact your local government's recycling or solid waste department for more information on proper disposal of batteries and electronics in your region.

GUARANTEE, SERVICE, REPAIRS AND MAINTENANCE FOR WIRELESS SYSTEM

Buffalo Turbine products are covered by a guarantee against material, construction and manufacturing faults. During the guarantee period, Buffalo Turbine may replace the product or faulty parts. Work under guarantee must be authorized by Buffalo Turbine.

The following is not covered by the guarantee: Faults resulting from normal wear and tear, parts of a consumable nature, any Product that has been subject to unauthorized modifications, a faults resulting from incorrect installation or use, and any failure due to damp and/or water damage.

Repairs and maintenance must be authorized by Buffalo Turbine. Use spare parts from Buffalo Turbine only. Contact Buffalo Turbine at 716-592-2700 if you require service or other assistance. Keep the product in a dry, clean place. Keep contacts and antennas clean. Wipe off dust using a slightly damp, clean cloth. Never use cleaning solutions or high-pressure water.

Troubleshooting for Cyclone D1003 Remote / Receiver

Symptom – Does not throttle up properly.

1. Disconnect grey plug connected to the receiver. Grey plug must be removed by compressing the side tabs and pulling straight out as shown in Ref #1. Check to ensure that each wire is securely attached to the grey connector plug (see Ref #2). Ref # 2 shows a defective grey plug.
 - If wires will not pull out of the grey connector plug, reattach connector plug to the receiver and proceed to step 2.
 - If wire(s) pull out of connector plug, wire harness needs to be replaced. (see ref # 2)

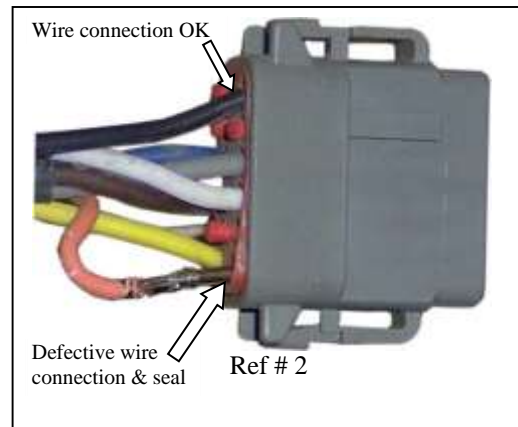

2. Check Remote Transmitter by pressing each button to ensure that the light on Transmitter has a green light.



- If the LED lights do not appear when pressing each button on the transmitter, verify switch on back of transmitter is turned on and/or replace transmitter batteries. If the LED lights still fail to function after replacing the batteries, replace the transmitter.
- If the lights functions correctly, proceed to step #3

3. With engine key switch in the run position (do not start the engine at this time), disconnect throttle wires (purple and green) between throttle actuator and wire harness at the quick disconnects. The following test will require an electronic multimeter, set to read at least 12 volts.

- Insert the red probe into the purple wire and black probe into the green wire. Press the throttle buttons up and down. (Voltage should read approx. +12 volts in one direction and approx. – 12 volts in the opposite direction.) If the proper voltage is confirmed and all wire connections are secure, the throttle actuator may need to be replaced, proceed to Step 4.

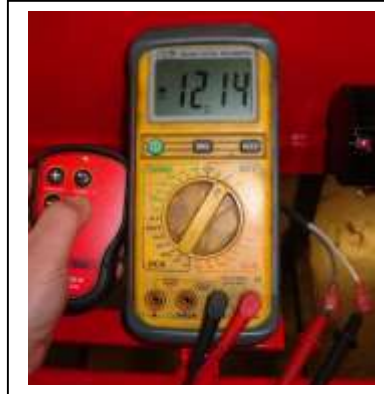

- If proper voltage has not been verified contact Buffalo Turbine for further instructions.

4. The engine should be off for the following tests. Apply power to the throttle actuator directly. Both wires from the throttle actuator need to be connected to the battery (see ref # 1). (ex. yellow wire to positive terminal and red wire to negative terminal) Then the wires need to be reversed on the battery (see ref # 2). (ex. yellow wire to negative terminal and red wire to negative terminal.)



(Ref # 1)



(Ref # 2)

- If the throttle actuator works properly, contact Buffalo Turbine for further instructions.
- If the throttle actuator will not move in one or both directions, the throttle actuator may need to be replaced.

If necessary, contact Buffalo Turbine at 716-592-2700 for more instructions.

Troubleshooting for D1003 Remote / Receiver Kit

Symptom: Nozzle will not rotate properly.

1. Disconnect grey plug connected to the receiver. Grey plug must be removed by compressing the side tabs and pulling straight out as shown in Ref #1. Check to ensure that each wire is securely attached to the grey connector plug (see Ref #2). Ref # 2 shows a defective grey plug.
 - If wires will not pull out of the grey connector plug, reattach connector plug to the receiver and proceed to step 2.
 - If wire(s) pull out of connector plug, wire harness needs to be replaced. (see ref # 2)

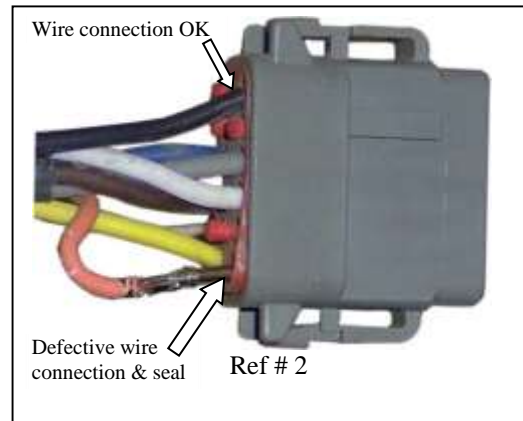

2. 2. Check Remote Transmitter by pressing each button to ensure that the light on Transmitter has a green light.



- If the LED lights do not appear when pressing each button on the transmitter, replace transmitter batteries. If a LED lights still fail to function after replacing the batteries, replace the transmitter.
 - If the lights functions correctly, proceed to step #3
3. Check the set screw on the rotation motor pulley to make sure pulley is not loose and spinning on the shaft.
 - If set screw is loose, rotate nozzle assembly until pulley and flat spot on shaft are aligned. Tighten set screw and test nozzle functions with remote.
 - If set screw is tight, proceed to step #4

4. With the engine key switch in the run position, disconnect the nozzle wires leading from the rotation motor and wire harness (white and grey) at the quick disconnects. The following test will require an electronic multi-meter, set to read at least 12 volts.

- Insert the red probe into the white wire and black probe into the grey wire. Press the nozzle buttons CW or CCW. (Voltage should read approx. +12 volts in one direction and approx. – 12 volts in the opposite direction.) If the proper voltage is confirmed and all wire connections are secure, proceed to step # 5



- If proper voltage has not been verified contact Buffalo Turbine for further instructions.

5. Apply power to the rotation motor directly. Both wires from rotation motor need to be connected to the battery. (Ex. white to positive terminal & black to negative terminal) Then reverse the wire connections to the battery. (Ex. black to positive terminal & white to negative terminal)

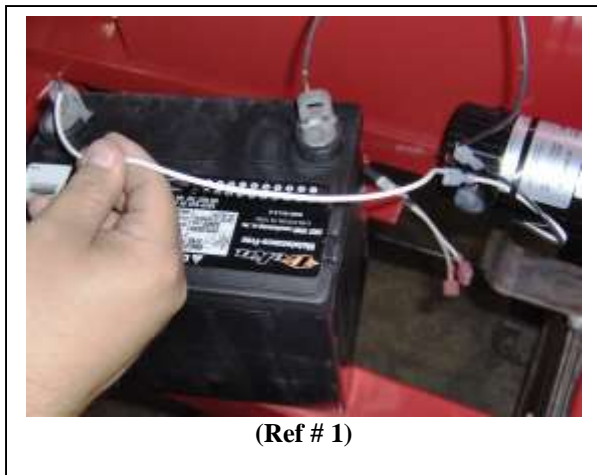

(Ref # 1)

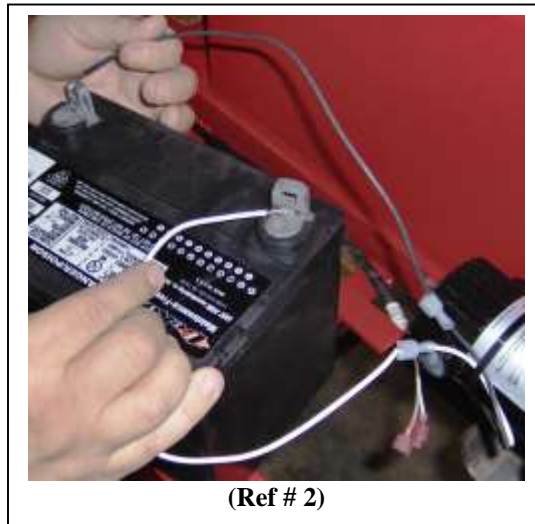

(Ref # 2)

- If rotation motor rotates in both directions, the motor is ok.
- If rotation motor will not rotate in either direction with power applied contact Buffalo Turbine.
- If rotation motor rotates in one direction but the other, contact Buffalo Turbine.

If necessary, contact Buffalo Turbine at 716-592-2700 for more instructions.



OPTIONS

 180 Zoar Valley Road
 Springville, NY 14141

NOZZLES +

Aerospace Polymer Nozzle - Part# 2851

Flexible Nozzle Assembly - Part# 3345
 Various lengths available. Ideal for rough terrain.

*Call sales and service to request custom nozzle configuration.

Gyratory Atomizing Nozzle - Part# 2547
 (Safety guard removed for clarity)

ALUMINUM NOZZLES

 Optional aluminum nozzles **will not** connect to the standard Aerospace Polymer Nozzle (Part# 2851). Requires: **Two 45° elbow segments (Part# 1171)** and two additional clamp bands (Part# 1173).

12" Extension - Part# 1468
20" Extension - Part# 1845
10" Round Nozzle - Part# 1417
12" Round Nozzle - Part# 1172
 Improves air velocity with lower horsepower and hydraulic blower units

10" Rectangular Nozzle - Part# 1469
19" Rectangular Nozzle - Part# 1425
 5.5"x15" opening - extra length/more concentrated air flow. Uses - heavy wet debris, plugs, top dressing. No ground clearance in the vertical down position.

Fishtail Nozzle - Part# 1743
 5"x30" (wide angle) opening. Distributes a large volume of air at a lower velocity over a wide area. Easily converts blower into a "Greens Fan". Adaptable to all models. Not as effective at moving debris.

D.O.T. TRAILER

Part# 1613-D for 8000, KB4, EFI & Mega



2" BALL RECEIVER HITCH

Part# 4605



FORK POCKETS

 Part# 4552
 Great for moving blowers around jobsites and bed mount / skid mount applications.

LINE DRIVER ATTACHMENT

Part# 2419



CORDED CONTROL

 Part# 5579 for KB7, MEGA 3 Model
 Part# 2787 for Diesel Model
 Part #5580 for Squared Model

CLAMP BAND W/ BOLT & NUT

Part# 1173



QUICK CONNECT CLAMP BAND

 Part# 4935
 Quickly remove or add nozzle with the barrel style clamp band.

WARNING:
 Cancer & Reproductive Harm -
 www.P65Warnings.ca.gov

BUFFALO TURBINE PRODUCTS

Cyclone eKB



Cyclone 8000 (& 8000 EFI)



Cyclone KB7



Cyclone MEGA



**The Original & Most Powerful
Turbine Debris
Blowers**
since 1945



BLITZ (& BLITZ MEGA)



Cyclone SQUARED



**Cyclone Hydraulic
(& Hydraulic MEGA)**



Cyclone PTO (& PTO MEGA)

Visit BuffaloTurbine.com for more product info