

# BUFFALO TURBINE

180 Zoar Valley Road  
Springville, NY 14141

TEL: 716 592 2700 FAX: 716 592 2460

EMAIL: [info@buffaloturbine.com](mailto:info@buffaloturbine.com)

[www.buffaloturbine.com](http://www.buffaloturbine.com)



**BT-MECV460T**

WITH TRAILER PACKAGE



**BT-MECV460S**

WITHOUT TRAILER PACKAGE (skid)

**BUFFALO TURBINE'S  
MONSOON ELECTRIC COMPLETE W/ VARIABLE FREQUENCY DRIVE  
OPERATOR'S MANUAL AND PARTS BOOK**

# BUFFALO TURBINE

## WARRANTY REGISTRATION FORM & INSPECTION REPORT

Any units not registered with Buffalo Turbine are not eligible for warranty claims

### WARRANTY REGISTRATION

**This form must be filled out by the dealer and signed by both the dealer and the customer at the time of delivery**

Customer's Name \_\_\_\_\_

Dealer's Name \_\_\_\_\_

Address \_\_\_\_\_

Address \_\_\_\_\_

City, State, Zip, Country \_\_\_\_\_

City, State, Zip, Country \_\_\_\_\_

Email Address (important) \_\_\_\_\_

Email Address \_\_\_\_\_

Telephone Number \_\_\_\_\_

Blower Model \_\_\_\_\_

**Circle one:**

Serial Number \_\_\_\_\_

Commercial Use

Delivery Date \_\_\_\_\_

Private Use

### DEALER INSPECTION REPORT

### SAFETY CHECKS

\_\_\_\_\_ Tire Pressure Check -- Model KB

\_\_\_\_\_ All Decals Installed

\_\_\_\_\_ Wheel Bolts

\_\_\_\_\_ Review Operating and Safety Instructions

\_\_\_\_\_ Belt Tension

\_\_\_\_\_ Lubricate Machine

\_\_\_\_\_ Guards in Place

\_\_\_\_\_ Fasteners Tight

\_\_\_\_\_ Trailer assembly bolts properly installed  
and tightened

I have thoroughly instructed the buyer on the above described equipment which reviews the included Operator's Manual content, equipment care, adjustments, safe operation and applicable warranty policy.

Date \_\_\_\_\_

Dealer's Rep. Signature \_\_\_\_\_

The above equipment and Operator's Manual has been received by me and I have been thoroughly instructed as to the care, adjustments, safe operation and applicable warranty policy.

Date \_\_\_\_\_

Owner's Signature \_\_\_\_\_

**PLEASE FAX A COPY TO BUFFALO TURBINE AT 716 592 2460 Or**  
**Email - [service@buffaloturbine.com](mailto:service@buffaloturbine.com)**

# SERIAL NUMBER LOCATION

Always give your dealer the serial number of your Debris Blower when ordering parts or requesting service or other information.

The serial number plate(s) is located where indicated in the pictures below. Please document the number in the space provided for easy reference.

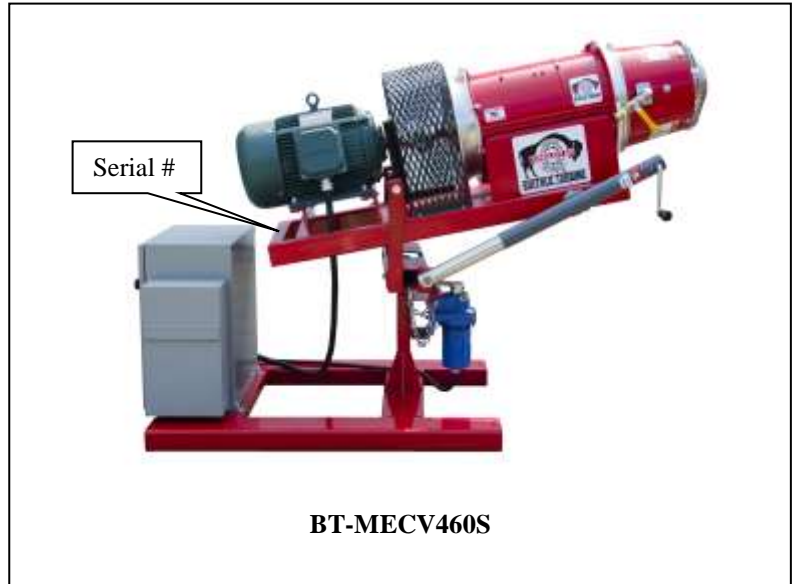

(The Electrical Panel Box designates the rear of the machine)

## MONSOON ELECTRIC COMPLETE W/ VARIABLE FREQUENCY DRIVE

Serial Number: \_\_\_\_\_

# **Buffalo Turbine Warranty Policy**

## **MACHINE WARRANTY INFORMATION**

Buffalo Turbine warrants the DEBRIS BLOWER, to the original owner, to be free from defects in material and workmanship, under normal use and service. **All machines must have a completed registration form sent to Buffalo Turbine within 30 days of purchase for warranty to apply.** Obligation under this warranty shall extend for a period of 10 years from date of purchase and, at the option of Buffalo Turbine, replacement of any parts found, upon inspection by Buffalo Turbine, to be defective. Any parts replaced under warranty will have the remainder of the warranty from the original date of purchase.

**Warranty parts during first 2 years will be shipped free of charge via standard ground shipping**

**\*If expedited shipping is required charges will be paid by the end user\***

Year 1: parts and labor

Year 2: parts only

**Customer will be required to pay shipping charges for years 3-10**

Year 3: Engine, per engine manufacturer's standard / Turbine Assembly / Frame (parts only)

Year 4-10: Turbine Assembly / Frame (parts will be prorated)

**Buffalo Turbine reserves the right to incorporate improvements in material and design of its products without notice and is not obligated to make the same improvements to equipment previously manufactured.**

**ALL WARRANTY REPAIRS NEED PRE-APPROVAL BY A FACTORY PERSON (FROM BUFFALO TURBINE) PRIOR TO COMMENCING WITH A WARRANTY REPAIR TO INCLUDE SERIAL NUMBER AND HOURS FROM HOUR METER (IF EQUIPPED). PRE-APPROVAL WILL BE REQUIRED BY THE END USER AND DEALER/DISTRIBUTOR LEVEL.**

**Factory ordered Buffalo Turbine parts must be used when filing a warranty claim.**

### **LIMITATIONS OF LIABILITY**

This warranty is expressly in lieu of all other warranties expressed or implied and all other obligations or liabilities on our part of any kind or character, including liabilities for alleged representations or negligence. We neither assume nor authorize any other person to assume on our behalf, any liability in connection with the subsequent sale of the **DEBRIS BLOWER**. This warranty shall not apply to any DEBRIS BLOWER, which has been altered outside the factory in any way so as, in the judgment of Buffalo Turbine, to affect its operation or reliability, or which has been subject to misuse, neglect, or accident.

This warranty does not cover parts and accessories, which are under separate guarantee from the manufacturers and service can be, obtained from their service facilities. No warranty is extended to regular service items such as lubricants, belts, paint and the like.

### **Original Instruction Manual**

The Purchaser acknowledges having receiving training in the safe operation of the DEBRIS BLOWER and further acknowledges that Buffalo Turbine does not assume any liability resulting from the operation of the DEBRIS BLOWER in any manner other than described in the Operator's Manual supplied at the time of purchase.

**WARRANTY VOID IF NOT REGISTERED (see Page 2 for warranty registration form)**

**DO NOT SPLIT THE TURBINE HOUSING FOR ANY REASON.**

**DO NOT ATTEMPT TO SERVICE OR DISASSEMBLE THE TURBINE BLOWER.**

**DO NOT USE THE TOP OF THE TURBINE HOUSING TO STRAP OR TIE DOWN BLOWER UNITS.**

**Unauthorized service work on the Turbine Blower will null and void all warranties.**

If there are any questions regarding any of our products call Buffalo Turbine at 716 592 2700.

## 1. INTRODUCTION

Congratulations on your choice of the Buffalo Turbine Monsoon Electric Dust Suppression unit. This equipment has been designed and manufactured to meet the needs of the construction/demolition industry.

Safe, efficient and trouble-free operation of your Buffalo Turbine Blower requires that you and anyone else, who will be operating or maintaining the Blower, read and understand all of the safety, operation, maintenance and trouble shooting information contained within this Operator's manual.

This Manual covers the Monsoon BT-MECV style units.

Keep this manual handy for frequent reference and to pass on to new operators or owners. Call your Buffalo Turbine dealer or distributor if you need assistance, information, or additional copies of the manuals.



**OPERATOR ORIENTATION** – The directions left, right, front and rear, as mentioned throughout the manual, are as seen from the electrical box (rear) and facing in the direction of nozzle.

## 2. SAFETY

### SAFETY ALERT SYMBOL

This Safety Alert symbol means **ATTENTION! BECOME ALERT! YOUR SAFETY IS INVOLVED!**

The Safety Alert symbol identifies important safety messages on the Buffalo Turbine Blower and in the manual. When you see this symbol, be alert to the possibility of personal injury or death. Follow the instructions in the safety message.

Why is **SAFETY** important to you?



**3 Big Reasons: Accidents Disable and Kill  
Accidents Cost  
Accidents Can Be Avoided**

**SIGNAL WORDS:** Note the use of the signal words **DANGER**, **WARNING** and **CAUTION** with the safety messages. The appropriate signal word for each message has been selected using the following guidelines:

1. **DANGER** – An immediate and specific hazard that **WILL** result in severe personal injury or death if the proper precautions are not taken.
2. **WARNING** -- A specific hazard or unsafe practice that **COULD** result in severe personal injury or death if proper precautions are not taken.
3. **CAUTION** – Unsafe practices that **COULD** result in personal injury if proper practices are not taken, or as a reminder of good safety.

## 2.1 SAFETY

**YOU** are responsible for the **SAFE** operation and maintenance of your Buffalo Turbine unit. **YOU** must ensure that you and anyone else, who is going to operate, maintain or work around the Buffalo Turbine unit be familiar with the operating and maintenance procedures and related **SAFETY** information contained in this manual. This manual will take you step-by-step through your working day and alerts you to all good safety practice while operating this piece of equipment.

Remember **YOU** are the key to safety. Good safety practices not only protect you but also the people around you. Make these practices a working part of your safety program. Be certain that **EVERYONE** operating this machine is familiar with the procedures recommended and follows safety precautions. Remember most accidents can be prevented. Do not risk injury or death by ignoring good safety practices.

- Monsoon owners must give operating instructions to operators or employees before allowing them to operate this piece of equipment, and at least annually thereafter.
- The most important safety device on this equipment is a **SAFE** operator. It is the operator's responsibility to read and understand ALL Safety and Operating instructions in the manual and to follow these. All accidents can be avoided.
- A person who has not read and understood all operating instructions is not qualified to operate the machine. An untrained operator exposes themselves and bystanders to possible serious injury or death.
- Do not modify the equipment in any way. Unauthorized modification may impair the function and/or safety which could affect the life of the equipment.
- Think **SAFETY!** Work **SAFELY!**

## 2.2 GENERAL SAFETY

1. Read and understand the Operator's Manual and all safety signs before operating, maintaining, and adjusting.
2. Provide a first-aid kit for use in case of an accident. Store in a highly visible place.
3. Provide a fire extinguisher for use in case of an accident. Store in a highly visible place.
4. Wear appropriate protective gear. This list includes but is not limited to:
  - A hard hat
  - Protective shoes with slip resistant soles
  - Protective glasses or goggles
  - Heavy gloves
  - Wet weather gear
  - Hearing protection
5. Do not operate without guards or shields properly installed.
6. Do not allow riders.
7. **Wear appropriate ear protection for prolonged exposure to excessive noise.**
8. **(All Models) Set Unit on level ground, stop motor, wait for all moving parts to stop before servicing then disconnect main power source.**
9. Clear the area of people, especially small children, before starting the unit.
10. Review all safety related items annually with all personnel who will be operating or maintaining the Monsoon unit.
11. Keep hands, feet, hair and clothing away from moving parts.
12. Operate equipment in a safe, secured or designated area.

## 2.3 OPERATING SAFETY

1. Read and understand the Operator's Manual and all safety signs before operating, servicing or adjusting.

## **2.4 MAINTENANCE SAFETY**

1. Read and follow ALL general, operating, maintenance and safety information in this manual.
2. Make sure all guards are in place and properly secured when operating or maintaining the Blower.

## **2.5 TRANSPORT SAFETY**

1. **ALL MONSOON UNITS MUST BE SECURELY ANCHORED TO THE VEHICLE BEING USED BEFORE TRANSPORTING.**

## **2.6 STORAGE SAFETY**

1. Store the Monsoon on a firm, level surface.
2. Store away from areas of human activity. Do not permit children to play on or around the stored machine.
3. Make sure the unit is sitting, or blocked up firm and solid and will not tip or sink into a soft area.
4. Cover with a weatherproof tarpaulin and tie down securely.

## **2.7 TIRE SAFETY**

1. Do not attempt to mount a tire unless you have the proper equipment and experience to do the job.
2. Have a qualified tire dealer or repair service perform required tire maintenance.

## **2.8 SAFETY DECALS**

Keep safety decals and signs clean and legible at all times.

1. Replace safety decals and signs that are missing or have become illegible.
2. Replaced parts that displayed a safety sign should also display the current sign.
3. Safety decals or signs are available from your Dealer Parts Department.





### 3. SAFETY DECALS

The types of decals on the blower unit are shown below. For locations of each label, see parts reference in the back of this manual.

Good safety requires that you familiarize yourself with the various Safety Decals, the type of warning and the area, or particular function related to that area that requires your **SAFETY AWARENESS**.

**\* THINK SAFETY! WORK SAFELY!**

#### ATTENTION!

1. **KEEP HANDS, FEET AND CLOTHING AWAY FROM POWER DRIVEN PARTS.**
2. **STOP ENGINE AND REMOVE KEY BEFORE LEAVING OPERATOR'S POSITION.**
3. **MACHINE MUST COME TO A COMPLETE STOP BEFORE ANY MAINTENANCE, TO INCLUDE ADJUSTING, LUBRICATING OR CLEANING, IS PERFORMED.**
4. **KEEP PEOPLE AND PETS AT SAFE DISTANCE FROM MACHINE.**
5. **KEEP ALL GUARDS AND SHIELDS IN PLACE.**

Part # 1185  
Turbine Decal



Part # 1233  
Turbine Decal



Part # 1227  
Turbine Decal



Part # 1184  
Turbine Decal



Part # 1186  
Turbine Decal



**REMEMBER – If safety decals have been damaged, removed, become illegible or parts replaced without decals, new decals must be applied. New decals are available from your authorized dealer.**

## 4.0 OPERATIONS

### 4.1 TO THE NEW OPERATOR OR OWNER

Buffalo Turbine Monsoon are designed to spray a fine mist of water particles to control dust. The material is conveyed on a stream of high volume and velocity of air and water to remove it from the area of concern.

Many of the features incorporated into the machine are the result of suggestions made by customers like you. Read the manual carefully to learn to operate the machine safely and how to set it to provide maximum efficiency. The manual will take you step-by-step through your working day. By following the operating instructions in conjunction with a good maintenance program, your Monsoon will provide many years of trouble-free service.

#### **Potential Mechanical Hazards while operating your machine:**

Never operate the monsoon or tractor around others to prevent the possibility of being run over by equipment.  
Never ride on your monsoon or tractor to prevent the possibility of being thrown off the machine or hurt severely.

#### **Potential Crushing Hazards while operating your machine:**

Between tractor arms and blower frame arms  
Between tractor deck and blower guard shroud  
Between tractor deck and tractor arms  
Between Pin at the end of the mounting arms



**WARNING:**  
This Product can expose you to chemicals which are known to the State of California to cause cancer and birth defects or other reproductive harm.  
For more information go to [www.P65Warnings.ca.gov](http://www.P65Warnings.ca.gov).

### 4.2 BREAK-IN

Although there are no operational restrictions on the Monsoon when it is used for the first time, it is recommended that the following mechanical items be checked:

#### **A. Operating for first ½ hour**

1. Re-torque all other fasteners and hardware.
2. Check set screw (nozzle pulley) to ensure it tightened.

#### **B. Operating for first 5 hours**

1. Re-torque all hardware and fasteners.
2. Check set screw (nozzle pulley) to ensure it tightened.
3. Go to the normal servicing and maintenance schedule as defined in the Maintenance Section of the manual.

### 4.3 PRE-OPERATION CHECKS

Efficient and safe operation of the Buffalo Turbine Blower requires that each operator reads and understands the operating procedures and all related safety precautions outlined in this section. A pre-operation checklist is provided for the operator. It is important for both personal safety and maintaining the good mechanical condition of the machine that this checklist is followed.

Before Operating the Blower and each time thereafter, the following areas should be checked off.

1. Make sure all guards and shields are in place, secured and functioning as designed.
2. Lubricate machine per maintenance schedule.
3. Ensure that the machine is properly attached to the (appropriate) power unit attaching arms and that the mounting pins are secured in position.
4. Ensure the PTO driveline is securely attached and can telescope easily.
5. Check that all clamp bands are secure.
6. Check the belts and pulleys for proper tension and alignment.

#### 4.4 Storage

At the end of the working season or before storing the Monsoon unit, prepare the machine by following this procedure:

1. Select a storage area that is dry, level and free of debris.
2. Thoroughly wash the machine daily with a water hose to remove all debris and residue.
3. Run the machine at low RPM to dry the Blower Components.
4. Touch up all paint chips and scratches to prevent rusting.
5. Inspect for worn or failed components. Order the replacement parts and repair the Monsoon unit when time allows. This will eliminate unnecessary down time.
6. Store in an enclosed building. If space is not available, cover with a waterproof tarpaulin and tie it down securely.
7. Store the machine away from areas of human activity.
8. Do not allow children to play around the stored unit.

### **SERVICE**

#### 4.5 FLUIDS & MAINTENANCE

Lubricate electric motor per Manufacturer's specification (see electric motor owner's manual section).

A Teflon spray type lubricant on the nozzle base and slides provides for freer rotation.

#### 4.6 SERVICE CHECKLIST

See Lubrication and Maintenance sections for details of service. Copy this page to continue record.

#### **TURN OFF TRACTOR, REMOVE KEY & DISCONNECT WIRE HARNESS BEFORE SERVICING BLOWER UNIT**

CODE: LUBRICATE-(L) / CHECK-(\* ) / CHANGE-(C) / REPLACE-(B) / CLEAN-(CL)

**SCHEDULED MAINTENANCE HOURS** \_\_\_\_\_

**SERVICED BY** \_\_\_\_\_

#### **MAINTENANCE**

##### **8 hrs or daily**

(\* ) Remove all debris that has settled between the blower wheel fan and the stationary vanes.

Helps maintain peak performance.

(\* ) Check Clamp Band Bolt for tightness

##### **40 hours or weekly**

(\* ) Check condition of belts

(L) Nozzle base slides (Teflon or Silicone spray)

(\* ) Check set screw (nozzle pulley) to ensure it is tightened

(\* ) Wash and Clean any dirt or grime build up that has accumulated on blower wheel fan blades. Helps to minimize vibration balance and maintain peak performance.

(\* ) Check condition of coupling (center section # 1256) connecting bolts and nuts during each oil change or when experiencing vibration or unusual noises

##### **200hrs or annually**

(CL) Machine

**DO NOT OPERATE BLOWER UNIT WITHOUT GUARDS SECURELY ATTACHED**

## 5.0 TROUBLE SHOOTING

If you encounter a problem that is difficult to solve, even after reading through this trouble shooting section, please call your local dealer or distributor. **Before calling, please have this Operator’s Manual and the serial number from your Monsoon unit ready.**

In the following section, we have listed causes and solutions to the problems that you may have encountered.

**TURN OFF MOTOR AND DISCONNECT FROM POWER SOURCE BEFORE SERVICING MONSOON UNIT. INSTALL GUARDS BEFORE OPERATING.**

<b>PROBLEM</b>	<b>CAUSE</b>	<b>SOLUTION</b>
No air flow	Build up of debris inside turbine	Remove nozzle and clean debris from inside turbine
	Broken coupling	Replace coupling
No air flow	Blower fan not turning	See solutions above
Reduced or no air flow	Blower fan turns	Air intake restricted on guard and in blower assembly Shut off motor – remove restrictions Debris cannot be allowed to build up between the blower fan and stationary vanes
Machine vibrates or Unusual sounds	Bearing or coupling failure Out-of-balance	Replace bearings or coupling Have your dealer check blower for damaged blades. Wash and clean blower fan blades

## 6. SPECIFICATION

<b>Length:</b>	<b>BT-MECV460T</b> 98” With tow bar handle 84” without tow bar handle	<b>BT-MECV460S</b> 71”
<b>Width:</b>	55”	38.5”
<b>Height:</b>		51”
<b>Weight:</b>		940 lbs. (427 kg)
<b>Tires:</b>	Turf 18.5 x8.50-8	NA
<b>Electrical System:</b>	460 ACV 60HZ	460 ACV 60HZ
<b>Input Power:</b>	20 hp Leeson Electric Motor	20 hp Leeson Electric Motor
<b>Output RPM:</b>	Up to 3500 RPM	Up to 3500 RPM
<b>Outlet Size:</b>	Approximately 12”	Approximately 12”

# INSTALLATION INSTRUCTIONS & PARTS FOR THE MOREFLEX COUPLING

## ALIGNMENT OF TURBINE SHAFT WITH SHAFT OF MOTOR IS CRITICAL

1. Install keys in both shafts.
2. Slide coupling flanges on both shafts (engine and turbine shafts)
3. Place Moreflex coupling CENTER SECTION between coupling flanges and secure with 4 bolts and TOPLOC nuts. The bolt heads are positioned against the coupling in alternating directions. Tighten all 4 bolts. DO NOT TIGHTEN SET SCREWS AT THIS TIME.
4. Check key for proper position under the set screw hole on both shafts.
5. Place several drops of Loctite 271 into these two holes only. Set screws and tapped screw holes must be free of dirt and oil for Loctite to work properly.
6. Install the set screws over the keys and tighten firmly.
7. Using a drill point, dimple each shaft through the other 2 set screw holes. Clean drill chips, oil and dirt before applying Loctite.
8. Place several drops of Loctite 271 in these 2 holes.
9. Install and tighten set screws in these 2 holes.
10. Check and retighten the 4 bolts that hold the coupling center section in place.
11. Visually inspect the unit and replace the guard. DO NOT OPERATE WITHOUT THE GUARDS IN PLACE.

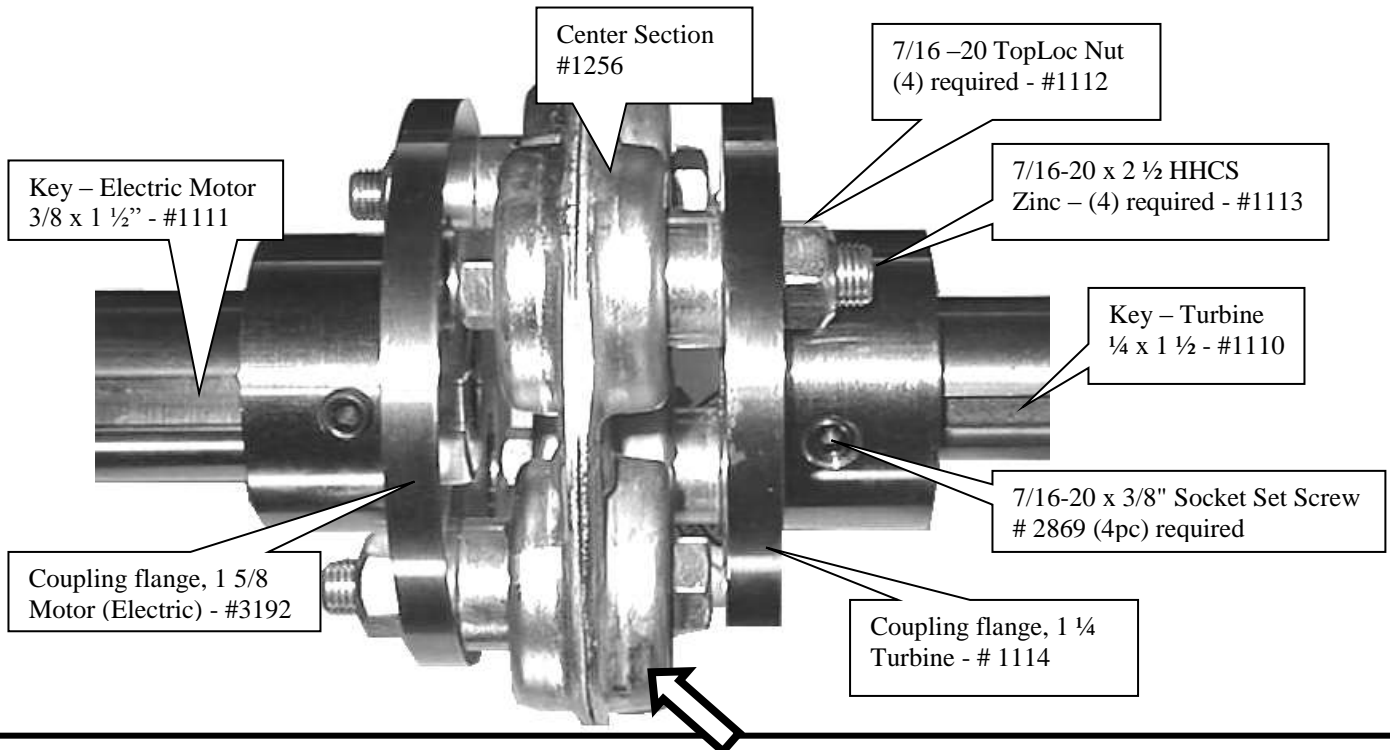

Part # 1256 (center section) is a **“WEAR”** item that should be visually checked each time the engine oil is changed. This coupling is equipped with special lock nuts. Occasionally check that all 4 nuts are securely fastened. **LOOK FOR CRACKS IN THE RUBBER COMPOSITION THAT SURROUNDS THE 4 BUSHINGS. Replace the center section when the rubber composition begins to show ANY signs of cracking OR an increase in vibration OR unusual sounds. When in doubt, call our Service Department.**

## **MOUNTING BLOWER ASSEMBLY ONTO FRAME** **AND ALIGNMENT RECOMMENDATIONS**

1. Install blower assembly onto frame and tighten all of the bolts.
2. Remove all burrs and oil from the shafts and keyways (engine and blower shafts).
3. Using the supplied gauge, align the shafts parallel to each other (very important).
4. Check in four places around the shafts at 90° to each other.
5. When properly aligned, gauge should have little to no gap between itself and the shafts at any point along the gauge.
6. To adjust, move the engine. The 2 mounting brackets have tapped holes in each corner to help support and adjust the position of the engine. The 4 roll pins may need to be repositioned after alignment is completed and bolts are tightened.
7. Tighten all engine bolts and recheck alignment. Drill and install 4 roll pins in new position.

### **ACCEPTABLE**

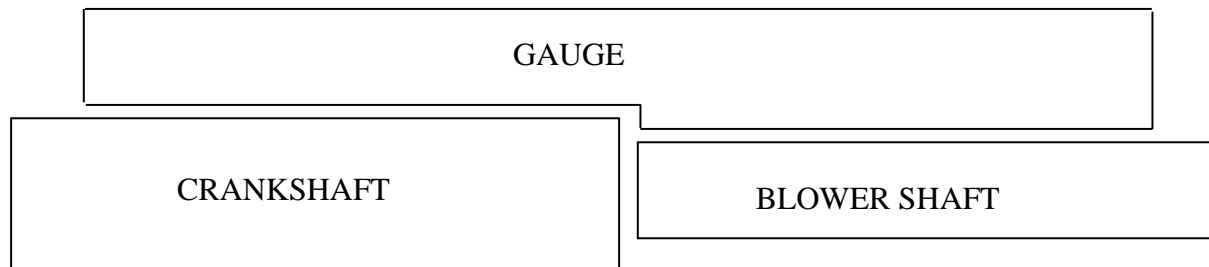

### **NOT ACCEPTABLE**

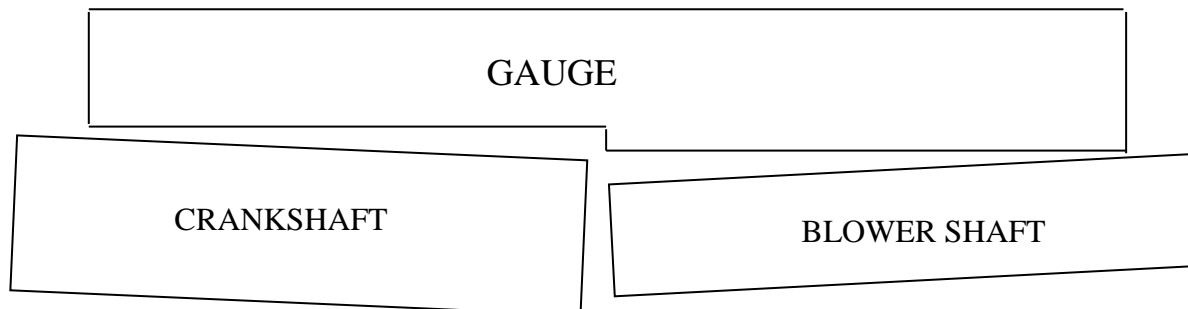

SECURELY ATTACH GUARDS BEFORE OPERATING BLOWER UNITS

# BT-MECV460T

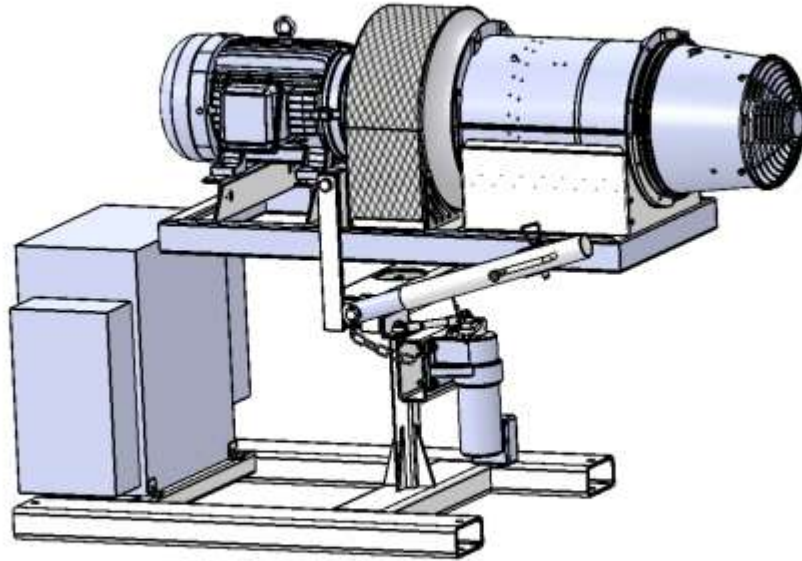

## BT-EL12M-460

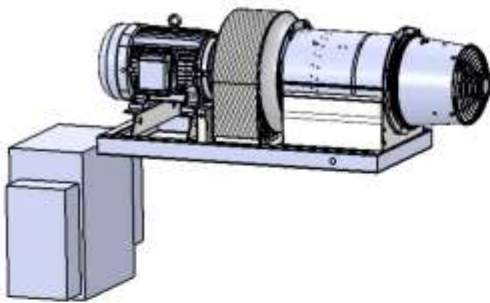

## BT-OS-VFD-22

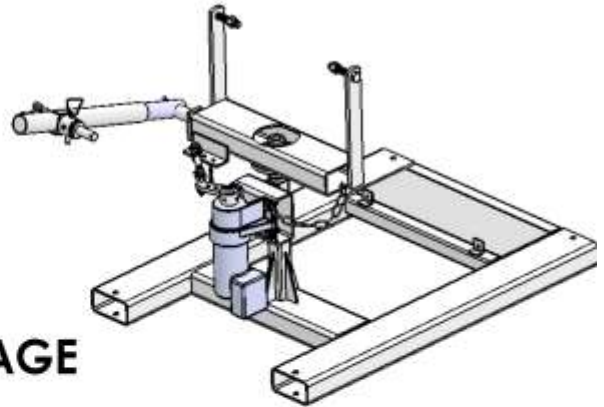

## 2695 - TRAILER PACKAGE

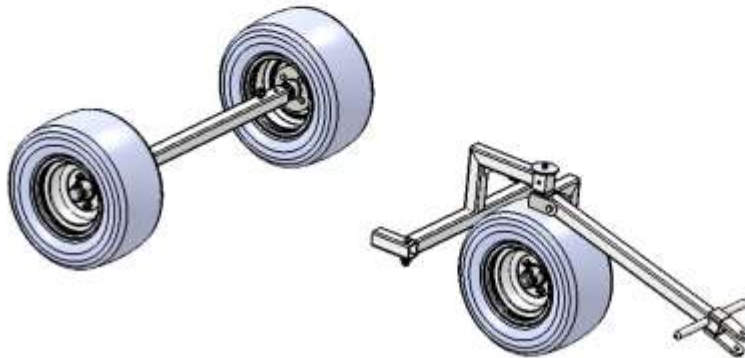

# BT-MECV460S

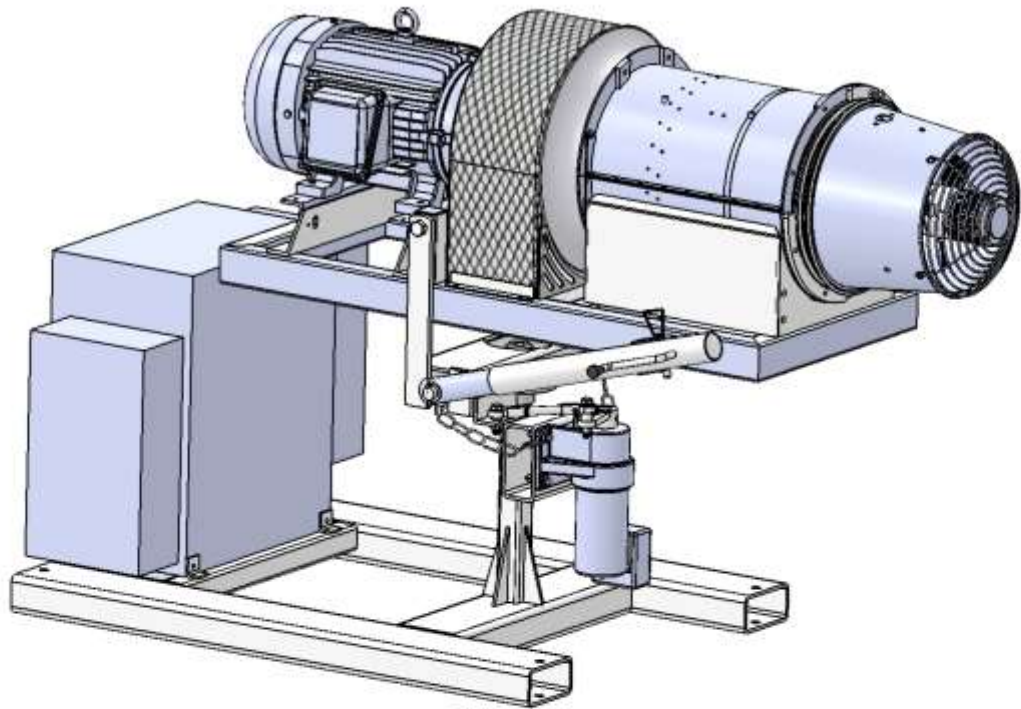

## BT-EL12M-460

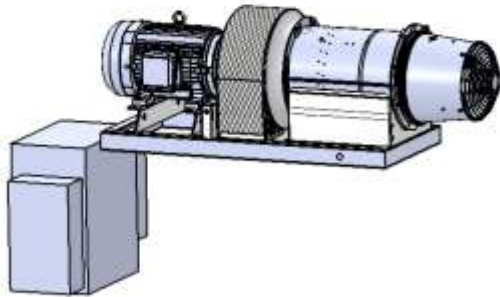

## BT-OS-VFD-22

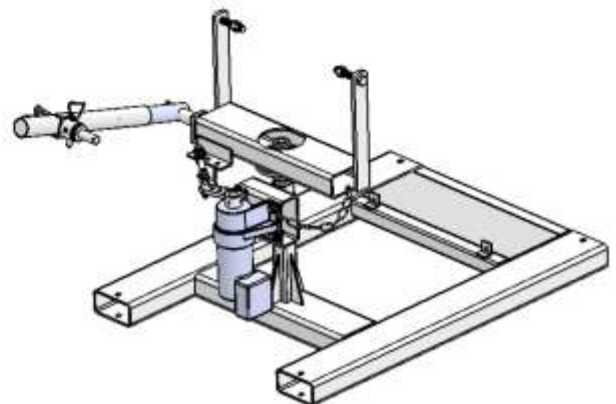



## BT-EL12M-460 PARTS REFERENCE

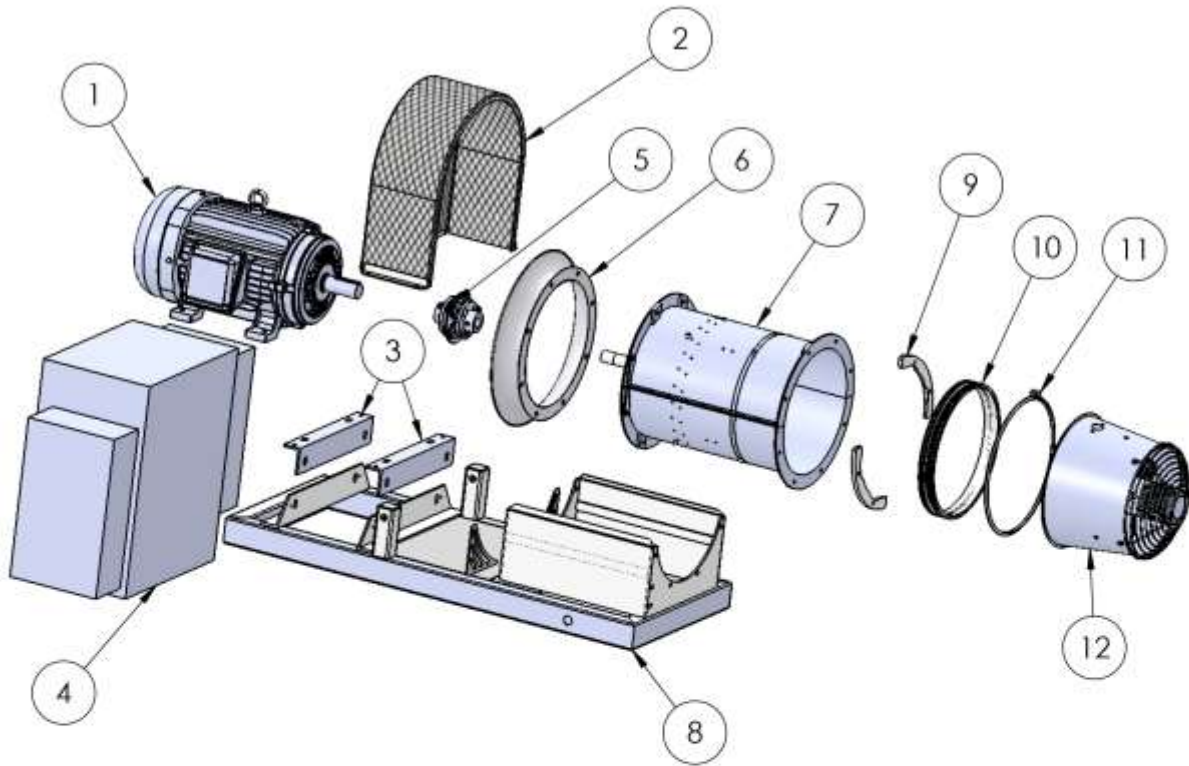

## BT-EL12M PARTS LIST

ITEM	QTY	DESCRIPTION	PART #
1	1	LESSON 20HP 460V ELECTRIC MOTOR	3190
2	1	GUARD	3219
3	2	MOTOR FRAME RAILS	3187
4	1	VFD (VARIABLE FREQ DRIVE) BOX	3191
5	1	MORFLEX COUPLING ASSEMBLY	SEE PAGE
6	1	BELLMOUTH	1119
7	1	BLOWER ASSEMBLY	1164
8	1	FRAME, BT-EL12	3184
9	2	SLIDES, NYLON	1138
10	1	ELBOW BASE RING	1141
11	1	CLAMP BAND W/ NUT AND BOLT	1173
12	1	MONSOON NOZZLE	2547

## BT-OS-VFD-22 PARTS REFERENCE

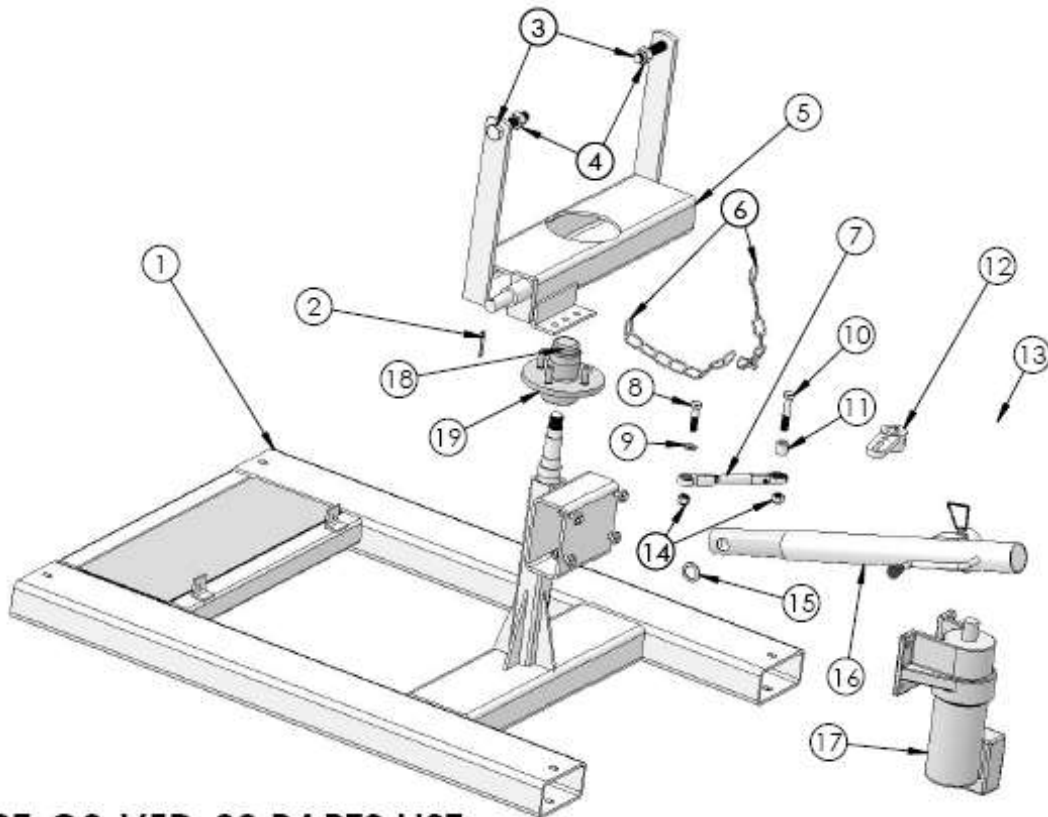

### BT-OS-VFD-22 PARTS LIST

ITEM	QTY.	DESCRIPTION	PART #
1	1	OSCILLATION BASE	3185
2	1	1/8 X 1-1/2" COTTER PIN	1152
3	2	3/4-10 X 4" HHCS	2667
4	2	3/4-10 NYLOC NUT	2668
5	1	OSCILLATING BASE UPPER WELDMENT	2658
6	2	SAFETY CHAIN ASSEMBLY	2791
7	1	ROD END LINKAGE ASSEMBLY	2834
8	1	1/2-13 X 2" HHCS	2832
9	1	3/16" X 7/8" OD WASHER	2819
10	1	1/2-13 X 2-3/4" HHCS	2835
11	1	13/16" X 7/8" OD WASHER	2820
12	1	CRANK ARM	2804
13	1	TUBE JACK MOUNTING PIN WELDMENT	2707
14	2	1/2-13 NYLOC NUT	1180
15	1	1" WASHER	2683
16	1	TUBE JACK	2681
17	1	OSCILLATION MOTOR, W/LINE SPEED REDUCER	2669
18	1	BBEARING CAP FOR HUB	1575
19	1	5 BOLT 4-1/2" HUB	TT-512

## 2695 - TRAILER PACKAGE PARTS REFERENCE

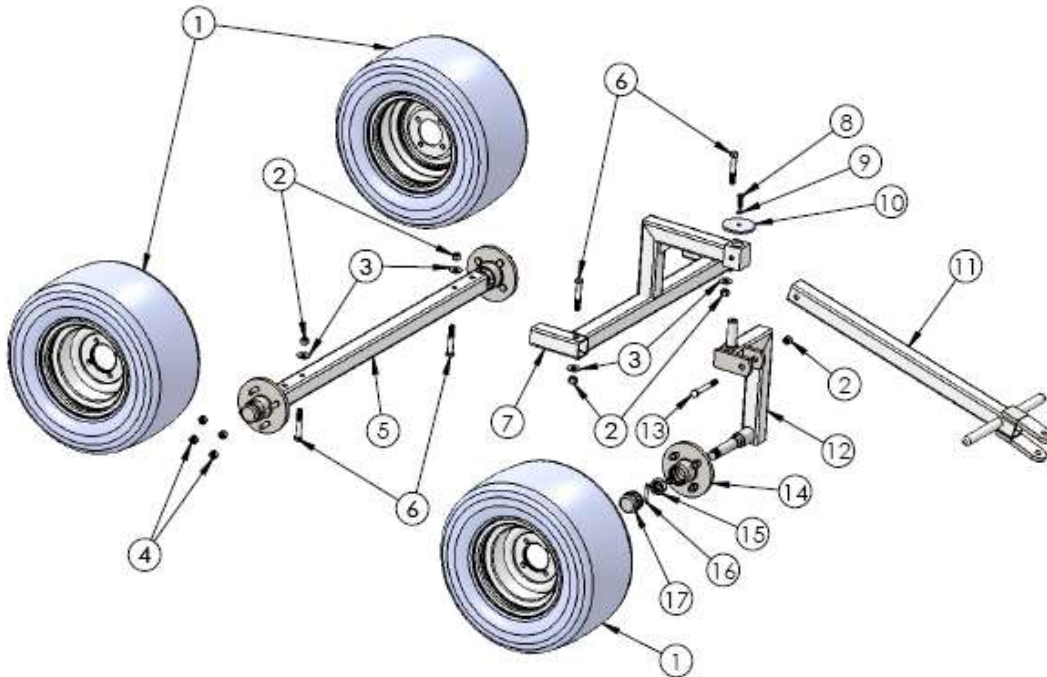

### TRAILER PACKAGE PARTS LIST

ITEM	QTY.	DISCRIPTION	PART #
1	3	WHEEL AND TIRE	2019
2	5	1/2-13 NYLOC NUTS	1180
3	4	1/2 FLAT WASHER	1226
4	12	1/2-20 LUG NUT	1576
5	1	AXLE WELDMENT	2831
6	4	1/2-13 X 3-1/4 HHCS	1137
7	1	TRAILER BRACKET	2714
8	1	3/8-24 X 1-1/4 HHCS	1100
9	1	3/8 LOCK WASHER	1107
10	1	3-1/2" OD WASHER	2871
11	1	TOW BAR / HANDLE	2712
12	1	WHEEL BRACKET	2713
13	1	1/2-13 X 4 HHCS	1444
14	1	HUB WITH STUDS	1153
15	1	1"-14 CASTLE NUT	1151
16	1	1/8 X 1-1/2" COTTER PIN	1152
17	1	BEARING CAP FOR HUB	1575

## Oscillation Table Trailer Package Assembly

The Oscillation Stand Trailer package consists of two bolt on weldments  
The trailer package easily attaches to the Oscillation Table using the four bolts supplied.

1. Safely lift and support the unit with the proper equipment for assembly and disassembly.

**\*\*\* Note:** It is recommended to use anti-seize on axle weldments bolts for ease with future disassembly

2. The Rear Axle Weldment consists of a tubular axle, and 2 wheels. The rear weldment can easily be rolled into place and bolts to the stand with two bolts placed from the bottom upward. (Figure 1)

**Note:** Once the rear Weldment is bolted in place use proper size chocking blocks to ensure safety by keep equipment from rolling or pivoting during final assembly.

3. The Front Axle Weldment consists of one wheel and tire that swivels freely 180° with a combination tongue and handle that bolts on the stand with two bolts. These bolt down through from the top. (Figure 2)

4. The tongue bolts to front wheel spindle as shown. (Figure 2 b)
5. Put on the wheels and tighten all wheel lug nuts.

**\*\*\*Oscillation table should not be moved with forklift once trailer package is bolted on.\*\*\***

### Rear Axle Mounted to Oscillation Table

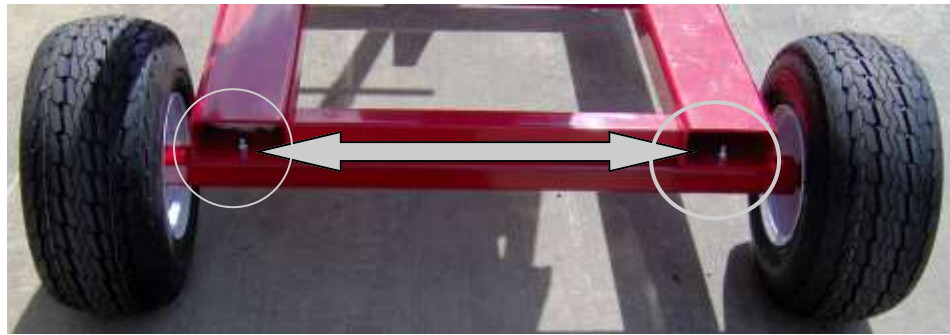

### Front Axle Mounted to Oscillation Table

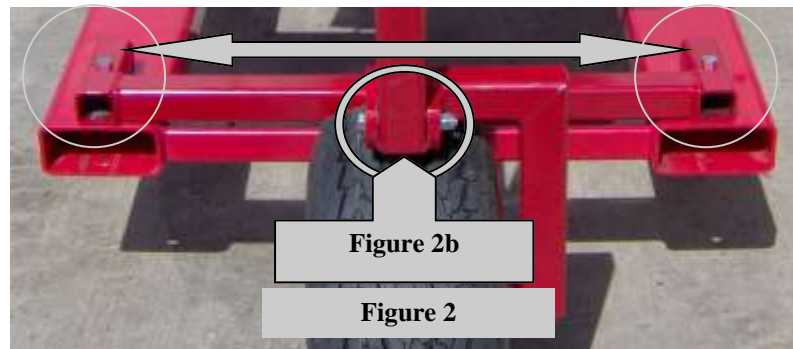

# Oscillation Stand Trailer Package

**Warning:  
Chocking Blocks  
Must be Used!**



## **Chocking and Blocking Safety**

When using the Oscillation Table Trailer Package: Chocking and blocking must be used to prevent accidental or unintended movement of the trailer equipment and cargo while workers are loading, unloading, hitching, unhitching, or performing service or maintenance.

When chocking, use specially designed wheel chocks of the appropriate size and material to securely hold the trailer. Do not use lumber, cinder blocks, rocks, or other make-shift items to chock.



Chocking Blocks  
Should always  
be used



## Oscillation Table Assembly

### **Attaching Electric Monsoon to Oscillation Table**

1. The Monsoon unit should be held in place with some sort of lifting equipment, to make attaching oscillation table safe and easy.

2. Gently set Monsoon unit down into upper weldment, Then align the bolt holes there is one hole each side.

3. Insert the two 3/4 - 10 X 4" bolts, thru the two vertical upright brackets both sides and tighten. Do not over tighten. (Ref 17)

4. Attach the tube jack and handle assembly to oscillation stand first, unit using the supplied washers and cotter pins. (Ref 20 & 21)

5. Attach tube jack to the Monsoon unit using the pivot stub again using the supplied washers and cotter pins, then align holes in pivot stub with tube jack and Insert safety pin.

(Ref 10)

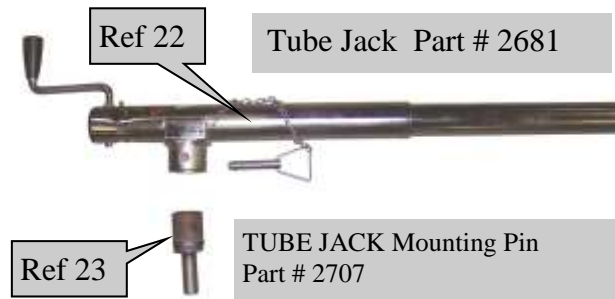
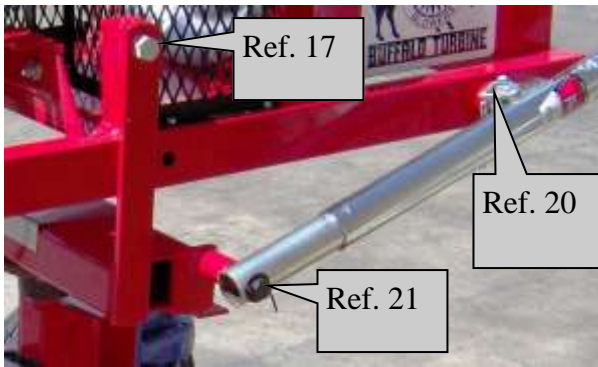

## Oscillation Table (Crank Arm Assembly) Parts and Locations

Ref #	Part #	Description	Qty.
27	1180	Nyloc Nut, 1/2-13	2
28	2835	1/2-13 x 2-3/4" long HHCS	1
29	2820	13/16" x 7/8" OD Washer	1
30	2819	3/16" x 7/8" OD Washer	1
31	2832	1/2-13 x 2" HHCS	1
32	2834	ROD END LINKAGE ASSEMBLY CONSISTS OF (2)1237, (1)2805, (2)2833 all Red LOCTITED TOGETHER	1
33	2804	Crank Arm, Steel	1

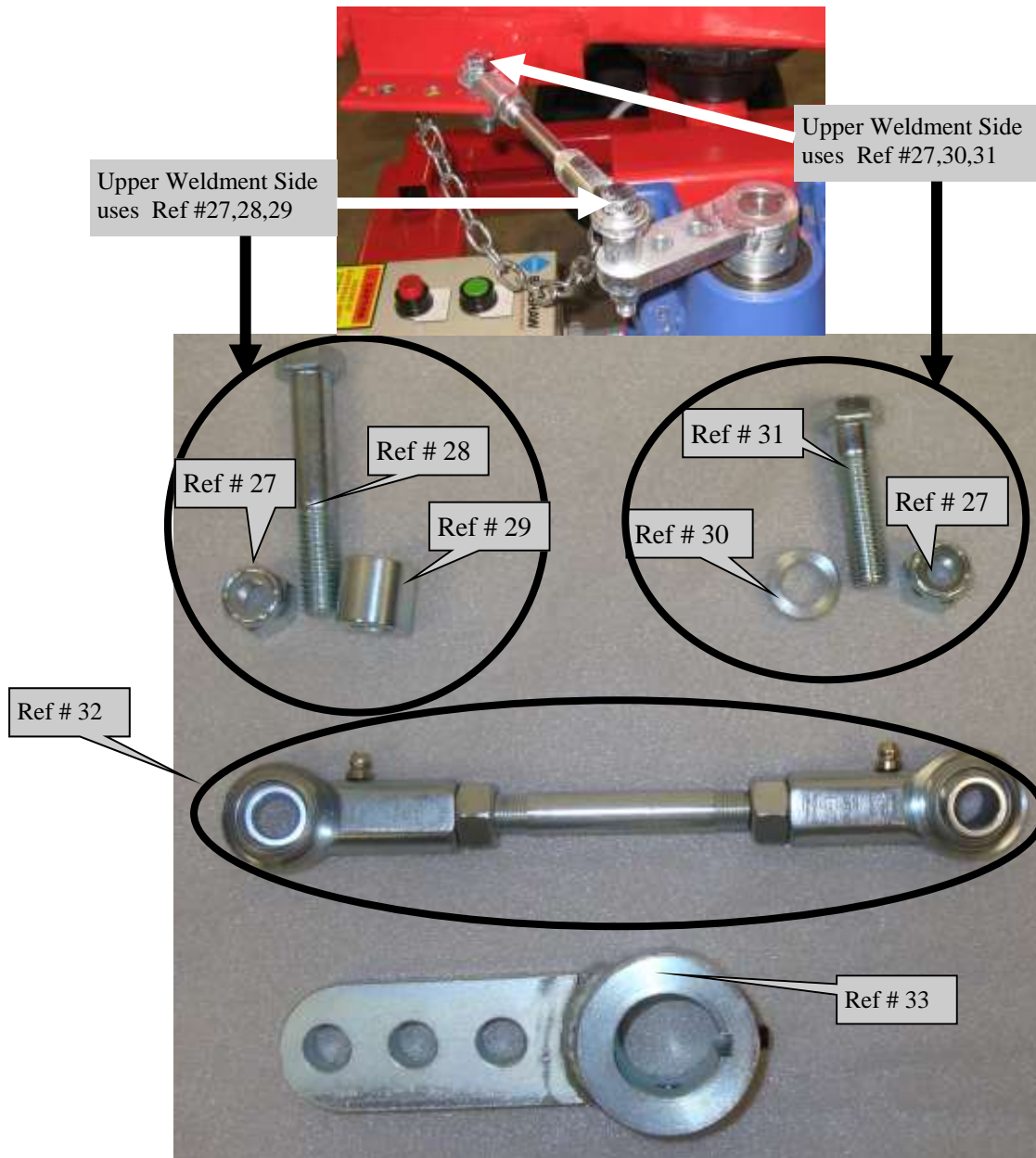

## Gyratory Atomizing Nozzle (Part # 2547) Parts and Locations

Ref #	Part #	Description	Qty.
1	2665	Monsoon Nozzle	1
2	2605	Nozzle Cage	1
3	2574	Cage End Cap, Monsoon	1
4	2663	Cage End Cap Bolts (Torque to 31 " lbs)	3
5	2664	10-32 Stainless Steel Split Lock Washer	3
6	2592	3/8 x 5.7" Long Support Rod, Monsoon	3
7	1105	3/8 - 24 Hex Nut, Zinc Plated Grade 5 (Inside Jam Nuts)	6
8	1108	3/8 Flat Washer Zinc Plated , Support Rods	6
9	1935	3/8 - 24 Nyloc Nut, Support Rods (Outside)	3
10	2675	3/4 Street "L" 304 Stainless 150 lb	2
11	1525	Ball Valve	1
12	2678	Rubber Retaining Gasket, Monsoon	1
13	2679	Gasket Retainer Stainless, Monsoon	1
14	2711	Screen, Stainless Monsoon	1
N/A	2677	Brass Garden Hose Adapter and Washer Photo N/A at time of printing	1
N/A	2881	Gyratory Atomizing Nozzle Guard (guard has been removed for clarity)	1

**PLEASE CONTACT BUFFALO TURBINE AT 716-592-2700**

**BEFORE ATTEMPTING TO SERVICE GYRATORY ATOMIZING NOZZLE.**

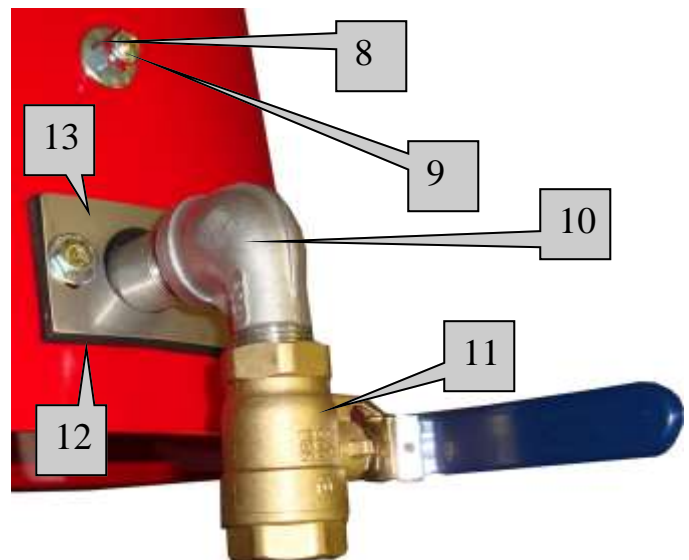
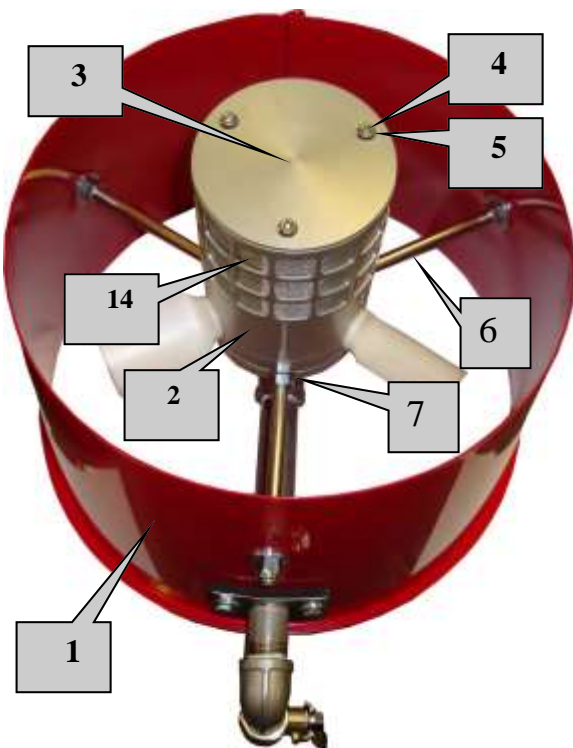



# OPTIONS PTO, HYDRAULIC, FRONT MOUNT, ELECTRIC

## NOZZLES



Aerospace Polymer Nozzle - Part# 2851  
Standard Clamp Band - Part# 1173



Flexible Nozzle Assembly - Part# 3345  
Various lengths available.  
Ideal for rough terrain.

Gyratory Atomizing Nozzle - Part# 2547  
(Safety guard removed for clarity)



## ALUMINUM NOZZLES

Optional aluminum nozzles **will not** connect to the standard Aerospace Polymer Nozzle (Part# 2851). Requires: **Two 45° elbow segments (Part# 1171)** and two additional clamp bands (Part# 1173).

- 12" Nozzle Extension - Part# 1468
- 15" Nozzle Extension - Part# 1842
- 20" Nozzle Extension - Part# 1845

10" Round Nozzle - Part# 1417  
12" Round Nozzle - Part# 1172  
Improves air velocity with lower horsepower and hydraulic blower units



12" Rectangular Nozzle - Part# 1469  
19" Rectangular Nozzle - Part# 1425  
5.5"x15" opening - extra length/more concentrated air flow. Uses - heavy wet debris, plugs, top dressing. **No ground clearance** in the vertical down position.



Fishtail Nozzle - Part# 1743  
5"x30" (wide angle) opening. Distributes a large volume of air at a lower velocity over a wide area. Easily converts blower into a "Greens Fan". Adaptable to all models. Not as effective at moving debris.



## 1" HYRAULIC HOSES

Part# 3922

For hydraulic machines with flow rates over 25gmp.  
Quantity needed : 2



## FORK POCKET

Part# 3894

Great for moving blowers around jobsites and bed mount / skid mount applications.



## ROTATION BEARING KIT

Part# 3838

Increases rotation speed and reduces load on rotation motor.



# BUFFALO TURBINE PRODUCTS

## CYCLONE 8000

The Cyclone 8000 Debris Blower is strategically priced to fit most budgets. This little powerhouse is already proving its worthiness in saving Time and Labor.



## MEGA

The word "MEGA" is defined as Impressive, Extreme and Mammoth. The NEW Buffalo Turbine MEGA lives up to its name!



## CYCLONE PTO

The Cyclone PTO incorporates an "Advanced" direct drive gearbox which significantly reduces routine maintenance. At 238lbs, it's the lightest, meanest turbine style PTO blower available!



## CYCLONE SQUARED

The Cyclone Squared with its "Twin Turbines", and wireless controlled dual independent nozzles, in most cases can handle twice the work in half the time. This versatile powerhouse is already a favorite on Golf courses, Racetracks, and the Paving Industry.



## CYCLONE KB4

The Cyclone KB4 with its "More Powerful" CH740 Kohler Engine and a "State of the Art" Wireless Remote System is the most powerful KB unit to date.



## HYDRAULIC

The Hydraulic debris blower features our built in "flow and pressure" control system and easily attaches to most skid steers. This handy attachment comes complete with mounting plate and hoses.

