

BUFFALO TURBINE

180 Zoar Valley Road
Springville, NY 14141

TEL: 716 592 2700 FAX: 716 592 2460

EMAIL: info@buffaloturbine.com

WEBSITE: www.buffaloturbine.com

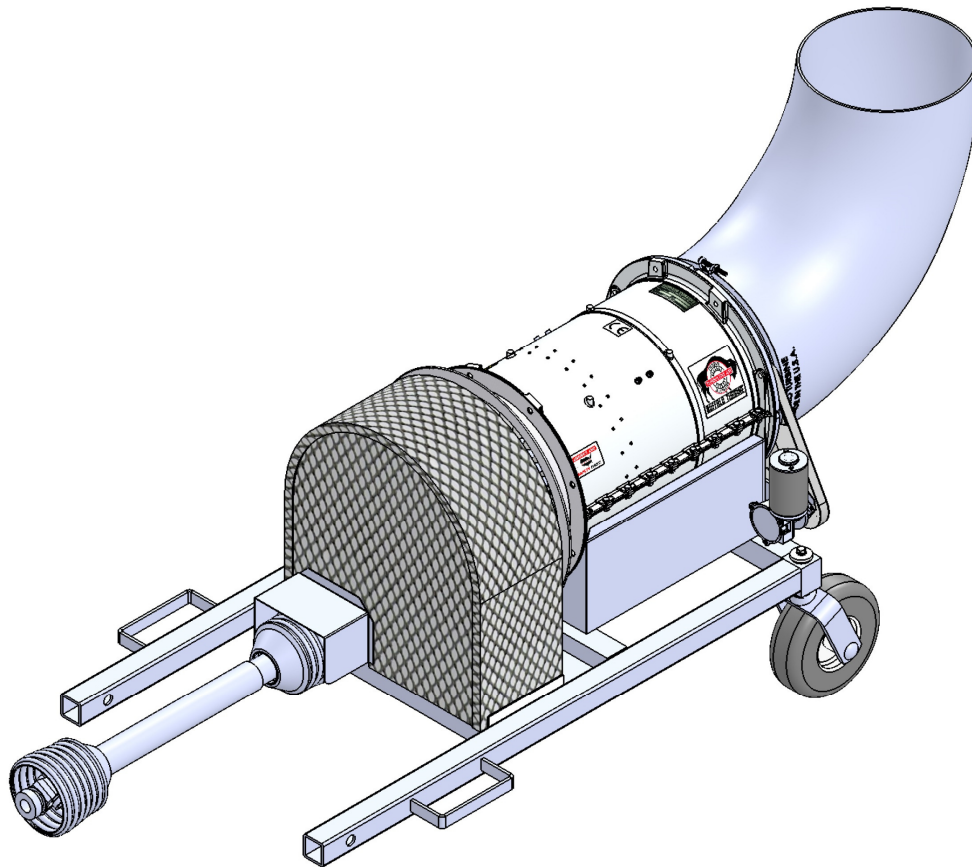

TCA24046 KIT, FM UP-STOP KIT EU(6), PARTS BAG IS RECOMMENDED (NOT INCLUDED WITH THIS MACHINE)

BUFFALO TURBINE'S BT-JD1415DB / BT-JD14SDB ORIGINAL INSTRUCTIONS AND PARTS MANUAL

03/26 -BT MAN

TABLE OF CONTENTS

Ref. Number	Description	Page Number
1.0	Introduction	2
2.0	Safety	3
2.1	Safety Decals	4
2.2	General Safety	4
2.3	Operating Safety	4
2.4	Maintenance Safety	5
2.5	Transport Safety	5
2.6	Storage Safety	5
2.7	Sign-off Form	5
3.0	Warranty Information	6
3.1	Warranty Registration Form	7
4.0	Operations	8
4.1	To the new operator or owner	8
4.2	Break-in	8
4.3	Pre-Operation Checks	8
4.4	Attaching Blower to Tractor	9
4.5	Field Operation	9
4.6	Operating RPM	9
4.7	Storage	9
5.0	Troubleshooting	10
6.0	Machine Specification	10
7.0	Maintenance	11
7.1	Maintenance Safety	11
7.2	Fluids	11
7.3	Belt Tension	11
7.4	Service Checklist	12
	Declaration of Conformity	13
	BT-JD1415DB/BT-JD14SDB Parts Reference (Serial # 22452-25856)	14
	BT-JD1415DB/BT-JD14SDB Parts Reference (After Serial # 25857)	15
	BT-JD1415DB/BT-JD 14SDB Parts Sub-Assemblies	16
	Bill of Materials for BT-JD1415DB/BT-JD14SDB	17
	Wiring Schematic Control Box	18
	Control Box Installation Instructions	19-20
	Nozzle Options	21
	Buffalo Turbine Additional Products	22

1.0 INTRODUCTION

Congratulations on your choice of a Buffalo Turbine Debris Blower. This equipment has been designed and manufactured to meet the needs of the Turf Care Industry.

Safe, efficient and trouble-free operation of your Buffalo Turbine Blower requires that you and anyone else, who will be operating or maintaining the Blower, read and understand all of the safety, operation, maintenance and troubleshooting information contained within this Operator's manual.

This Manual covers the BT-JD1415DB / BT-JD14SDB Turbine Blower.

Keep this manual handy for frequent reference and to pass on to new operators or owners. Call your Buffalo Turbine dealer or distributor if you need assistance, information, or additional copies of the manuals.

SERIAL NUMBER LOCATION

Always give your dealer the serial number of your Debris Blower when ordering parts or requesting service or other information.

The serial number plate(s) is located where indicated in the pictures below. Please document the number in the space provided for easy reference.

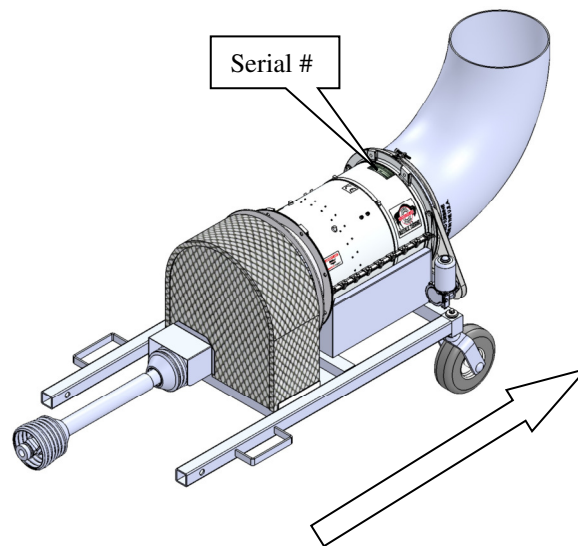

OPERATOR ORIENTATION – The directions left, right, front and rear, as mentioned throughout the manual, are as seen from the driver's seat and facing in the direction of travel.

MODEL BT-JD1415DB /BT-JD14SDB TOP SURFACE OF TURBINE ASSEMBLY

Serial Number: _____

2.0 SAFETY

YOU are responsible for the **SAFE** operation and maintenance of your Buffalo Turbine Debris Blower. **YOU** must ensure that you and anyone else, who is going to operate, maintain or work around the Buffalo Turbine Blower be familiar with the operating and maintenance procedures and related **SAFETY** information contained in this manual. This manual will take you step-by-step through your working day and alerts you to all good safety practice while operating the Blower.

Remember **YOU** are the key to safety. Good safety practices not only protect you but also the people around you. Make these practices a working part of your safety program. Be certain that **EVERYONE** operating this machine is familiar with the procedures recommended and follows safety precautions. Remember most accidents can be prevented. Do not risk injury or death by ignoring good safety practices.

- Blower owners must give operating instructions to operators or employees before allowing them to operate the Blower, and at least annually thereafter.
- The most important safety device on this equipment is a **SAFE** operator. It is the operator's responsibility to read and understand **ALL** Safety and Operating instructions in the manual and to follow these. All accidents can be avoided.
- A person who has not read and understood all operating instructions is not qualified to operate the machine. An untrained operator exposes themselves and bystanders to possible serious injury or death.
- Do not modify the equipment in any way. Unauthorized modification may impair the function and/or safety which could affect the life of the equipment.
- Think **SAFETY!** Work **SAFELY!**

This Safety Alert symbol means **ATTENTION! BECOME ALERT! YOUR SAFETY IS INVOLVED!**

The Safety Alert symbol identifies important safety messages on the Buffalo Turbine Blower and in the manual. When you see this symbol, be alert to the possibility of personal injury or death. Follow the instructions in the safety message.

Why is **SAFETY** important to you?



3 Big Reasons: Accidents Disable and Kill

Accidents Cost

Accidents Can Be Avoided

SIGNAL WORDS: Note the use of the signal words **DANGER**, **WARNING** and **CAUTION** with the safety messages. The appropriate signal word for each message has been selected using the following guidelines

1. **DANGER** –injury or death if the proper precautions are not taken.
2. **WARNING** -- A specific hazard or unsafe practice that **COULD** result in severe personal injury or death if proper precautions are not taken.
3. **CAUTION** – Unsafe practices that **COULD** result in personal injury if proper practices are not taken, or as a reminder of good safety.

The Safety Alert symbol identifies important safety messages on the Buffalo Turbine Blower and in the manual. When you see this symbol, be alert to the possibility of personal injury or death. Follow the instructions in the safety message.

2.1 SAFETY DECALS

The types of decals on the blower unit are shown below. Good safety requires that you familiarize yourself with the various Safety Decals, the type of warning and the area, or particular function related to that area that requires your **SAFETY AWARENESS.* THINK SAFETY! WORK SAFELY!**

!ATTENTION!

1. **KEEP HANDS, FEET AND CLOTHING AWAY FROM POWER DRIVEN PARTS.**
2. **STOP ENGINE AND REMOVE KEY BEFORE LEAVING OPERATOR'S POSITION.**
3. **MACHINE MUST COME TO A COMPLETE STOP BEFORE ANY MAINTENANCE, TO INCLUDE ADJUSTING, LUBRICATING OR CLEANING, IS PERFORMED.**
4. **KEEP PEOPLE AND PETS AT SAFE DISTANCE FROM MACHINE.**
5. **KEEP ALL GUARDS AND SHIELDS IN PLACE.**

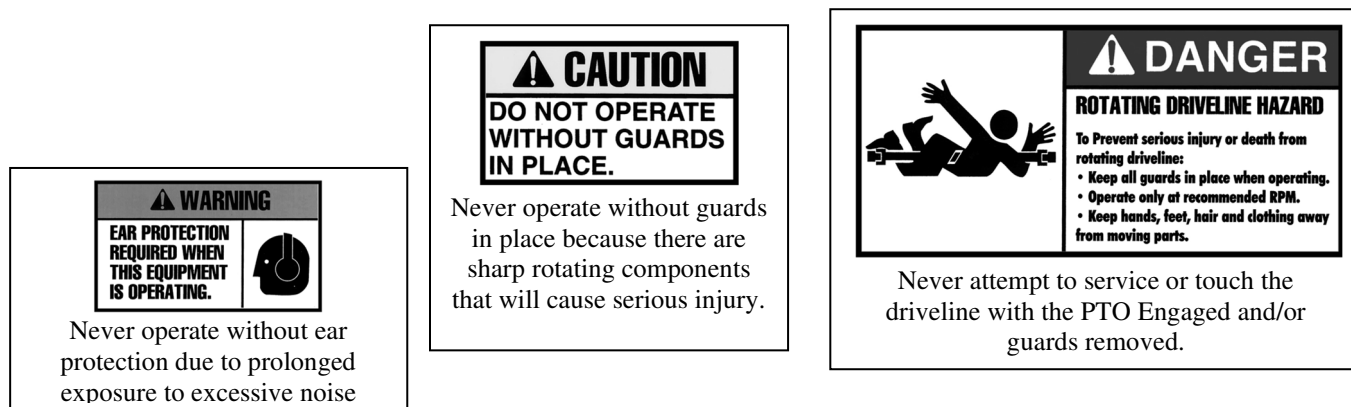

REMEMBER – If safety decals have been damaged, removed, become illegible or parts replaced without decals, new decals must be applied. New decals are available from your authorized dealer.

2.2 GENERAL SAFETY

1. Read and understand the Operator's Manual and all safety signs before operating, maintaining, and adjusting.
2. Provide a first-aid kit for use in case of an accident. Store in a highly visible place.
3. Provide a fire extinguisher for use in case of an accident. Store in a highly visible place.
4. Wear appropriate protective gear. This list includes but is not limited to:
 - A hard hat
 - Protective shoes with slip resistant soles
 - Protective glasses or goggles
 - Heavy gloves
 - Wet weather gear
 - Hearing protection
5. Do not operate without guards or shields properly installed.
6. Do not allow riders.
7. **Wear appropriate ear protection for prolonged exposure to excessive noise.**
8. **(All Models) Set Blower on the ground, stop engine, set park brake, remove ignition key and wait for all moving parts to stop before dismounting to service or adjust.**
9. Clear the area of people, especially small children, before starting the unit.
10. Review all safety related items annually with all personnel who will be operating or maintaining the Blower.
11. Keep hands, feet, hair and clothing away from moving parts. Operate equipment only while seated in the operator's seat.

2.3 OPERATING SAFETY

1. Read and understand the Operator's Manual and all safety signs before operating, servicing or adjusting.
2. Before servicing or repairing, **Set blower on the ground, disengage PTO, stop engine, set park brake, Turn Off Tractor Engine, remove key, and wait for all moving parts to stop.**
3. **We recommend using the upstop kit (on front page of manual) to prevent hitting the windshield if the cab is installed.**

Buffalo Turbine Warranty Policy

3.0 MACHINE WARRANTY INFORMATION

Buffalo Turbine warrants the DEBRIS BLOWER, to the original owner, to be free from defects in material and workmanship, under normal use and service. **All machines must have a completed registration form sent to Buffalo Turbine within 30 days of purchase for warranty to apply.** Obligation under this warranty shall extend for a period of 10 years from date of purchase and, at the option of Buffalo Turbine, replacement of any parts found, upon inspection by Buffalo Turbine, to be defective. Any parts replaced under warranty will have the remainder of the warranty from the original date of purchase.

Warranty parts during first 2 years will be shipped free of charge via standard ground shipping

If expedited shipping is required charges will be paid by the end user

Year 1: parts and labor

Year 2: parts only

Customer will be required to pay shipping charges for years 3-10

Year 3: Engine, per engine manufacturer's standard / Turbine Assembly / Frame (parts only)

Year 4-10: Turbine Assembly / Frame (parts will be prorated)

Buffalo Turbine reserves the right to incorporate improvements in material and design of its products without notice and is not obligated to make the same improvements to equipment previously manufactured.

ALL WARRANTY REPAIRS NEED PRE-APPROVAL BY A FACTORY PERSON (FROM BUFFALO TURBINE) PRIOR TO COMMENCING WITH A WARRANTY REPAIR TO INCLUDE SERIAL NUMBER AND HOURS FROM HOUR METER (IF EQUIPPED). PRE-APPROVAL WILL BE REQUIRED BY THE END USER AND DEALER/DISTRIBUTOR LEVEL.

Factory ordered Buffalo Turbine parts must be used when filing a warranty claim.

LIMITATIONS OF LIABILITY

This warranty is expressly in lieu of all other warranties expressed or implied and all other obligations or liabilities on our part of any kind or character, including liabilities for alleged representations or negligence. We neither assume nor authorize any other person to assume on our behalf, any liability in connection with the subsequent sale of the **DEBRIS BLOWER**. This warranty shall not apply to any DEBRIS BLOWER, which has been altered outside the factory in any way so as, in the judgment of Buffalo Turbine, to affect its operation or reliability, or which has been subject to misuse, neglect, or accident. This warranty does not cover parts and accessories, which are under separate guarantee from the manufacturers and service can be, obtained from their service facilities. No warranty is extended to regular service items such as lubricants, belts, paint and the like.

Original Instruction Manual

The Purchaser acknowledges having receiving training in the safe operation of the DEBRIS BLOWER and further acknowledges that Buffalo Turbine does not assume any liability resulting from the operation of the DEBRIS BLOWER in any manner other than described in the Operator's Manual supplied at the time of purchase.

WARRANTY VOID IF NOT REGISTERED (see Page 2 for warranty registration form)

DO NOT SPLIT THE TURBINE HOUSING FOR ANY REASON.

DO NOT ATTEMPT TO SERVICE OR DISASSEMBLE THE TURBINE BLOWER.

DO NOT USE THE TOP OF THE TURBINE HOUSING TO STRAP OR TIE DOWN BLOWER UNITS.

Unauthorized service work on the Turbine Blower will null and void all warranties.

If there are any questions regarding any of our products call Buffalo Turbine at 716 592 2700.

3.1 Warranty Registration Form

BUFFALO TURBINE

WARRANTY REGISTRATION FORM & INSPECTION REPORT

Any units not registered with Buffalo Turbine are not eligible for warranty claims
This form must be filled out by the dealer and signed by both the dealer and the customer at the time of delivery

Customer's Name _____ Dealer's Name _____

Address _____ Address _____

City, State, Zip, Country _____ City, State, Zip, Country _____

Email Address (important) _____ Email Address _____

Telephone Number _____

Blower Model _____

Circle one:

Serial Number _____

Commercial Use

Delivery Date _____

Private Use

DEALER INSPECTION REPORT

SAFETY CHECKS

_____ Tire Pressure Check -- Model KB

_____ All Decals Installed

_____ Wheel Bolts

_____ Review Operating and Safety Instructions

_____ Belt Tension

_____ Guards in Place

_____ Lubricate Machine

_____ Fasteners Tight

_____ Trailer assembly bolts properly installed and tightened

ALL 3 POINT HITCH MODELS: PTO SHAFTS MUST TELESCOPE IN EVERY POSITION

I have thoroughly instructed the buyer on the above described equipment which reviews the included Operator's Manual content, equipment care, adjustments, safe operation and applicable warranty policy.

Date _____

Dealer's Rep. Signature _____

The above equipment and Operator's Manual has been received by me and I have been thoroughly instructed as to the care, adjustments, safe operation and applicable warranty policy.

Date _____

Owner's Signature _____

PLEASE EMAIL TO BUFFALO TURBINE AT - service@buffaloturbine.com

Or fax to 716 592 2460

4.0 OPERATIONS

4.1 TO THE NEW OPERATOR OR OWNER

Buffalo Turbine Debris Blowers are designed to quickly and efficiently, blow away leaves, cuttings and other debris. The material is conveyed on a stream of high volume and velocity of air to remove it from the area of concern. When the material is removed, it gives a neat, professional look to the working area.

Many of the features incorporated into the machine are the result of suggestions made by customers like you. Read the manual carefully to learn to operate the machine safely and how to set it to provide maximum efficiency. The manual will take you step-by-step through your working day. By following the operating instructions in conjunction with a good maintenance program, your Blower will provide many years of trouble-free service.

Potential Mechanical Hazards while operating your machine:

Never operate the debris blower around others to prevent the possibility of being run over by equipment.

Never ride on your debris blower to prevent the possibility of being thrown off the machine or hurt severely.

Potential Crushing Hazards while operating your machine:

Between tractor arms and blower frame arms

Between tractor deck and blower guard shroud

Between tractor deck and tractor arms

Between Pin at the end of the mounting arms

Between caster wheels and the ground



WARNING:

This Product can expose you to chemicals which are known to the State of California to cause cancer and birth defects or other reproductive harm.

For more information go to www.P65Warnings.ca.gov.

4.2 BREAK-IN

Although there are no operational restrictions on the Blower when it is used for the first time, it is recommended that the following mechanical items be checked:

A. Operating for first ½ hour

1. Re-torque all wheel bolts, axle nuts and trailer mounting bolts and nuts.
2. Re-torque all other fasteners and hardware.
3. Check set screw (nozzle pulley) to ensure it tightened.

B. Operating for first 5 hours

1. Re-torque all hardware and fasteners.
2. Check set screw (nozzle pulley) to ensure it tightened.
3. Go to the normal servicing and maintenance schedule as defined in the Maintenance Section of the manual.

4.3 PRE-OPERATION CHECKS

Efficient and safe operation of the Buffalo Turbine Blower requires that each operator reads and understands the operating procedures and all related safety precautions outlined in this section. A pre-operation checklist is provided for the operator. It is important for both personal safety and maintaining the good mechanical condition of the machine that this checklist is followed.

Before Operating the Blower and each time thereafter, the following areas should be checked off.

1. Make sure all guards and shields are in place, secured and functioning as designed.
2. Lubricate machine per maintenance schedule.
3. Ensure that the machine is properly attached to the (appropriate) power unit attaching arms and that the mounting pins are secured in position.
4. Ensure the PTO driveline is securely attached and can telescope easily.
5. Check that all clamp bands are secure.
6. Check the belts and pulleys for proper tension and alignment.

4.4 Attaching Blower to Tractor

1. Make sure the tractor has proper HP and is in good working order, including mounting brackets, PTO output shaft, and safety equipment.
2. Make sure there is enough room to safely drive up to the blower. Align mounting arms of the blower unit to match the tractor mounting brackets of the tractor (underside of tractor). Engage into the mounting brackets and secure pins. (See Tractor attachment installation instructions)
3. Connect PTO shaft. **NEVER attempt to maintain or attach PTO shaft while tractor is running!**
4. Check Upper and lower limits.
5. Check that the caster wheels turn and roll freely.
6. Connect the remote nozzle control to a 12 volt system only (see PG.19). White wire needs to be connected to positive terminal of battery. Black wire needs to be connected to negative terminal of battery. (wiring schematic on PG. 18)
7. To unhook the blower unit from the tractor, reverse the above procedures. Always park the Blower unit and tractor in a dry, level area.

4.5 FIELD OPERATION

1. Do not direct debris blower towards people, pets, autos, windows, etc.
2. **Starting blower unit:** Always engage the tractor PTO control at a lower engine speed with nozzle pointed down or away.
3. The air stream direction is changed (in either direction) by moving the rocker switch located on the hand control box. The nozzle will stop turning by releasing the rocker switch. **ALWAYS CHECK THE GROUND CLEARANCE WHEN OPERATING THE NOZZLE IN THE DOWN VERTICAL POSITION.**
4. **Stopping blower unit:** Gradually slow the tractor RPM down to a lower speed using the throttle.
5. Disengage PTO and allow the blower fan speed to come to a stop.

NOTE: Make sure the control box wire harness is clear of all moving parts including the PTO shaft.

4.6 Operating RPM (All Models)

The manufacturer's tractor section normally recommends the unit be run at a RPM that will insure efficient attachment operation and hydrostatic drive functioning. The Blower can operate at a slower RPM if it can effectively move the debris.

Vary ground speed with the hydrostatic transmission. Increase engine RPM to improve tractor efficiency.

Moving light material, such as dry leaves, requires much less wind than wet or heavier material.

Always try to blow with the wind. The Blower can be used for a wide variety of applications to move leaves, grass clippings, aeration plugs and debris. Drying wet areas has been another use with these powerful Debris Blowers.

4.7 Storage

At the end of the working season or before storing the blower unit, prepare the machine by following this procedure:

1. Select a storage area that is dry, level and free of debris.
2. Thoroughly wash the machine with a water hose to remove all debris and residue.
3. Run the machine at low RPM to dry the Blower Components.
4. Touch up all paint chips and scratches to prevent rusting.
5. Inspect for worn or failed components. Order the replacement parts and repair the blower unit when time allows. This will eliminate unnecessary down time at the start of next season.
6. Store in an enclosed building. If space is not available, cover with a waterproof tarpaulin and tie it down securely.
7. Store the machine away from areas of human activity.
8. Do not allow children to play around the stored unit.

5.0 TROUBLE SHOOTING

The Buffalo Turbine Debris Blower uses a high volume and velocity of air to move material from one place to another. The system is simple and reliable requiring minimal maintenance.

If you encounter a problem that is difficult to solve, even after reading through this trouble shooting section, please call your local dealer or distributor. **Before calling, please have this Operator's Manual and the serial number from your Blower ready.**

In the following section, we have listed causes and solutions to the problems that you may have encountered.

TURN OFF ENGINE, REMOVE KEY, AND DISCONNECT BATTERY BEFORE SERVICING BLOWER UNITS. INSTALL GUARDS BEFORE OPERATING.

PROBLEM	CAUSE	SOLUTION
No air flow	Buildup of debris inside turbine	Remove nozzle and clean debris from inside turbine
	Broken coupling (KB Series)	Replace coupling
No air flow	Blower fan not turning	See solutions above
Reduced or no air flow	Blower fan turns	Air intake or exhaust restricted Shut off engine Blower or tractor – remove restrictions Debris cannot be allowed to build up between the blower fan and stationary vanes
Machine vibrates or Unusual sounds	Bearing or coupling failure Out-of-balance	Replace bearings or coupling Have your dealer check blower for damaged blades. Wash and clean blower fan blades

6.0 Machine Specifications

Model JD1415DB / BT-JD14SDB Series

Length: 70" With nozzle (from end of mounting arms to end of nozzle)

Width: 36" With caster wheels

Height: 30" With caster wheels

Weight: 215 lbs

Electrical System: 12 Volt

Input Power: PTO

Outlet Size: Approximately 12"

Ballasting: Refer to Tractor manual for proper ballasting procedures.

7.0 MAINTENANCE SECTION

7.1 Maintenance Safety

1. Set Blower on a level surface, stop engine, set park brake, remove ignition key and wait for all moving parts to stop before dismounting to service, adjust or repair.
2. Reinstall and secure all guards removed for servicing before starting to use machine again. *We recommend wearing gloves when removing or installing the guard to avoid getting cut*
3. Securely support machine with blocks or safety stands when changing tires or working beneath it.

7.2 Fluids

Pillow Block Bearings require NLGI2 grease

Grease driveline per operator manual (included with the driveline)

A Teflon or Silicone spray type lubricant on the nozzle base and slides provides for freer rotation.

7.3 Belt Tension

Efficient machine operation requires that the belt be properly tensioned. To adjust the belt tension, follow this procedure:

1. Remove guard (item 20) after PTO is disengaged and tractor is shut off.
1. Loosen #1 and #2 pillow blocks (2 bolts each). Keep a slight tension on bolts.
2. Loosen lock nut (item 19). Adjust drive screws (item 18) (located at the base of the pillow blocks) equally on each pillow block to achieve proper tension. See specification below.
3. Check pulley alignments with a precision straight edge, and then tighten pillow blocks. Recheck belt tension and pulley alignment.
4. Attach safety guard, start tractor and engage PTO. Listen and visually check for any belt slippage and check for any misalignment.

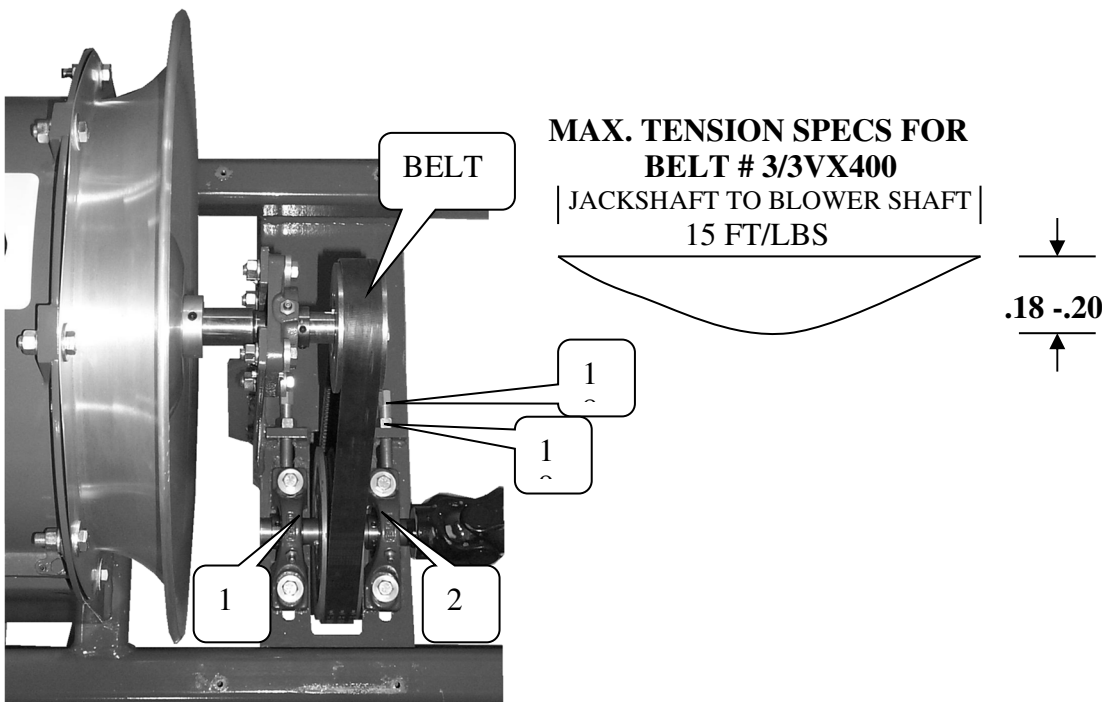

Caution: A loose belt will cause premature wear an inhibit performance.

Pillow Block Bearings and Flange bearing require 2-3 shots of grease every 40HRS. *Make sure hands are clear of belt and pulley at all times*

7.4 SERVICE CHECKLIST

See Lubrication and Maintenance sections for details of service. Copy this page to continue record.

TURN OFF TRACTOR, REMOVE KEY & DISCONNECT WIRE HARNESS BEFORE SERVICING BLOWER UNIT

CODE: LUBRICATE-(L) / CHECK-(*) / CHANGE-(C) / REPLACE-(B) / CLEAN-(CL)

SCHEDULED MAINTENANCE HOURS _____

SERVICED BY _____

MAINTENANCE

8 hrs or daily

- (*) Remove all debris that has settled between the blower wheel fan and the stationary vanes. Helps maintain peak performance.
- (L) PTO Driveline (per operators manual included with driveline)
- (*) Check Clamp Band Bolt for tightness

40 hours or weekly

- (*) Check condition of belts
- (L) Nozzle base slides (Teflon or Silicone spray)
- (L) Pillow Block and Flange Bearing (2-3 shots of grease)
- (*) Check set screw (nozzle pulley) to ensure it is tightened
- (*) Wash and Clean any dirt or grime build up that has accumulated on blower wheel fan blades. Helps to minimize vibration balance and maintain peak performance.

200hrs or annually

- (CL) Machine

DO NOT OPERATE BLOWER UNIT WITHOUT GUARDS SECURELY ATTACHED

*Debris Blowers, Vector Sprayers, Dusters
and Dust Control Systems*

Declaration of Conformity

According to EC Machinery Directive 2006/42/EC, Annex II B

We, Buffalo Turbine of Springville, New York, USA herewith declare, that the following described machine/machinery part is to be incorporated into a(n) machine/assembly with other machinery to make one machine and that its setting into operation is prohibited unless the machine, which shall be incorporated into the lower mentioned, complies with the requirement of the EC Machinery Directive 2006/42/EC.

Product: Debris blower

Type: JOHN DEERE

Applicable EC Directives: Machinery Directive 2006/42/EC

Applicable Harmonized Standards: BSENISO 12100:2010

BT-JD1415DB / BT-JD14SDB PARTS REFERENCE

(SERIAL # 22452 - 25856)

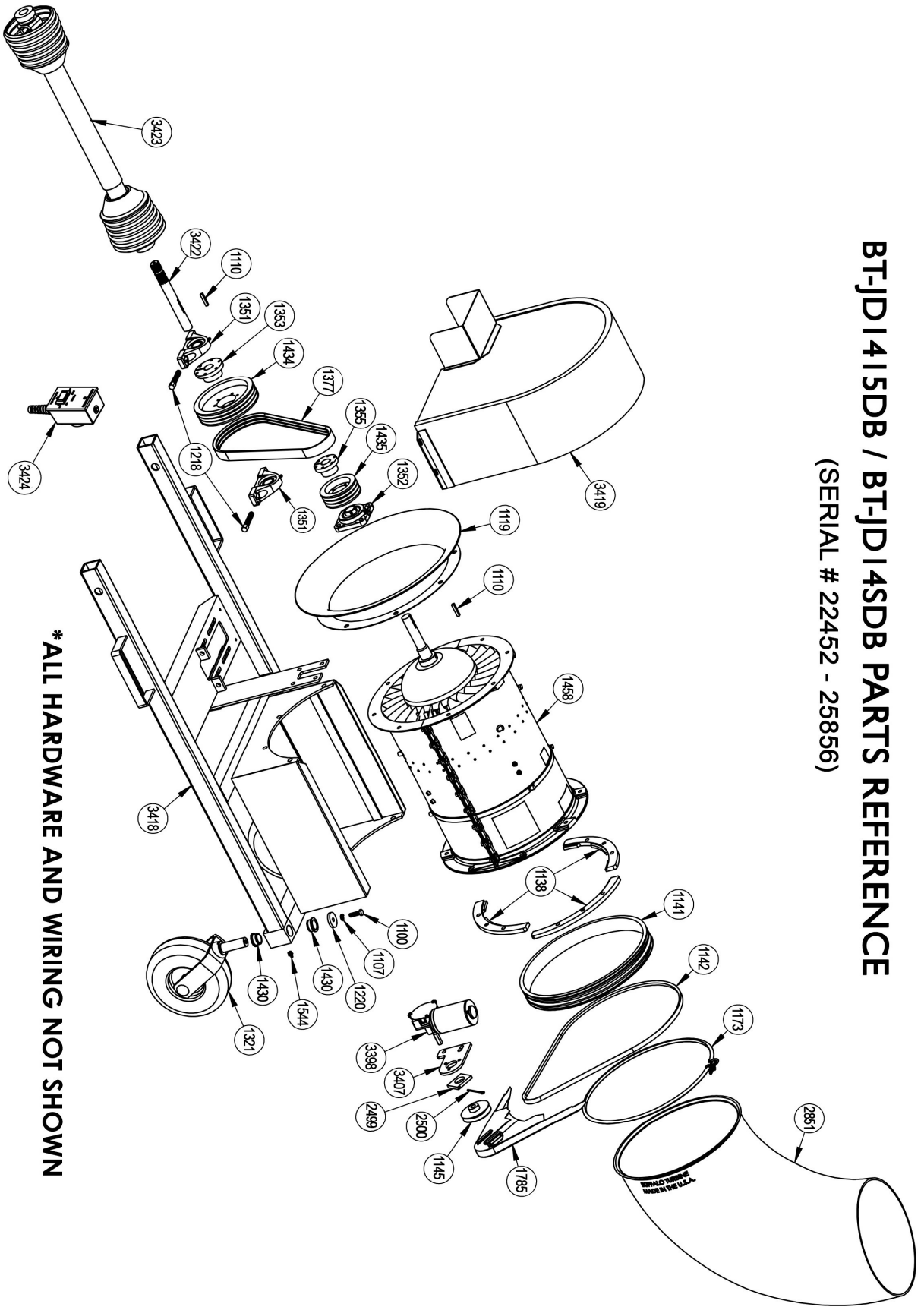

*** ALL HARDWARE AND WIRING NOT SHOWN**

BT-JD1415DB / BT-JD14SDB SUB ASSEMBLIES PARTS REFERENCE (AFTER SERIAL #22452)

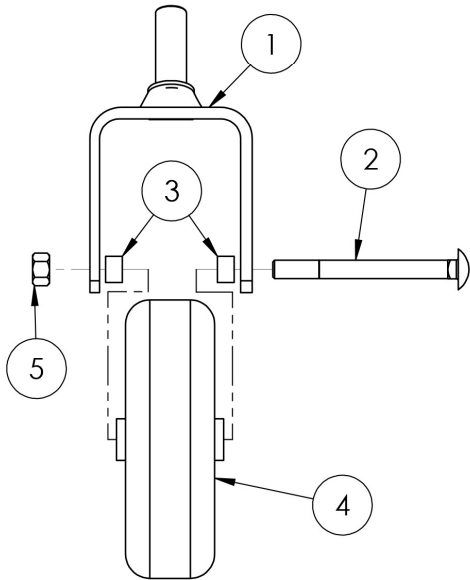

PART # 1321 : CASTER WHEEL ASSEMBLY			
Ref #	Qty.	Description	Part #
1	1	YOKE WELDMENT, PAINTED BLACK	1580
2	2	5/8-11 x 6" CARRIAGE BOLT ZINC PLATED	1545
3	2	BUSHING, 5/8" LONG	1431
4	1	9 X 3.50-4 TIRE AND RIM ASSY	1822
5	1	5/8-11 SIDELOCK NUT ZINC PLATED	1546

PART # 3424 : WIRING HARNESS			
Ref #	Qty.	Description	Part #
6	2	6-32 PHILLIPS FLAT HEAD SCREW 1/2" LONG, SS	1279
7	1	ROCKER SWITCH	1769
8	1	SEAL, ROCKER SWITCH	4013
9	1	NOZZLE CONTROL BOX COVER	1304
10	1	SEAL, CONTROL BOX COVER	4014
11	1	1/4-20 NUT PLATE	1302
12	1	FLEX TYPE STRAIN RELIEF CONNECTER	TT-593C
13	1	CONTROL BOX HOUSING	1281
14	1	MAGNET	1300
15	1	1/4-20 X 3/4 HHCS	1258

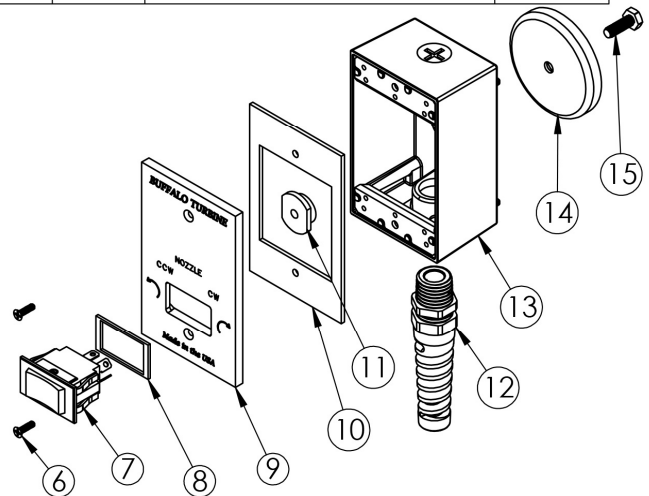

NOTE: NOT SHOWN BUT INCLUDED WITH PART #3424

Part #	Description	Qty.
1177	1/4 BLACK HEAT SHRINK	12 in.
1178	3/8 BLACK HEAT SHRINK	24 in.
1282	QUICK CONNECT FLAG TERMINAL	4
1283	BUTT CONNECTOR	5
1285	EYE CONNECTOR	2
1305	16/4 SJO WIRE	54 in.
1537	16-2 SJOOW CORD	84 in.
1838	1/2 HEAT SHRINK	8 in.
3414	15 AMP FUSE	1
3427	2-WAY WEATHER PACK CONNECTOR, FEMALE	1
3428	2-WAY WEATHER PACK CONNECTOR, MALE	1
3430	16-14 GA. MALE WEATHER PACK TERMINAL	2
3431	GREEN CAVITY SEAL	2
3432	GREEN CAVITY PLUG	2
3522	FUSE HOLDER	1

BILL OF MATERIALS FOR BT-JD1415DB / BT-JD14SDB			
REF PAGE #	PN	DESCRIPTION	QTY
	1100	3/8-24 X 1-1/4 HHCS ZINC GR 5	6
	1101	3/8-24 X 1-1/2 HHCS ZINC GRADE 5	7
	1102	3/8-24 X 1-3/4 HHCS ZINC	7
	1105	3/8-24 HEX NUT ZINC PLATED GRADE 5	18
	1107	3/8 LOCK WASHER ZINC PLATED	24
	1108	3/8 FLAT WASHER ZINC PLATED	22
	1110	KEY, 1/4 X 1-1/2	2
	1116	1/4-14 X 1 HEX HEAD WASHER SELF TAPPING	1
15	1119	14-221-D1 BELLMOUTH	1
	1130	SET SCREW	1
15	1142	AX54 V-BELT	1
15	1145	ROTATION PULLEY	1
	1156	SERIAL TAG	1
	1167	COV 5/16 X 1/4 WIRE CLAMP	2
15	1173	CLAMP BAND W/ BOLT & NUT	1
	1182	4 X 4 BT Decal	2
	1186	CAUTION DO NOT OPERATE DECAL	2
	1187	8 X 10 BT DECAL	2
15	1218	BOLT, 1/2 PUSHOVER	2
15	1220	RETAINER WASHER 3/8 X 1-5/8	2
	1228	ROTATING DRIVE HAZARD DECAL	1
	1233	AMERICA & SAFETY FIRST DECAL	1
	1236	3/16 X 1 ROLL PIN	2
	1237	1/2-20 HEX NUT	2
	1258	1/4-20 X 3/4 HHCS	4
	1259	1/4 LOCKWASHER	7
15	1351	1" PILLOWBLOCK BEARING	2
15	1352	1" FLANGE BEARING	1
15	1353	1" SDS BUSHING	1
15	1355	1"SH BUSHING	1
15	1377	3/3VX400 POWERBAND BELT	1
	1415	1/2" FLAT WASHER	7
15	1430	CASTER BUSHING	4
	1431	BUSHING 5/8 LONG	4
15	1434	3/3V690SDS SHEAVE	1
15	1435	3/3V4.12SH SHEAVE	1
	1499	NUT PLATE 3/8	4
	1544	1/8"NPT STRAIGHT GREASE FITTING	2
	1545	5/8-11 X 6" CARRIAGE BOLT	2
	1546	5/8-11 SIDELOCK NUT	2
	1580	YOKE WELDMENT	2
	1783	CE LABEL	1
15	1785	GUARD ROTATION MOTOR BELT	1
	1822	CASTER WHEEL ASSEMBLY	2
	2023	16/14 FULLY INSULATED MALE QUICK DISCONNECT	2
	2076	16/14 FULLY INSULATED FEMALE QUICK DISCONNECT	2
15	2499	PLASTIC BELT GUARD MOUNT	1
15	2500	1/8 X 2 1/2" COTTER PIN	1
15	2851	AEROSPACE POLYMER NOZZLE	1
	3152	1/4-28 x 1" LONG HHCS GRADE 5	3
	3384	NYLON SELF-RETAINING WASHER	4
15	3398	ROTATION MOTOR, 12V	1
15	3407	ROTATION MOTOR BRACKET	1
15	3418	JD1415 FRAME	1
15	3419	GUARD-JD1415DB	1
15	3422	SPLINED STUB SHAFT-JD1415DB	1
15	3423	WALKERSHED PTO DRIVELINE	1
15	3424	WIRE HARNESS-JD1415DB	1
	3427	2 WAY WEATHER PACK CONNECTOR	1
	3429	16-14 GA FEMALE WEATHER PACK	2
	3431	20-18 GA GREEN CAVITY SEAL	2
15	3836	3/8"-24 X 2" LONG FHCS	4
15	3837	ELBOW BASE RING BEARING	4
15	3843	BEARING BUSHING	4
	4725	WARNING-COMBINED EAR/EYE PROTECTION & THROWN OBJECT DECAL	1
15	5498	JD BLOWER ASSEMBLY	1
14	5577	BEARING SPACER (BACK SIDE OF TURBINE HOUSING)	4
14	5622	THICK-FLANGE BASE RING KIT (INCLUDES BASE RING, BEARINGS, BUSHINGS AND HARDWARE)	1

WIRING SCHEMATIC CONTROL BOX (AFTER SERIAL #22452)

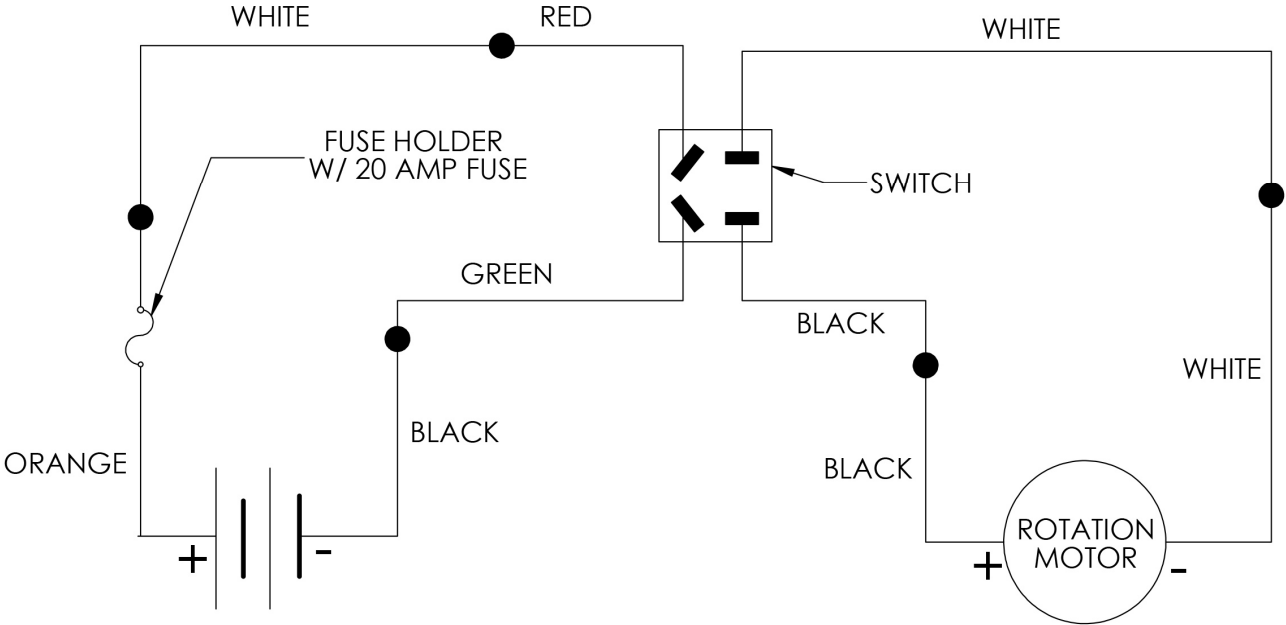

Control Box Installation Instructions for 1400/1500 Series II Tractors

1. First you will need to mount the control box onto the tractor. This will be done using the magnet already attached to the control box. The best place to mount the control box is under the seat as shown in Fig. 1. Run the wiring along the side of the seat to the back as shown in Fig. 2. Run the wiring under the seat and go through the same hole as the tractors wires.



Fig. 1



Fig. 2

2. Next the control box wires will need to be zip-tied to the wires of the tractor as shown in Fig. 3.



Fig. 3

3. Depending on the model of the tractor (1400/1500 Series II), the routing will be slightly different due to differences of the layout on each model.

- 1400 Series II: Since the battery is right under the seat, the wire needs to be run along with the tractor wires to take up its length (Fig. 4). In addition, the wire to connect to the blower must now be run to the front of the tractor guided along with the tractors existing wiring. (Fig.4 & 5)

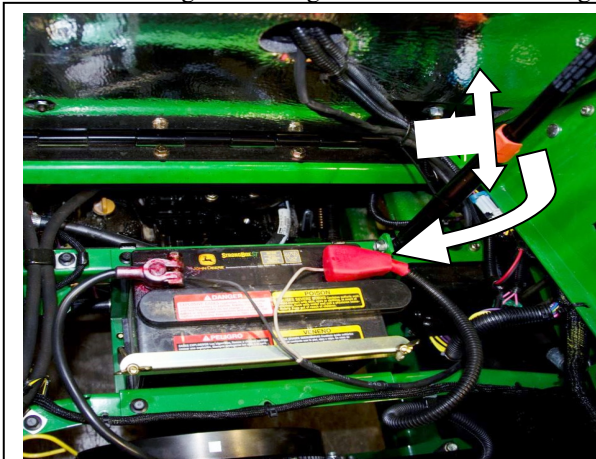

Fig. 4

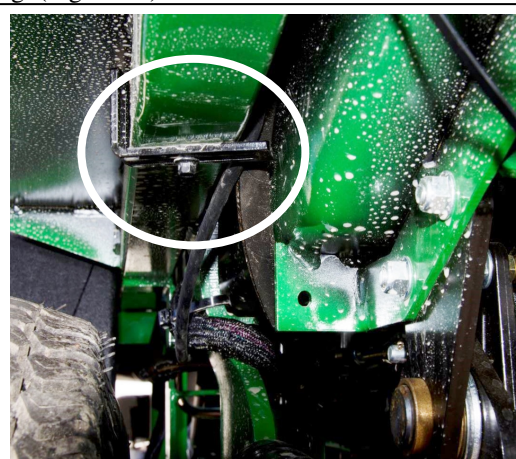

Fig. 5 (Use wire retainer already on tractor)

- 1500 Series II: The battery is mounted next to the engine. The control box wiring needs to be run along the tractors other wiring then down to battery in order to be connected (Fig 6 & 7). In addition, the wire that connects to the blower must run to the front of the tractor guided along with the tractors already existing wiring and then zip-tied together. (Fig. 8). *There is a channel on certain models that the wire can be run through as well.

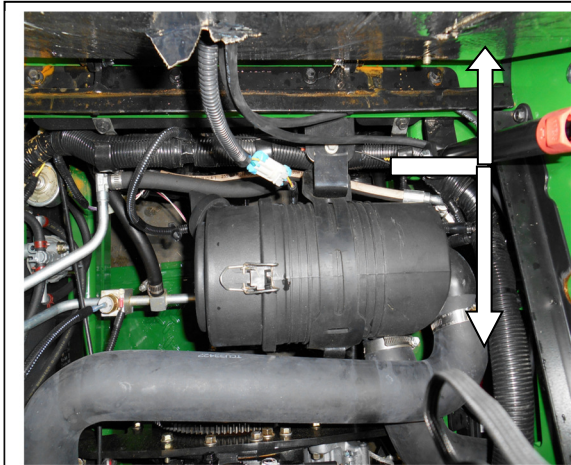

Fig. 6



Fig. 7

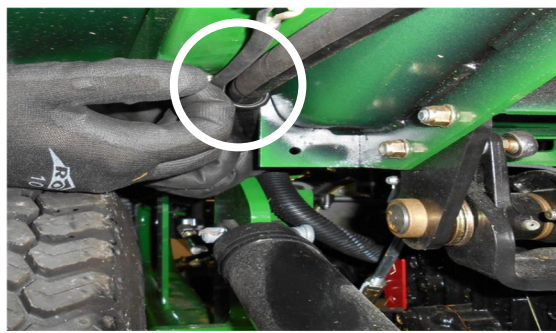

Fig. 8

4. Last step is to remove the dust cover on the control box wire and then connect it to the mating connector on the blower harness. (Fig. 9).



Fig. 9



OPTIONS

180 Zoar Valley Road
 Springville, NY 14141

NOZZLES +

Aerospace Polymer Nozzle - Part# 2851



Flexible Nozzle Assembly - Part# 3345
 Various lengths available.
 Ideal for rough terrain.

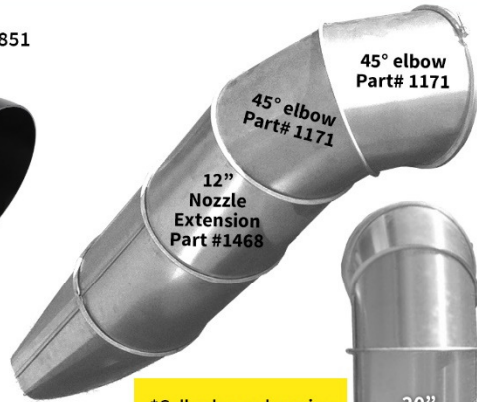

*Call sales and service to request custom nozzle configuration.



Gyratory Atomizing Nozzle - Part# 2547
 (Safety guard removed for clarity)



ALUMINUM NOZZLES

Optional aluminum nozzles **will not** connect to the standard Aerospace Polymer Nozzle (Part# 2851). Requires: **Two 45° elbow segments (Part# 1171)** and two additional clamp bands (Part# 1173).

12" Extension - Part# 1468
20" Extension - Part# 1845

10" Round Nozzle - Part# 1417
12" Round Nozzle - Part# 1172
 Improves air velocity with lower horsepower and hydraulic blower units



10" Rectangular Nozzle - Part# 1469
19" Rectangular Nozzle - Part# 1425
 5.5"x15" opening - extra length/more concentrated air flow. Uses - heavy wet debris, plugs, top dressing. No ground clearance in the vertical down position.



Fishtail Nozzle - Part# 1743
 5"x30" (wide angle) opening. Distributes a large volume of air at a lower velocity over a wide area. Easily converts blower into a "Greens Fan". Adaptable to all models. Not as effective at moving debris.



CLAMP BAND W/ BOLT & NUT

Part# 1173



QUICK CONNECT CLAMP BAND

Part# 4935

Quickly remove or add nozzle with the barrel style clamp band.



FORK POCKETS

Part# 4552

Great for moving blowers around jobsites and bed mount / skid mount applications.



WARNING:
 Cancer & Reproductive Harm -
 www.P65Warnings.ca.gov

BUFFALO TURBINE PRODUCTS

Cyclone eKB



Cyclone 8000 (& 8000 EFI)



Cyclone KB7



Cyclone MEGA



The Original & Most Powerful Turbine Debris Blowers
since 1945



BLITZ (& BLITZ MEGA)



Cyclone SQUARED



Cyclone Hydraulic (& Hydraulic MEGA)



Cyclone PTO (& PTO MEGA)

Visit BuffaloTurbine.com for more product info