

BUFFALO TURBINE LLC

180 Zoar Road
Springville, NY 14141
TEL: 716 592 2700 FAX: 716 592 2460
EMAIL : info@buffaloturbine.com
www.buffaloturbine.com

Model CSM2G with
Optional Trailer Package

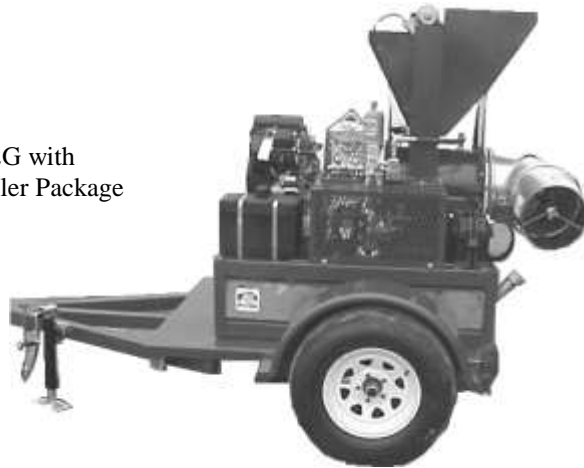

Model CSM2 mounted
To a track vehicle

BUFFALO TURBINE'S MODEL BT-CSM2G SPRAYER / GRANULAR OPERATOR'S MANUAL AND PARTS BOOK

02/26-BT MAN

BUFFALO TURBINE SPRAYERS MODEL CSM2

WARRANTY REGISTRATION FORM & INSPECTION REPORT

WARRANTY REGISTRATION

This form must be filled out by the dealer and signed by both the dealer and the customer at the time of delivery

Customer's Name _____ Dealer Name _____
Address _____ Address _____
City, State, Code _____ City, State, Code _____
Telephone Number _() _____
Email Address _____
Sprayer Model _____ Circle one:
Serial Number _____ Commercial Use
Delivery Date _____ Private Use

DEALER INSPECTION REPORT

_____ Tire Pressure Check – Trailer Model
_____ Wheel Bolts
_____ Belt Tension
_____ Lubricate Machine
_____ Fasteners Tight

SAFETY CHECKS

_____ All Decals Installed
_____ Review Operating and
Safety Instructions
_____ Guards in Place and secure

I have thoroughly instructed the buyer on the above described equipment which review the included Operator's Manual content, equipment care, adjustments, safe operation and applicable warranty policy.

Date _____ Dealer's Rep. Signature _____

The above equipment and Operator's Manual has been received by me and I have been thoroughly instructed as to the care, adjustments, safe operation and applicable warranty policy.

Date _____ Owner's Signature _____

FAX A COPY OF THIS FORM TO BUFFALO TURBINE AT 716 592 2460

SERIAL NUMBER LOCATION

Always give your dealer the serial number of your Sprayer and/or optional Duster when ordering parts or requesting service or other information.

The serial number plate(s) is located where indicated in the picture below. Please document the number in the space provided for easy reference.

Model CSM2 Sprayer

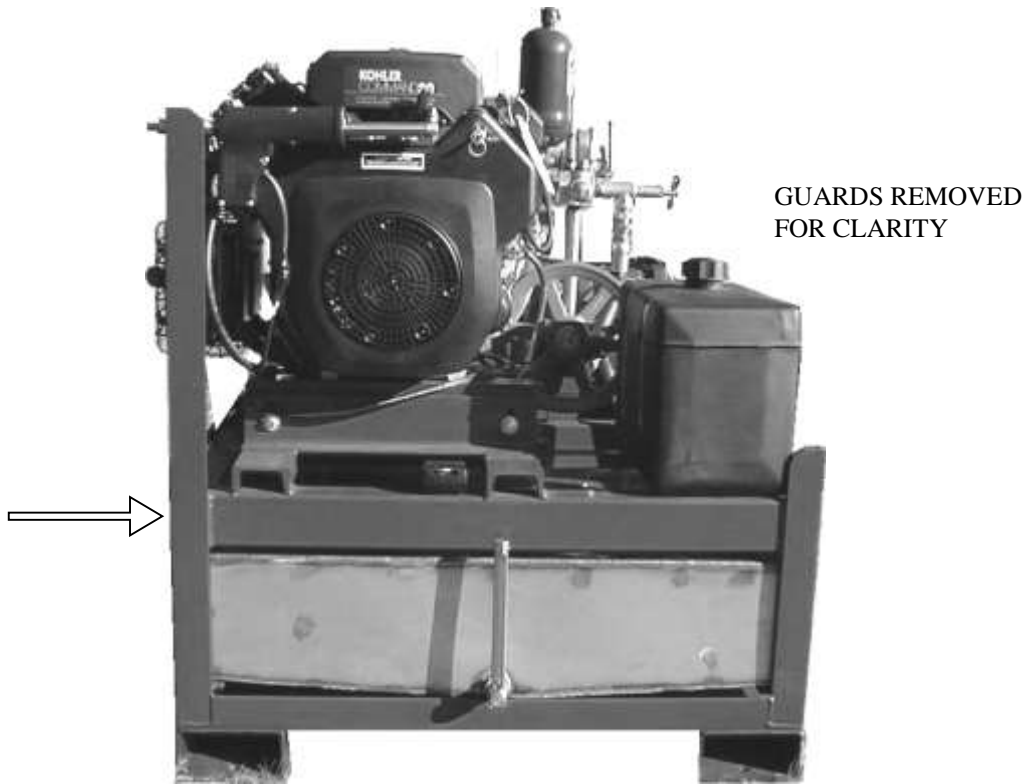

Serial number location (sitting in the operator's seat)
(right front side of frame below the muffler)

Serial Number _____

BUFFALO TURBINE

DEBRIS BLOWERS

WARRANTY

Buffalo Turbine LLC warrants the **Model CSM2G** to be free from defects in material and workmanship, under normal use and service. Obligation under this warranty shall extend for a period of 1 year (12 months) and shall be limited to, at the option of Buffalo Turbine, replacement of any parts found, upon inspection by Buffalo Turbine, to be defective.

WARRANTY CLAIMS

The purchaser claiming under this warranty shall submit a warranty claim in the prescribed form to Buffalo Turbine or an Authorized Dealer, for inspection by an authorized company representative.

LIMITATIONS OF LIABILITY

This warranty is expressly in lieu of all other warranties expressed or implied and all other obligations or liabilities on our part of any kind or character, including liabilities for alleged representations or negligence. We neither assume nor authorize any other person to assume on our behalf, any liability in connection with the subsequent sale of the **Model CSM2G**.

This warranty shall not apply to any Sprayer or optional Duster, which has been altered outside the factory in any way so as, in the judgement of Buffalo Turbine, to affect its operation or reliability, or which has been subject to misuse, neglect, or accident.

This warranty does not cover parts and accessories, which are under separate guarantee form the manufacturers and service can be, obtained form their service facilities. No warranty is extended to regular service items such as lubricants, belts, paint and the like.

OPERATION MANUAL

The Purchaser acknowledges having received training in the safe operation of the Sprayer or optional Duster and further acknowledges that Buffalo Turbine does not assume any liability resulting from the operation of the Sprayer/Duster in any manner other than described in the Operator's Manual supplied at the time of purchase.

WARRANTY VOID IF NOT RESGISTERED

1 INTRODUCTION

Congratulations on your choice of a Buffalo Turbine Sprayer and/or Duster. This equipment has been designed and manufactured to meet the needs of the Insect Control Industry.

Safe, efficient and trouble-free operation of your Buffalo Turbine Unit requires that you and anyone else who will be operating or maintaining this unit, read and understand all of the safety, operation, maintenance and trouble shooting information contained within this Operator's manual.

This Manual covers the Model CSM2G.

Keep this manual handy for frequent reference and to pass on to new operators or owners. Call your Buffalo Turbine dealer or distributor if you need assistance, information, or additional copies of the manuals.

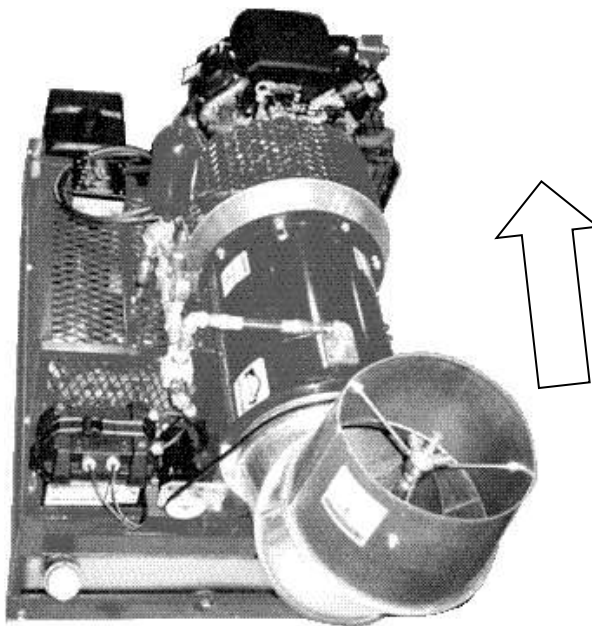

Top View of the Model CSM2

OPERATOR ORIENTATION – The directions left, right, front and rear, as mentioned throughout the manual, are as seen from the driver's seat and facing in the direction of travel.

2 SAFETY

SAFETY ALERT SYMBOL

This safety Alert symbol means **ATTENTION! BECOME ALERT! YOUR SAFETY IS INVOLVED!**

The Safety Alert symbol identifies important safety messages on the Buffalo Turbine Sprayer or Duster and in the manual. When you see this symbol, be alert to the possibility of personal injury or death. Follow the instructions in the safety message.

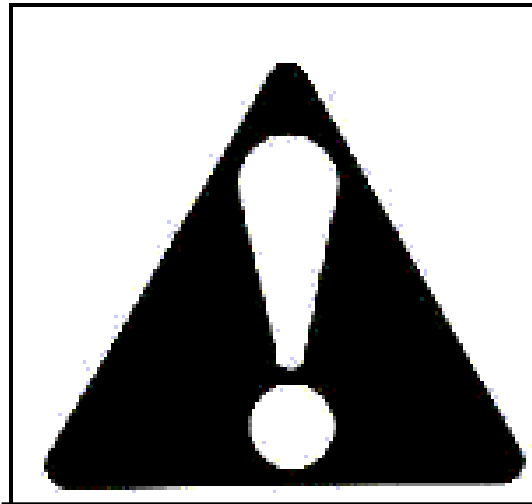

Why is SAFETY important to you?

3 Big Reasons:

- Accidents Disable and Kill**
- Accidents Cost**
- Accidents Can Be Avoided**

SIGNAL WORDS: Note the use of the signal words **DANGER**, **WARNING** and **CAUTION** with the safety messages. The appropriate signal word for each message has been selected using the following guidelines:

1. **DANGER** – An immediate and specific hazard which **WILL** result in severe personal injury or death if the proper precautions are not taken.
2. **WARNING**- A specific hazard or unsafe practice which **COULD** result in severe personal injury or death if proper precautions are not taken.
3. **CAUTION** – Unsafe practices which **COULD** result in personal injury if proper practices are not taken, or as a reminder of good safety.

SAFETY

YOU are responsible for the **SAFE** operation and maintenance of your Buffalo Turbine Sprayer or Duster. **YOU** must ensure that you and anyone else who is going to operate, maintain or work around the Buffalo Turbine unit be familiar with the operating and maintenance procedures and related **SAFETY** information contained in this manual. This manual will take you step-by-step through your working day and alerts you to all good safety practice while operating this unit.

Remember **YOU** are the key to safety. Good safety practices not only protect you but also the people around you. Make these practices a working part of your safety program. Be certain that **EVERYONE** operating this machine is familiar with the procedures recommended and follows safety precautions. Remember most accidents can be prevented. Do not risk injury or death by ignoring good safety practices.

- Sprayer/Duster owners must give operating instructions to operators or employees before allowing them to operate this unit, and at least annually thereafter per OSHA (Occupational Safety and Health Administration) regulation 1928.57.
- The most important safety device on this equipment is a **SAFE** operator. It is the operator's responsibility to read and understand ALL Safety and Operating instructions in the manual and to follow these. All accidents can be avoided.
- A person who has not read and understood all operating and after instructions is not qualified to operate the machine. An untrained operator exposes themselves and bystanders to possible serious injury or death.
- Do not modify the equipment in any way. Unauthorized modification may impair the function and/or safety and could affect the life of the equipment.
- Think **SAFETY!** Work **SAFETY!**

2.1 GENERAL SAFETY

1. Read and understand the Operator's Manual and all safety signs and safety labels before operating, maintaining, and adjusting.
2. Provide a first-aid kit for use in case of an accident. Store in a highly visible place.
3. Provide a fire extinguisher for use in case of an accident. Store in a highly visible place.
4. Wear appropriate protective gear. This list includes but is not limited to:
 - A hard hat
 - Protective shoes with slip resistant soles
 - Protective glasses or goggles
 - Heavy gloves
 - Wet weather gear
 - Hearing protection
 - Proper Breathing Apparatus (during chemical spraying and dusting)
5. Do not operate without shields and guards in place.
6. Do not allow riders.
7. **Wear appropriate ear protection for prolonged exposure to excessive noise.**
8. Stop engine, set park brake, remove ignition key and wait for all moving parts to stop before attempting to service or adjust.
9. Clear the area of people, especially small children, before starting the unit.
10. Review all safety related items annually with all personnel who will be operating or maintaining this Buffalo Turbine unit.

2.2 OPERATING SAFETY

1. Read and understand the Operator's Manual and all safety signs before operating, servicing or adjusting.
2. Do not allow riders.
3. Install and secure all guards and shields before starting or operating.
4. Keep hands, feet, hair and clothing away from moving parts.
5. Set the Unit on level ground, stop engine, set park brake, remove ignition key and wait for all moving parts to stop before attempting to service, repair or adjust.
 - a) Before servicing or repairing the Models CS and CSM2, **Turn Off Engine and Disconnect Battery Terminals !**
6. Clear the area of all bystanders, especially children, before starting.
7. Wear appropriate hearing protection when operating the machine.
8. Do not allow people, pets or other animals to come within 200 feet of the outlet air stream.
9. Wear eye and ear protection.

2.3 MAINTENANCE SAFETY

1. Follow ALL operating, maintenance and safety information in the manual.
2. Support the machine with blocks or safety stands when changing tires or working beneath it.
3. Do not adjust any of the belts when the unit is running and engaged.
4. Make sure all guards are in place and properly secured when operating or maintaining the Sprayer.
5. Never wear ill-fitting, baggy or frayed clothing when working around or on any of the drive system components.

2.4 TRANSPORT SAFETY

1. Make sure you comply with all local regulations regarding transporting equipment on public roads and highways.
2. Ensure that the **SMV** (Slow Moving EMBLEM) and all reflectors and lights required by the local highway and transport authorities are in place and are clean and visible by overtaking and oncoming traffic.
3. **Do not allow any riders! (except when seat is provided)**
4. The rectangular tubing at the base of the sprayer unit must be used to load and unload the Sprayer unit onto a vehicle. Use caution when directing the lift forks into the rectangular tubing due to the 50 gallon stainless steel tank location. DO NOT OVERLOAD LIFT TRUCK.

2.5 STORAGE SAFETY

1. Store the Sprayer (or optional duster) on a firm, level surface.
2. Store away from areas of human activity. Do not permit children to play on or around the stored machine.
3. Make sure the unit is sitting, or blocked up firm and solid and will not tip or sink into a soft area.
4. Cover with a weatherproof tarpaulin and tie down securely.

2.6 TIRE SAFETY (Trailer Models)

1. Failure to follow proper procedures when mounting a tire on a wheel or rim can produce an explosion, which may result in serious injury or death.
2. Do not attempt to mount a tire unless you have the proper equipment and experience to do the job.
3. Have a qualified tire dealer or repair service perform required tire maintenance.

2.7 SAFETY DECALS

Keep safety decals and signs clean and legible at all times.

1. Replace safety decals and signs that are missing or have become illegible.
2. Replaced parts that displayed a safety sign should also display the current sign.
3. Safety decals or signs are available from your Dealer Parts Department.

How to Install Safety Decals:

- Be sure that the installation area is clean and dry.
- Decide on the exact position before you remove the backing paper.
- Remove the smallest portion of the split backing paper.
- Align the decal over the specified area and carefully press the small portion with the exposed sticky backing in place.
- Slowly peel back the remaining paper and carefully smooth the remaining portion of the decal in place.
- Small air pockets can be pierced with a pin and smoothed out using the piece of decal backing paper.

3. SAFETY DECAL LOCATIONS

The types of decal's on the blower units are shown below. For locations of each label, see parts reference in back of this manual.

Good safety requires that you familiarize yourself with the various Safety Decal's, the type of warning and the area, or particular function related to that area that requires your **SAFETY AWARENESS**.

• **Think SAFETY! Work SAFETY!**

! ATTENTION !

- 1. KEEP HANDS, FEET AND CLOTHING AWAY FROM POWER DRIVEN PARTS.**
- 2. STOP ENGINE BEFORE LEAVING OPERATOR'S POSITION.**
- 3. MACHINE HAS TO BE COMPLETELY STOPPED BEFORE STARTING TO ADJUST OR LUBRICATE.**
- 4. KEEP PEOPLE AND PETS AT SAFE DISTANCE FROM MACHINE.**
- 5. KEEP ALL GUARDS AND SHIELDS IN PLACE.**



NOTE: All decals are at 50% of actual size

REMEMBER - If Safety Decal's have been damaged, removed, become illegible or parts replaced without decal's, new decal's must be applied. New decal's are available from your authorized dealer.

4. OPERATIONS

OPERATING SAFETY

1. Review the Operator's manual before operating.
2. Keep all guards and shields in place.
3. Do not allow riders.
4. Clear the area of people, pets and other animals before starting.
5. Ensure that lights and reflectors are clean and working and comply with the regulations of transport authorities.
6. Review safety instructions with all operators annually.

4.1 TO THE NEW OPERATOR OR OWNER

Buffalo Turbine Sprayers and optional dusters are designed to quickly and efficiently apply concentrated sprays and/or dust, giving a thorough and wide-ranged coverage never before possible. Being adjustable allows a desired degree of agitation to the foliage, with enough velocity to completely carry through the tops of trees as well as through row after row of heavy thick leaf cover in row crops.

Many of the features incorporated into the machine are the result of suggestions made by customers like you. Read the manual carefully to learn to operate the machine safely and how to set it to provide maximum efficiency. The manual will take you step-by-step through your working day. By following the operating instructions in conjunction with a good maintenance program, your Buffalo Turbine Unit will provide many years of trouble-free service.

4.2 BREAK-IN

Although there are no operational restrictions on the Sprayer or optional Duster when it is used for the first time, it is recommended that the following mechanical items be checked:

- A. Operating for first ½ hour
 1. Retorque all wheel bolts and axle nuts. (Trailer Models)
 2. Re-torque all other fasteners and hardware.
- B. Operating for first 5 hours
 1. Retorque all hardware and fasteners.
 2. Check the drive belt tension. Adjust as required.
 3. Go to the normal servicing and maintenance schedule as defined in the Maintenance Section.

4.3 PRE-OPERATION CHECKLIST

Efficient and safe operation of the Buffalo Turbine Sprayers and Dusters require that each operator reads and understands the operating procedures and all related safety precautions outlined in this section. A pre-operation checklist is provided for the operator. It is important for both personal safety and maintaining the good mechanical condition of the machine that this checklist is followed.

Model CSM2

Before operating the Sprayer and each time thereafter, the following areas should be checked off:

1. Lubricate the machine per the schedule outlined in the maintenance section.
2. Prime the Hypro pump especially when the liquid tank was drained and cleaned.
3. Use an appropriate vehicle designed to handle this type of equipment.
4. Ensure that the machine is properly attached and anchored to the vehicle.
5. Make sure all guards and shields are in place, secured and functioning as designed.
6. Check the belts and pulleys for proper tension and alignment.
7. Ensure all bearings turn freely.

4.4 REPAIR PARTS

Use Buffalo Turbine repair parts only to ensure safe and efficient operation of the sprayers and dusters. Warranty will be void if substitute replacement parts are used.

MODELS CSM2

Before Operating the Sprayer (optional duster) and each time thereafter, the following areas should be checked off.

1. For fuel, oil, and operating information of the Kohler Engine, refer to the manufacturers specs included with this manual.
2. The trailer models must have proper tires, warning signs and lights when on public highways and roads. Check your local Motor Vehicle Dept. or law enforcement for restrictions. **Maximum speed is 45mph!**
3. Insure the Trailer Unit and Towing Vehicle have the proper receiver and coupler.
4. Make sure all guards and shields are in place, secured and functioning as designed.
5. Always use eye and hearing safety protection when operating this or any other equipment.

4.6 FIELD OPERATION

OPERATION SAFETY

1. Review the Operator's manual before starting.
2. Do not allow riders unless seat is provided.
3. Keep all guards in place when operating equipment.
4. Stop engine, set park brake, remove ignition key and wait for all moving parts to stop before dismounting to service, adjust or repair.
5. Do not direct air stream towards people, pets or other animals or in congested areas.

4.7 Operating RPM (Both Models)

The Models CSM2 may be run at maximum RPM or wide-open throttle. This recommendation is made to insure maximum coverage necessary. The Sprayer (optional duster) can operate at a slower RPM if shorter distance or less coverage is required.

When operating the machine, follow these procedures:

1. Start and operate the Sprayer/Duster according to owner's manual.
2. Make sure Sprayer (optional duster) accessories are disengaged before starting.
3. Clear the area of bystanders before starting.
4. Model CSM2 are equipped with an electric remote nozzle, liquid, dust bin and throttle cab control box: (12v system)
 - a. Pressing the toggle switch marked "NOZZLE" on the hand held cab control box changes the air stream direction. The nozzle will stop turning by releasing the toggle switch (momentary switch). Use caution and always check clearances around nozzle rotation. (360-degree rotation).
 - b. The toggle switch marked "LIQUID" turns the pump on and off. Flow rate has to be adjusted at the pressure relief valve. Have the nozzle in position before turning pump on. The nozzle tips have a .036 orifice opening (6502). A variety of sizes are available.
 - c. The momentary toggle switch marked "THROTTLE" will raise and lower the RPM of the Kohler engine. Pressing or releasing the toggle switch in either direction will either raise or lower the engine's RPM. Adjustment is from an idle to maximum RPM.

- d. OPTION: The momentary toggle switch marked "DUST BIN GATE" will open and close the dust feed gates and will adjust for variable feed rates of chemical dust into the air stream.
- e. OPTION: The toggle switch marked "DUST BIN" will engage the clutch of the dustbin. The dust feed shafts and the dust agitators will be turning when the toggle switch is in the on position.



Cab control box

ALL LIQUID AND DRY CHEMICAL MIXTURES HAVE SPECIFIC COVERAGE RATINGS. GROUND TRAVEL SPEED, ENGINE RPM OF THE MODEL CS II, WIND SPEED AND ACREAGE TO BE COVERED, HAS TO BE CALCULATED AND MANUALLY MEASURED FOR PROPER COVERAGE. Dustbin opening and / or nozzle tip orifice size will greatly affect coverage.

NOTE: Make sure the remote cable is clear of all moving parts.

corners of the frame ONLY.

4.8 TRANSPORTING (trailer pkg.)



TRANSPORT SAFETY

1. Clean lights, reflectors and SMV before transporting on a public road or highway.
2. Insure that unit complies with all regulations by the local transport authorities for lights and reflectors and SAFETY equipment.
3. Do not allow riders on roads or highways, even if seat is provided.
4. Travel at a safe speed. Slow down for corners, rough roads or rough terrain.

Buffalo Turbine Models CSM2 can easily be transported and conveniently moved from place-to-place. To prepare for transport, follow this procedure:

1. Be sure all bystanders are clear.
2. Ensure unit is properly connected to the towing vehicle.
3. Be sure that all tires, lights, reflectors and SAFETY equipment required by the local highway and transport authorities are in place and are clean and visible by overtaking and oncoming traffic.
4. It is not recommended that the machine be transported faster than 45 mph (70km/h). Slow down for corners or rough roads and terrain. Always retain control of the vehicle.

4.9 Transporting the Model CSM2

1. **Trailer Receptacle** (trailer pkg only)
Recommendation: Class II (minimum capacity 3500 lbs). Do Not Exceed 45MPH At Any Time.
2. The Model CSM2 with the trailer package may be transported on a flat bed truck. Be sure to block the wheels and fasten securely. **NEVER ANCHOR THE SPRAYER OVER THE TOP OF THE TURBINE**
3. **When mounting the unit on a flat bed or pick up truck, securely STOP and CLAMP in the 4**

4.10 STORAGE

Daily cleaning is recommended especially if corrosive materials are being used.

At the end of the working season or storing the unit for a period of time, prepare the machine by following this procedure:

1. Select a storage area that is dry, level and free of debris.
2. Thoroughly wash the machine, including the tank, with a water hose to remove all debris and residue.
3. Lubricate all grease fittings with one shot of grease to displace any accumulated water.
4. Run the machine at low RPM to dry the Blower Components
5. Touch up all paint chips and scratches to prevent rusting.
6. Inspect for worn or failed components. Order the replacement parts now and repair when the time allows, eliminating unnecessary down time at the start of next season.
7. Store in an enclosed building. If space is not available, cover with a waterproof tarpaulin and tie it down securely.
8. Store the machine away from the areas of human activity.
9. Do not allow children to play around the stored unit.

Model CSM2

Wash the Blower unit, then run at lower rpm's to dry blower and engine. Change oil per manufacturer's specs. Spray a lubricant on the nozzle base to ensure smooth operation and the prevention of rust. Park and block unit so the tires clear the ground.

5. SERVICE AND MAINTENANCE



MAINTENANCE SAFETY

1. Set the unit on a level surface, stop engine, set park brake, remove ignition key and wait for all moving parts to stop before attempting to service, adjust or repair.
2. Reinstall and secure all shields removed for servicing before starting to use machine again.
3. Securely support machine with blocks or safety stands when changing tires or working beneath it.

5.1.2 GREASING

Refer to Section 5.1.1 for recommended grease. Use the Maintenance Checklist provided to keep a record of all scheduled maintenance.

1. Use only a hand-held grease gun for all greasing. Air powered greasing systems can damage the seals on bearings and lead to early bearing failure.

IMPORTANT

Over-greasing can damage bearing seals. A damaged seal will lead to early bearing failure. Replace all damaged bearings with factory ordered parts.

2. Replace and repair broken fittings immediately.
3. If a fitting will not take grease, remove and clean thoroughly. Also clean lubricant passageway. Replace fitting if necessary.

5.1 Service

5.1.1 FLUIDS AND LUBRICANTS

1. Grease (Models CSM2)

Use SAE multi-purpose high temperature grease for all applications. SAE multi- purpose lithium base grease is also acceptable. A Teflon spray type lubricant on the nozzle base and nylon slides provide for freer rotation.

USE ONLY CLEAN LUBRICANTS

2. **Model CSM2:** Change oil per Manufacturer's specs (provided with manual).

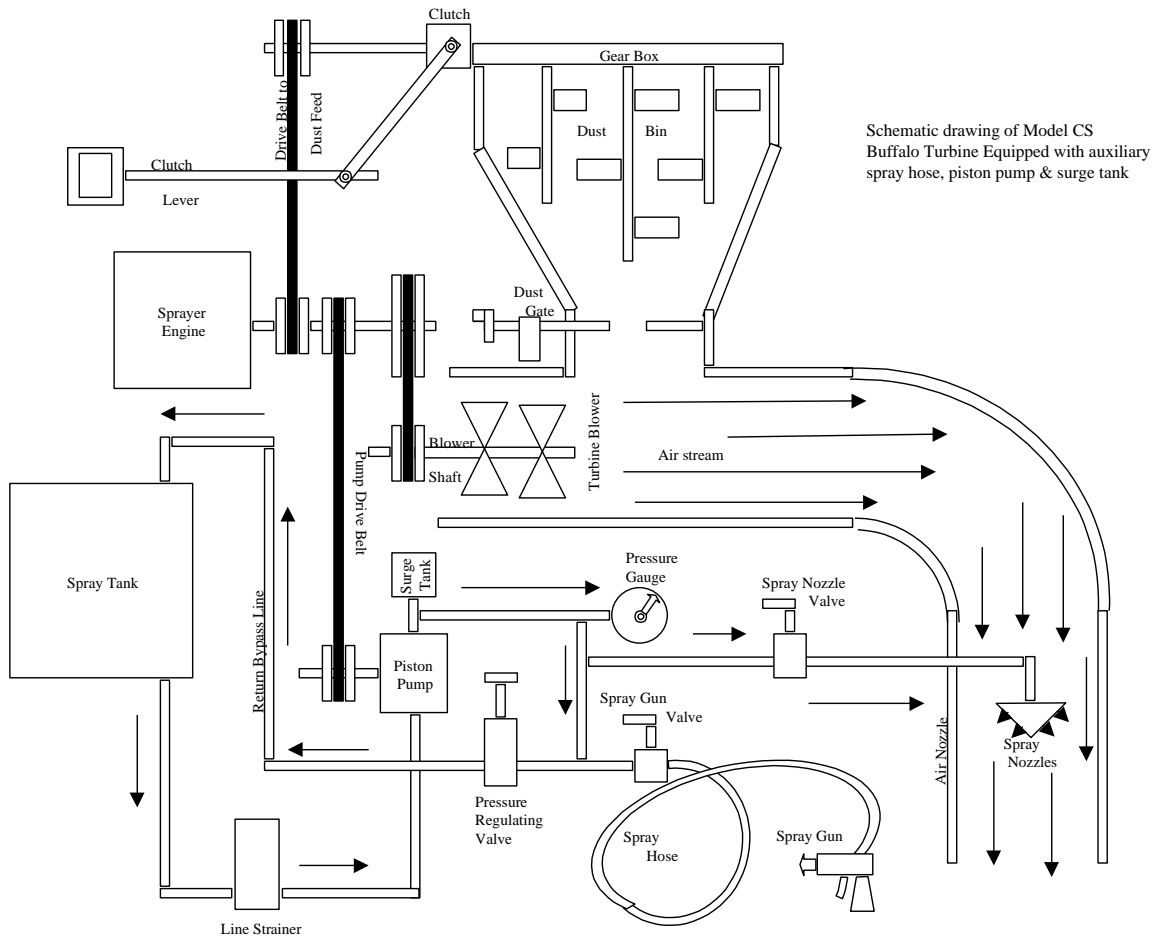

Model CSM2 plumbing set up

This schematic is only a guide.

This schematic reflects the early designed Model CSM with dustbin only

5.1.4 SERVICE RECORD

See Lubrication and Maintenance sections for details of service. Copy this page to continue record.
See separate insert for optional dustbin maintenance.

CODE: LUBRICATE (L) / CHECK- (*) / CHANGE-(C) / REPLACE- (B) / CLEAN- (CL)

SCHEDULED MAINTENANCE HOURS

SERVICED BY

MAINTENANCE

8 hrs or daily

(*) Engine Oil- Follow Manufacturers Specs

(CL) Liquid Tank, nozzle tips and screens, strainer, Optional Dust Bin

40 hours

(L) Bearing, End

(L) Pillow block bearings - greasing

(L) Nozzle base and nylon slides (spray, i.e. Teflon)

(*) Belt tension- SEE SECTION 5.2.1.

80 hours

(CL) General Filter Cartridge - nozzle tip screens or as needed

(CL) External engine fuel filter - see engine manual

100 hours

(L) Pump Grease Fitting on cam bearing – Use Moly Lithium or equivalent grease. With a flat tool, apply a generous dab of grease to the outer diameter surface of the cam bearing at the top and bottom, where the bearing contacts the connecting rod. (see HYPRO pump insert)

(L) Dust Bin—see form PB-10-10-77 in the back of this manual

(CL) Turbine Blades and Vanes

200hrs or annually

(CL) Machine—Clean Turbine blades and vanes - keep turbine free of debris and grime

(L) Grease and lubricate all fittings including nozzle base.

(L) Wheel Bearings (trailer model)

5.2 Maintenance

5.2.1 Belt Tension

Efficient machine operation requires that the belts always be properly tensioned.

V -belts B32 and B43 are used to drive the pump (shown below).

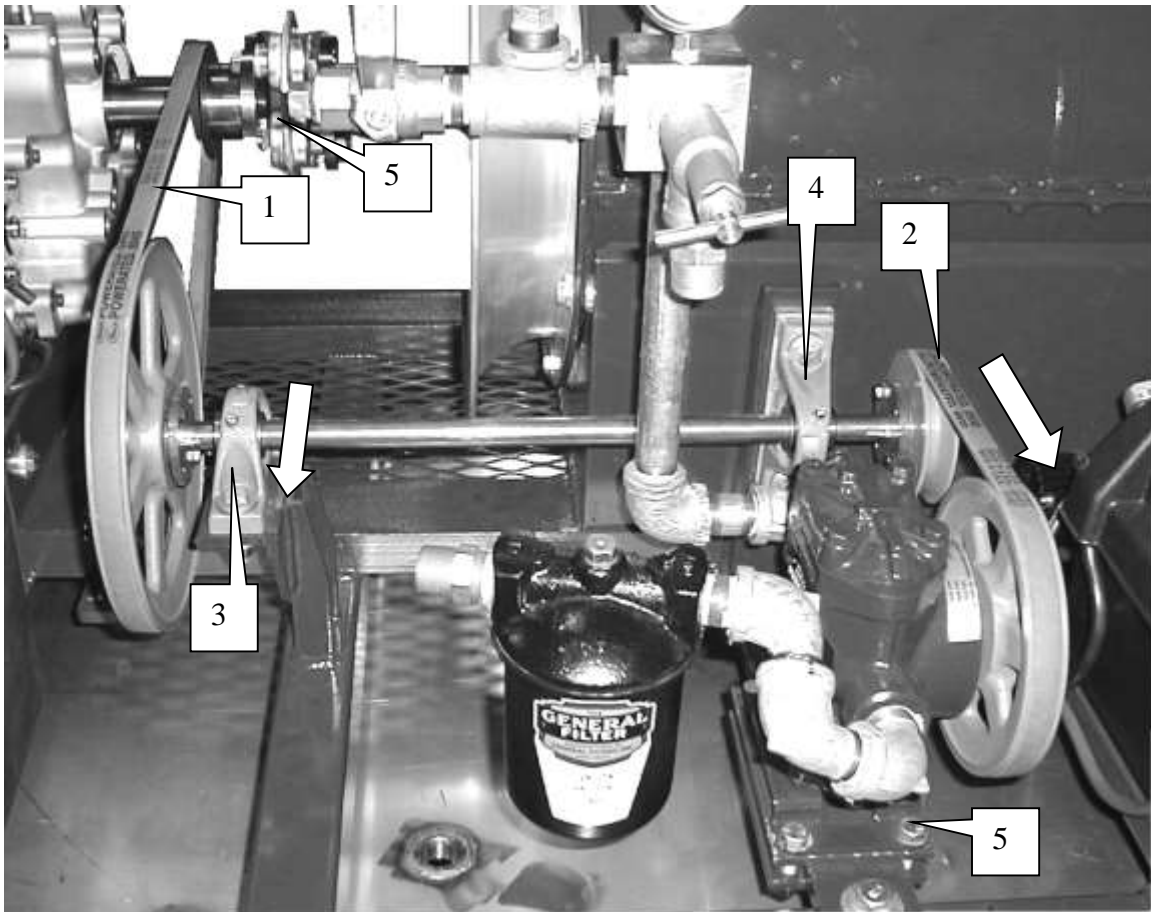

To adjust belt #1 (B43), loosen bolts on bearing #3 then move bearing in the direction of the arrow. Tighten bolts securely and check for proper tension.

To adjust belt #2 (B35), loosen pump mounting bolts at the base of the pump and move in the direction of the arrow. Tighten bolts securely and check for proper tension.

Always check the pulleys and jack shaft alignment after any adjustments are made.

Replace belts that are broken, worn or stretched.

5.3 Changing the Belts

After using the Model CSM2 for a long period of time, the belts will stretch and wear. To change belts, follow this procedure:

1. Turn off engine and remove key for **SAFETY**. Remove the guards around belt and pulleys.
2. Refer to the picture section 4.2.1 for changing the belts.
To replace belt #1 (B43), loosen bearing #3 then slide the bearing toward the out put shaft of the engine.
The center section of the coupling (#5) will have to be removed in order to remove the old belt and install a new one. Page 28 has a detailed picture of the coupling.
The center section of the coupling must be disassembled and assembled with extreme care. Damage to the coupling can result in premature bearing failure in the turbine and engine. A new bolt kit for the coupling is recommended before reassembling the coupling. **ALWAYS USE TOPLOC NUTS.** Remove the bolts from the coupling (2 ea. side of flange). Loosen setscrews on one flange only. A thread lock material is used on the threads at assembly. Heat may be needed to break that bond. Clean all dirt and rust that has accumulated on the shaft (behind the flange) then slowly wedge the center section off of the flange. Note: The flanges are counter bored to match the flange bushings. Once the center section is removed, belt #1 can be removed and a new belt can be installed. **DO NOT TENSION THE BELT UNTIL THE CENTER SECTION OF THE COUPLING IS INSTALLED.**
Bolt the center section per the picture on page 28. **DO NOT TIGHTEN THE SET SCREWS AT THIS TIME.** Note position of bolts and locking nuts. Once the coupling is installed and securely tightened, check to see if the key is in position on the shaft and in the keyway of the flange. Coat the setscrews with Loc Tite (red) and securely tighten. Re check all the setscrews and coupling bolts before proceeding.

3. To replace belt #2 (B32), loosen mounting bolts (#5) under the pump and slide toward the Turbine. Remove old belt then install the new belt. Adjust the belt tension by sliding the pump assembly away from the Turbine Assembly. See section 4.2.1. in the previous section for more information. Check the pulley alignment and recheck both belts and the tightness of all bolts and set screws. **ASSEMBLE ALL GUARDS BEFORE OPERATING UNIT!**
4. To replace (4L870) dustbin belts (optional dust bin models only) remove dustbin cover. Remove two 3/8" bolts on jackshaft right side bearing. Slide old belts off. Replace with new belts and reinstall two 3/8" bolts in pillow block, apply pressure straight down on jackshaft to give proper belt tension and tighten pillow block bolts. Reinstall guards.

5. Install all guards before operating blower unit!

6 TROUBLE SHOOTING

The Buffalo Turbine Model CSM2 uses a high volume and velocity of air to apply concentrated sprays and or dust. It is a simple and reliable system that requires minimal maintenance.

In the following section, we have listed many of the problems, causes and solutions to the problems that you may encounter.

If you encounter a problem that is difficult to solve, even after reading through this trouble shooting section, please call Buffalo Turbine, your local dealer or distributor. **Before you call, please have the Operator's Manual and the serial number from your Model CSM2 ready.**

PROBLEM	CAUSE	SOLUTION
Blower does not turn	Engine not running Engine running Sheared key	Start Engine Replace broken belt Replace key on sheave
Engine will not start	Dead battery Battery cables dirty or disconnected Fuel valve shut off	Charge or replace battery Clean and connect terminals Turn on fuel valve
No liquid spray	Toggle switch not turned on Holding tank plugged or empty Loose or broken belt Pulleys slipping Defective solenoid Defective or worn pump Dirty cartridge filter or nozzle screens	Turn switch on from control panel Check hoses and fill tank Adjust or replace belts Tighten set screws on pulleys Replace solenoid Rebuild or replace pump Clean or replace mesh filters
Dust Bin troubles	Clutch not engaged Dust packing solid Loose or broken belts Pulleys slipping Inconsistent application	Turn switch on from control panel See form PB-82/check agitators Adjust or replace belts Tighten set screws on pulleys Check and clean control gates
Belts or pulleys overheat	Belts slipping	Adjust belt tension
No air flow	Blower fan not turning Blower fan turns Air intake or exhaust restricted	See solutions above Turn off engine and remove any debris restrictions
Machine vibrates	Bearing failure Out-of-balance	Replace bearings Check for damaged blades or vanes in the blower unit

7 SPECIFICATION

Model CSM2

Length: (without trailer)	69" with nozzle assembly
Length: (with trailer)	103
Width: (without trailer)	37"
Width: (with trailer)	71"
Height: (without trailer)	42"
Height: (with trailer)	62" (with Dust Bin 80")
Weight: (without trailer)	725lbs.
Weight: (with trailer)	1100lbs.
Weight: (with Dust Bin only)	N/A
Weight: (with Dust Bin and Trailer Pkg.)	1400 lbs
Fuel Capacity:	6 Gallons
Electrical System:	12V Battery (negative ground)
Input Power:	25hp Kohler Command PRO
Input RPM:	3600 RPM
Outlet Size:	12"
12 volt Control Valve	150 PSI (maximum)

MODEL CSM2G PARTS LIST

(Trailer parts listed separately)

Ref. Page#	Qty.	Description	Part #
26	2	Nut, ½ - 13	1231
26	4	½ Lockwasher	1222
26	1	Actuator Mounting Pin Bracket	1451
26,29	2	Cotter Pin, 3/16 x 1 ½	1194
26	1	Actuator, 4"	1409
26,29	20	Nyloc Nut, ¼ - 20	1125
26	2	Cotter Pin, 1/16 x ½	1193
26,29	2	Throttle Lever Pin	1414
26	1	Fuel Tank, 6 gallon EPA/CARB approved	3316
26	1	EPA Cap, Fuel Tank	3314
26	2	Straps, Fuel Tank	1788
28	1	Sight Glass, Brass (SS Tank)	1595
28	1	Tank, 50 gallon SS	5279
27	3	Drain Plug, Tank	1536
28	1	2" NPT GALVANIZED 90 DEGREE STREET ELBOW	3830
28	1	2" NPT GALVANIZED NIPPLE, 5" LG	3831
28	1	Filler Tube Cap, 2" galvanized (SS Tank)	1532
26	1	Transition Guard Sprayer	5320
26	1	Pump Guard	5311
26	1	Battery Box with Cover	1378R
	1	12 volt Battery, min. 300 CCA	1132
26	1	VERTICAL BELT GUARD, DUSTER	5326
26	1	Drive Guard	3733
27	1	Strainer Housing	4154
27	43	Hose ¾"	1732
27	1	Pressure Relief Valve, 3/4	1521
27	1	Manifold Block, Aluminum	1487
27	1	Pressure Gage, 0-300 lbs.	1523
27	1	Solenoid Valve, 12v	1524
28	1	Pulley 3.38 x 1.48, Engine	1586
28	1	Morflex Coupling Complete, Kohler Sprayer	1746
	1	Coupling, Center Section	1256
	4ea.	Coupling, Bolt Kit – (4) 7/16-20x2 ½ HHCS Zinc and (4) 7/16-20 Top loc nuts	1113,1112
	1	Coupling, Flange 1 ¼	1114
	1	Coupling, Flange 1 7/16	1115
	2	Coupling, Key ¼ x 2	1110
28	1	Coupling, Key 3/8	3805
	1	Coupling Set Screws	2869
27	2	Pillow Block Bearing, 3/4	1247
27	1	Jack Shaft, Duster	2222
27	1	Belt, Engine to Jackshaft	5290
27	1	Sheave, BK 100H	1555
27	1	Pump	5297
27	1	Belt, Jackshaft to Pump	5289
27	1	Sheave, BK 90H	3803
27	1	Bushing, H 1	1648

27	1	Sheave, BK 40H	1562
27	2	Bushing, H ¾	1563
27	2	AK25 X ¾ Sheave for Duster	1135
27	2	A-81 V-Belt for Duster	1291
28	1	Engine, CH740 Kohler	3073
28	1	Frame with Cradle	4353
28	2	Rail, Engine	1359
28	3	Slides, Rotation	1138
28	1	Elbow Base, Short	1141
28	1	Belt, Rotation	1142
28	2	Quick Release Clamp Band	4935
28	1	Clamp Band	1173
28	2	Elbow Segment	1171
28	1	Rotation Motor	1143
28	1	Motor Bracket (Rotation Motor)	1144
28	1	Sheave, AK 32 x ½	1145
28	1	Pump Guide Weldment	5292
28	1	Pump Mount Weldment	5294
28	1	Round Nozzle Assy, Sprayer	1999
	1	Nipple, Brass Hex, ½	1594
	1	1/2" PIPE COUPLING, GALVINIZED	3331
29	1	Dust Feed Channel Cover	1987
29	1	RH Blower Assembly	5401
29	1	Granular Bin Sub Assembly	4201
29	1	DUST BIN FOR DUSTER SPRAYER	1982
29	1	LATCH AND CATCH, DUSTER	1767
29	1	HANDLE FOR DUSTER BIN	2224
29	1	DUST BIN GAGE BAR	2212
29	1	ACTUATOR MOUNT, DUSTER	2223
29	1	GAGE BAR POINTER, DUSTER	2213
29	1	DUST BIN MOUNT, FRONT	1983
29	1	Slide Actuator, 2"	1542
29	1	GATE CONNECTING BAR, DUSTER	2220
28	1	Bellmouth	1119
29	1	DUST BIN MOUNT, REAR	1984
29	3	DUST FEED BUSHING, BRONZE	2218
29	4	5/8" SHAFT COLLAR, DUSTER	1568
29	3	DUST FEED SHAFT, VERTICAL	1696
29	9	DUST AGITATOR	1464
29	3	DUST FEED AUGER	1896
29	3	SPACER, VERTICAL DUSTER SHAFT	2219
29	3	DUST FEED GATE FLANGE, CASTING	2211
29	3	DUST FEED GATE, STAINLESS	2210
29	3	DUST FEED STUD, VERTICAL	1519
29	3	DUST FEED CONE	1922
29	2	DUST FEED WIRE SCREW, LONG	1356
29	2	DUST FEED TUBE LONG	1851
29	1	DUST FEED TUBE SHORT	1852
29	3	5/8" PILLOW BLOCK BEARING	1577
29	3	GEAR BLANK FOR DUSTBIN GEAR	1578
29	3	WORM TO FIT 1578	1579
29	1	DOUBLE CLUTCH PULLEY	2216
29	1	DUST FEED CHANNEL, DUSTER	1986
29	1	WARNER ELECTRIC CLUTCH, SF400-5/8-12V	2214
29	1	Dust Feed Shaft, Horizontal	1644
29	1	Short Dust Feed Wire	5337
29	15	¼-20 x ¾" Long Set Screw	2228

27	1	Ball Valve Seal Cap	1244
28	1	Tank Retainer	1728
27	1	¾" Tee, Galvanized	1534
27	1	Valve, Brass Ball, ¾	1525
27	2	Nipple, Brass Hex, ¾	1593
27	3	¾" female couplamatic hose end	1560
27	1	Aluminum Spacer 3/8 x 1-1/2 x 5.1	1597
27	6	Hose clamp	3514
27	1	Pump Adapter	5287
27	1	Pump Extension Adapter	5288
	1	Control Box Assembly 5 switch	1835
	3	Toggle Switches, Momentary (Nozzle & Throttle)	1277
	2	Toggle Switch, On/Off (Solenoid)	1485
	1	Manifold, Nozzle (4 Stations)	1480
	4	Nozzle Body, Brass, ¼ TT (SSCCP1322)	1652
	4	Nozzle Tips, Brass, .035 (SSCTP6502)	1649
	4	Cap, Nozzle Body, Brass, 1/4 NPT (SSCCP1325)	1653
	4	Strainer, Aluminum w/SS Screen (SSC5053-50-SS)	1651
	3	Support Arms, Nozzle Manifold	1307
	6	Jam Nut 1/4 SS, Support Arm	1724
	6	Flat Washer, Support Arm	1725
	4	Nozzle Tips, Brass, .043 (SSCTP6503)	1650
	3	4 x 4 BT Decal	1182
	1	Thrown object, Eye & Ear protection Decal	4725
	1	Caution Do Not Operate Decal	1186
	1	8 x 10 BT Decal	1187
	4	¼-20 x 2-¾" HHCS	3802
	1	½" x 1-1/2" Galvanized Nipple	3399
	1	3/8-24 x 1-1/2 Faced Head Bolt	3521
	1	Bolt, ½ Pushover	1218
	1	Pump pushover bolt	1727
46		Fuel hose	1158
	4	Spacer- 3/8 x 3/16 Thick washer	1106
	4	Notched Washer	1139
	1	Hour Meter	1372
	6	10-32 x 5/8 SHCS	1146
	2	1 x ½ x 3/16 Thick Washer	1223
	3	3/16 x 1 Roll Pin	1236
	4	Nut Plate, 3/8"	1499
	6	¾" Street Ell, Galvanized	1528
	1	¾" x 2" Galvanized Nipple	1529
	2	3/16 Square x 1-3/8 Key	1596
60		½" Goodyear Ortac Hose	1720
	1	½" Male Vari Crimp Coupling	2395
	2	Galv. Reducing Bushing, ¾ to ½	1530

**BT-CSM2G PARTS REFERENCE
(BEGINNING W/ SERIAL #40641)**

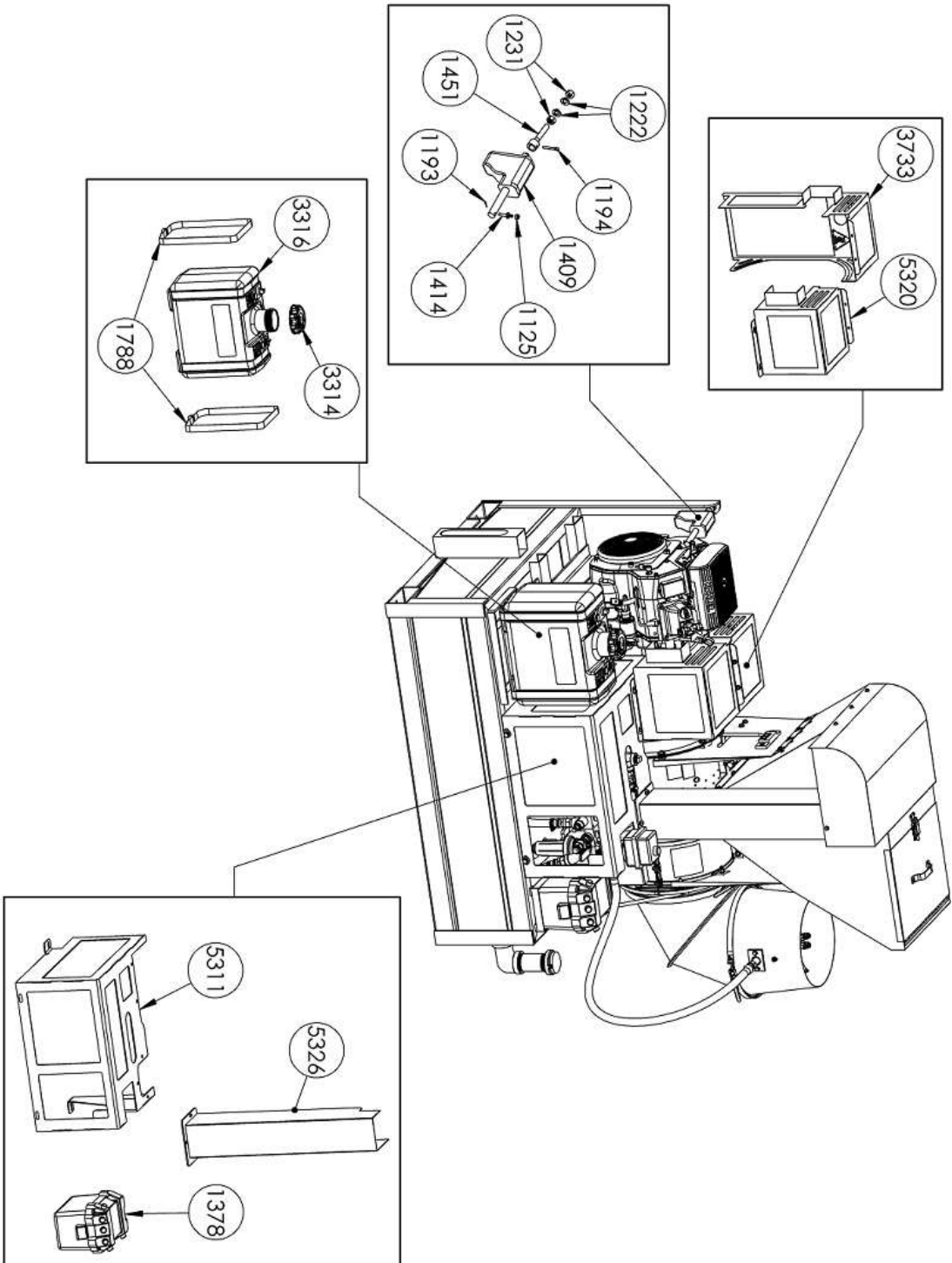

BT-CSM2G PARTS REFERENCE CONT. (BEGINNING W/ SERIAL #40641)

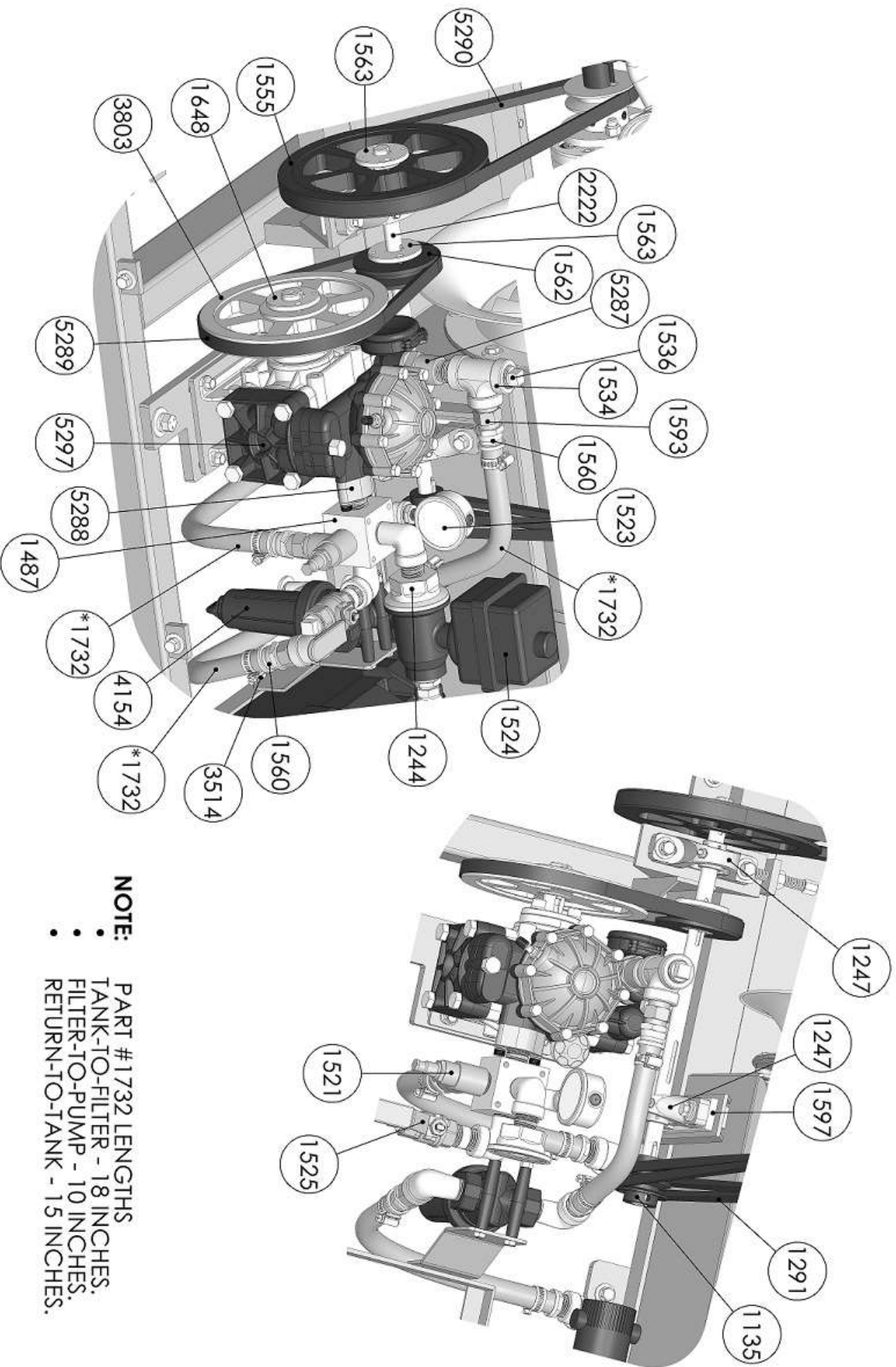

NOTE:

- PART #1732 LENGTHS
- TANK-TO-FILTER - 18 INCHES.
- FILTER-TO-PUMP - 10 INCHES.
- RETURN-TO-TANK - 15 INCHES.

BT-CSM2G PARTS REFERENCE CONT. (BEGINNING W/ SERIAL #40641)

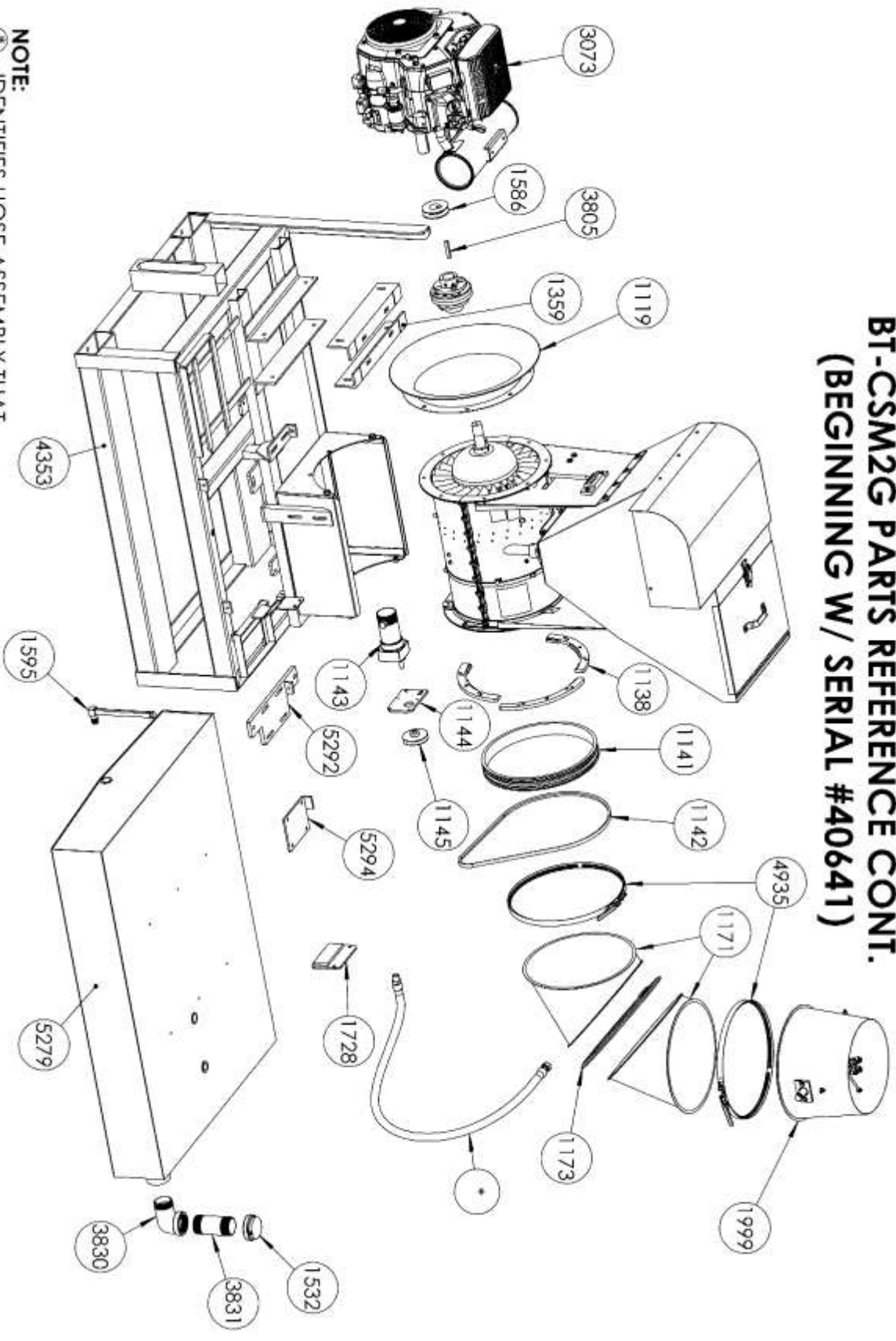

NOTE:
 - IDENTIFIES HOSE ASSEMBLY THAT
 CONSISTS OF PART #'S 1558, 1720, & 2395.

BT-CSM2G PARTS REFERENCE CONT. (BEGINNING W/ SERIAL #40641)

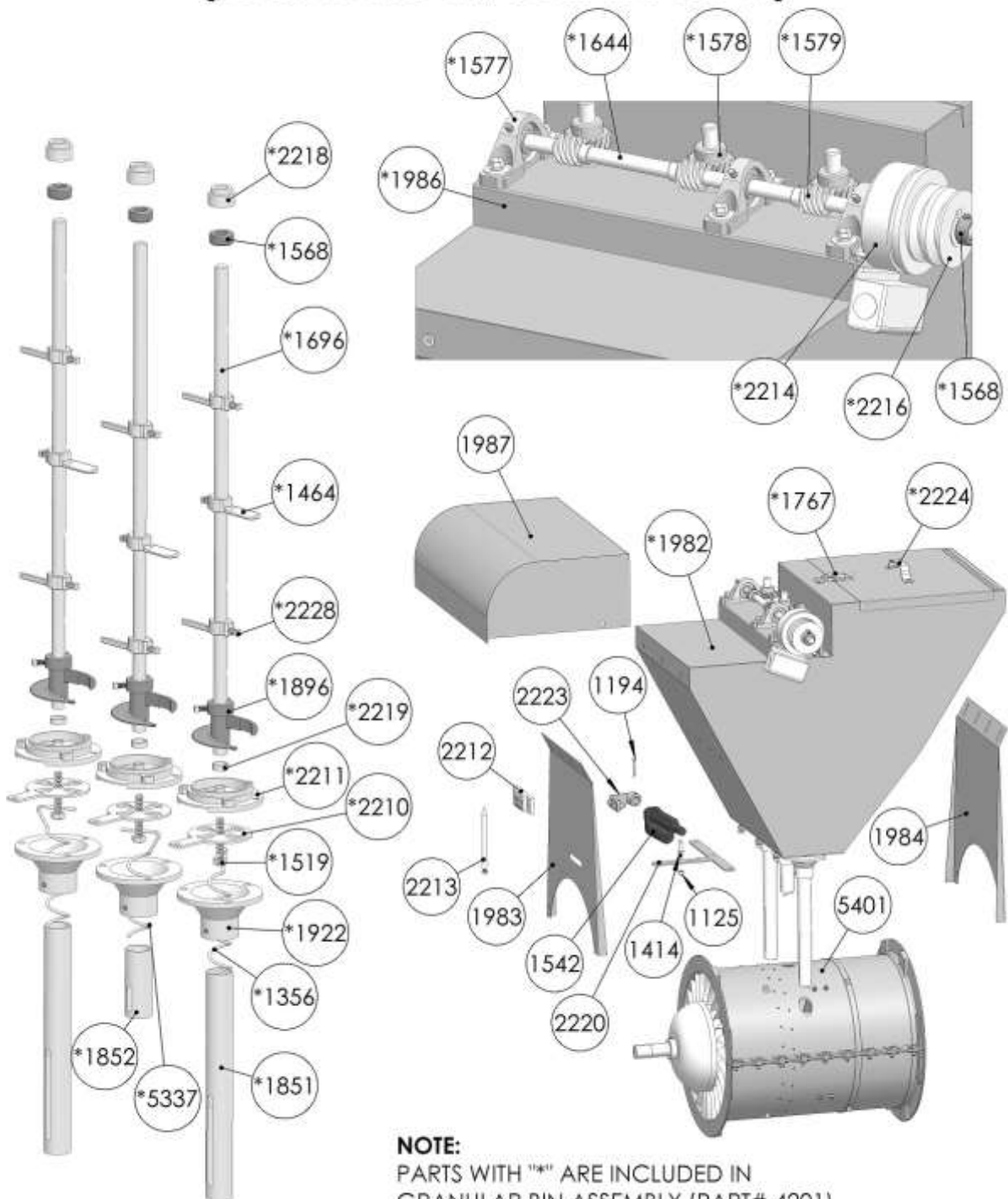

NOTE:
PARTS WITH "*" ARE INCLUDED IN
GRANULAR BIN ASSEMBLY (PART# 4201)

DUST BIN DIS – ASSEMBLY AND ASSEMBLY INSTRUCTIONS

1. Remove the (3) bolts on cover and remove cover.
2. Remove the (4) bolts and nuts on front and rear dustbin mounts.
3. Remove dustbin gate lever.
4. Remove belts from dust -bin clutch and lift dust- bin out of mounting.
5. After removing dust -bin from the sprayer, set dust- bin on a stand with dust- bin tubes pointing up.
6. Remove the (3) bolts on each dust –bin dust -cone assembly and lift off cones and tubes. Check tubes for wear and replace by loosening (2) setscrews in the neck of the cone. Make sure tube slots are at right angles of the air -flow when replaced.
7. Remove the dust twist springs by sliding side ways from holes on dust twist feed stud. Remove dust -twist feed studs and dust- gates.
8. The dust feed flange must remain in bottom of dust- bin. Use bolts to remove and bolt flange in place.
9. Turn dustbin bottom side down.
10. To remove dust clutch, loosen set -screw on collar next to clutch cam. Drive out spring pins and remove. Next remove ¼ x 1 Allen head screws from throw-out shaft and bronze shaft collar and remove shaft collar. Loosen set -screw on tandem plate cover and slide clutch from horizontal shaft. Check drive plates on clutch and replace as needed.
11. Loosen set-screws on pillow block bearings
12. Drive spring- pins from gears and shaft and remove gears. Check gears for wear and replace as needed.
13. Remove bolts from (2) end pillow block bearings and lift dust- bin channel from shafts. Check bronze bushings in channel and replace as needed.
14. Check vertical shafts for wear. Replace as needed.
15. Reverse procedures to re-assemble.
16. For lubrication, see general instructions for operation.

LUBRICATION

#1 - #2 - # - #4 - # 5 Dust Bin Lubrication
Use Grade NLGI #2 lithium grease.
Grease every 25 hours

#12 - #13 - #14 Dust Bin Gears
Open gear Hi-Low gear lubrication NLGI # 3
Grease every 25 hours

#7 - #8 - #9 Unit
Multi purpose grease
Grease every 25 hours

#15 Blower
Sealed bearing, no lubrication required

#16 Pump
Use Grade NLGI # 2 Lithium grease. See pump instruction sheet.

Engine oil. Refer to engine manual.

MODEL CSM2

Horizontal Range-Liquid and Dust	125 Feet *
Vertical Range-Liquid and Dust	75-100 Feet *
Flow Rate of Dust	½ lb. per min (30 lbs. Hr) Minimum * 5 lbs. per min (300 lbs. Hr) Maximum *
Flow Rate of Granular (Good Coverage 70-80 Feet)	3-1/3 lbs. per min Minimum * 40 lbs. per min Maximum *
Flow Rate of Liquid	varies depending on pressure setting, Size of nozzle tips(orifice opening) and number of nozzles being used. (See flow rate chart in the instruction manual)

*These are approximate figures only. Weather conditions, material concentration (powder, liquid and granular) condition of sprayer/duster unit will determine actual disbursement of materials.

USES:

Vector Control- Fly, Mosquito, etc.
Row Crops
Orchards
Grasshopper Control
Weed Control
Fertilizing
Soil Stabilization
Growth Retardant
Fly Control
Mosquito Control
Odor Control
Feed Lots
Disinfecting Buildings, Etc.
Golf Course Work
Shade and Ornamental Tree Work
Odor and Fly Control at Dump and Landfill Sites

SUPPLEMENT A

The Nozzle and pressure chart for application of liquids using the Buffalo Turbine Model CS and CSM2 Sprayer. Application of liquid using 4 nozzles.

<u>GALLONS PER MINUTE</u> (using 4 spray nozzles)	<u>NOZZLE #</u>	<u>PRESSURE (PSI)</u>
.2	650067 - .021(orifice)	20
.24	650067	30
.28	6501 - .026	20
.32	6501	25
.4	6501	40
.48	6501	60
.5	6501	65
.44	65015 - .031	20
.6	65015	40
.72	65015	60
.56	6502 - .036	20
.68	6502	30
.8	6502	40
1.0	6502	60
.84	6503 - .043	20
1.04	6503	30
1.2	6503	40
1.48	6503	60
1.4	6504 - .052	30
1.6	6504	40
2.0	6505 - .057	40
2.4	6506 - .062	40
3.2	6508 - .072	40
4.0	6510 - .078	40
6.0	6515 - .093	40
8.0	6520 - .109	40

Above information are approximate values only

Maximum recommended pressure – 150 PSI
Control Valve part # 1524

MAINTENANCE OF THE BUFFALO TURBINE SPRAYER/DUSTER

The proper care and operation of the Buffalo Turbine Sprayer/Duster will increase the likelihood of obtaining satisfactory control and will largely eliminate the frustration that results from malfunctioning of the machine when time is critical and the machine is most needed.

GENERAL INFORMATION

1. **NEVER** operate or start machine when pump is dry. You will overheat and seriously damage the pistons and seals by doing so. Make sure liquid is in the tank and the liquid line from tank to pump is open.
2. **NEVER** engage dust- bin clutch when dust gates are in a closed position.
3. When using dusts, granules, or pellets it is best to fill the dustbin after reaching the application area, as the jarring from traveling will pace some dust solid.

DAILY MAINTENANCE

1. Check inside of blower, tank, and dust -bin to insure that there are no foreign objects to interfere with moving parts.
2. Check belt tensions.
3. Check for loose nuts or bolts.
4. All lubrication points should be checked to see that they are lubricated. **DO NOT OVER GREASE.**
5. **NEVER LEAVE INSECTICIDE IN THE SPRAYER OVERNIGHT.** Some of the insecticides in use are highly corrosive and will cause damage to the sprayer if they remain in the lines, pump, etc., overnight. Spraying operations should continue until all the solution in the tank has been used. Then the tank should be partially filled with water and the liquid sprayed from the machine until clear water emerges from the nozzles. This flushing operation usually takes 10-15 minutes and **MUST** be carried out at the end of each day's spraying. While this flushing operation is being carried out, the hopper and blower should be washed.
6. The liquid line strainer (liquid filter) should be removed at the end of each day and the screen cleaned before replacing and tightening the tip. Failure to carry out this procedure may result in plugging up the lines completely or inconsistent spray output.