

## PTO DUST/ODOR CONTROLLER

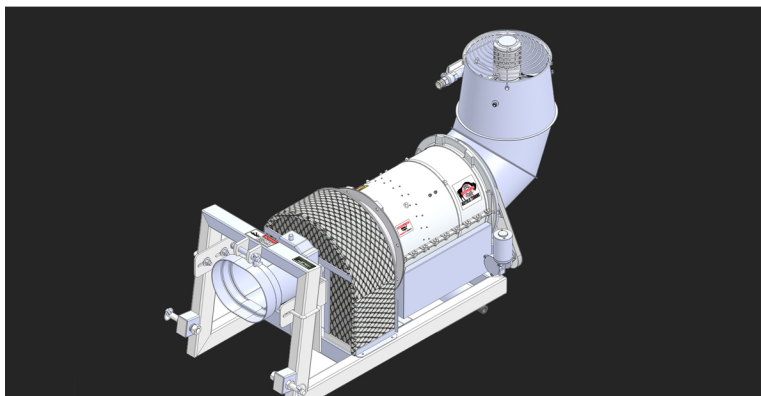

### PTO DUST/ODOR CONTROLLER

- LIGHTWEIGHT
- REQUIRES ONLY STANDARD WATER PRESSURE
- NO EXTRA ENGINE TO SERVICE



# BUFFALO TURBINE



**TALK WITH OUR EXPERTS**

8AM-4:30PM (Mon-Fri) EST

(716) 592-2700

BuffaloTurbine.com

## PTO DUST/ODOR CONTROLLER

### TOP BENEFITS

- Powerful and versatile
- Easy to operate and maintain
- Requires only standard water pressure
- 10 year manufacturer warranty

### TOP FEATURES

- Standard garden hose hookup
- No extra engine to service
- Only 20 hp required at the PTO
- Lightweight (282 lbs. including PTO shaft)
- 360° nozzle control
- Minimal Maintenance

### GENERAL INFO

- Gyrotory atomizing nozzle system
- Hose input: 3/4" utility / garden hose
- Min/Max water volume: 1/3 gallon - 20 gallons per minute at 120 psi
- Min/Max water pressure: 40 psi - 120 psi
- Droplet size: 50 - 200 microns
- Throw distance (neutral wind conditions):  
Vertical-up to 50 ft / Horizontal-up to 125 ft

### Applications

Demolition Sites • Landfills • Wood Recycling  
Scrap Metal Recycling • Aggregate Processing  
Waste Transfer

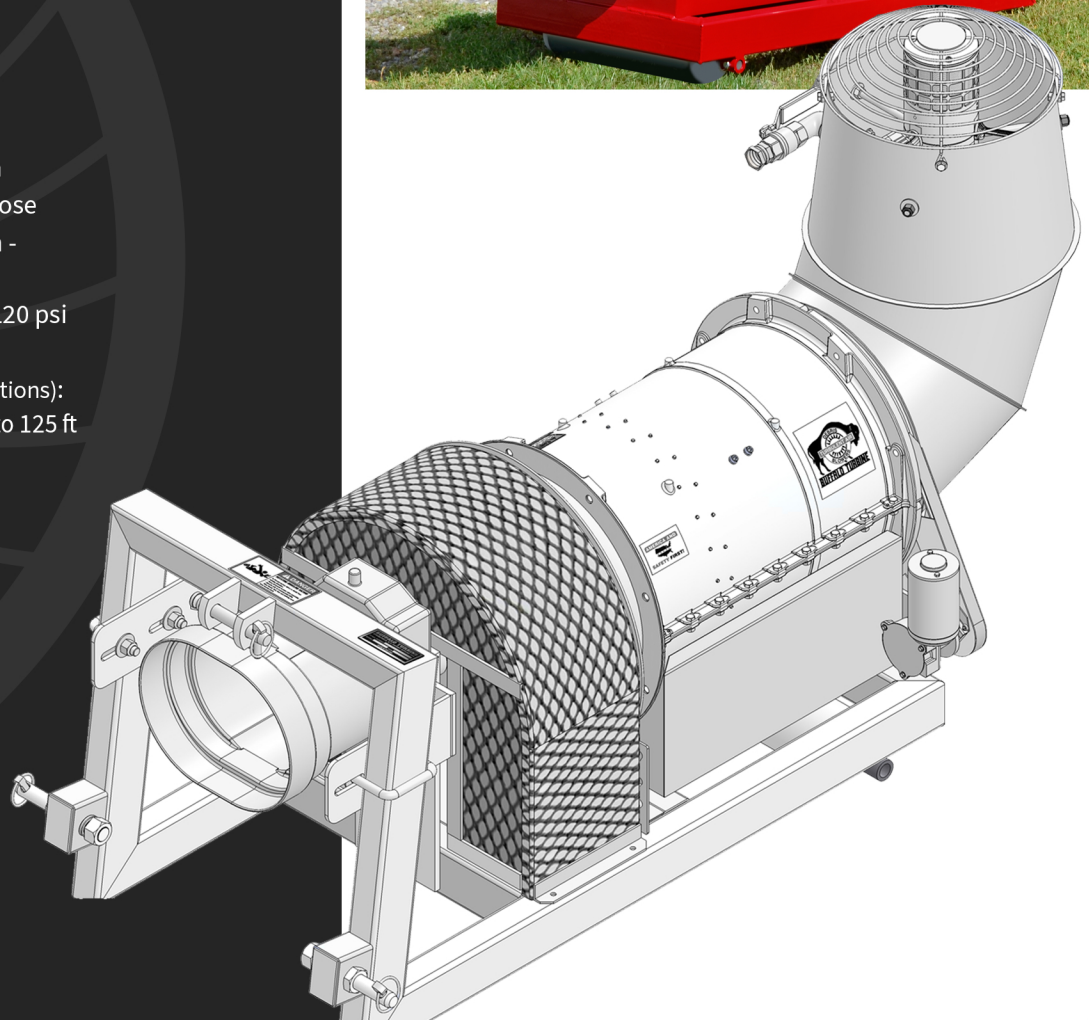

**WARNING:** Cancer & Reproductive Harm - [www.P65Warnings.ca.gov](http://www.P65Warnings.ca.gov)

